

# Yealink



## SIP-T46G IP Phone User Guide

Microsoft<sup>®</sup> Skype for Business<sup>™</sup> Edition

Version 8.21  
May. 2016

# Copyright

**Copyright © 2016 YEALINK(XIAMEN) NETWORK TECHNOLOGY CO., LTD.**

Copyright © 2016 Yealink(Xiamen) Network Technology CO., LTD. All rights reserved. No parts of this publication may be reproduced or transmitted in any form or by any means, electronic or mechanical, photocopying, recording, or otherwise, for any purpose, without the express written permission of Yealink(Xiamen) Network Technology CO., LTD. Under the law, reproducing includes translating into another language or format.

When this publication is made available on media, Yealink(Xiamen) Network Technology CO., LTD. gives its consent to downloading and printing copies of the content provided in this file only for private use but not for redistribution. No parts of this publication may be subject to alteration, modification or commercial use. Yealink(Xiamen) Network Technology CO., LTD. will not be liable for any damages arising from use of an illegally modified or altered publication.

## Warranty

THE SPECIFICATIONS AND INFORMATION REGARDING THE PRODUCTS IN THIS GUIDE ARE SUBJECT TO CHANGE WITHOUT NOTICE. ALL STATEMENTS, INFORMATION, AND RECOMMENDATIONS IN THIS GUIDE ARE BELIEVED TO BE ACCURATE AND PRESENTED WITHOUT WARRANTY OF ANY KIND, EXPRESS OR IMPLIED. USERS MUST TAKE FULL RESPONSIBILITY FOR THEIR APPLICATION OF PRODUCTS.

YEALINK(XIAMEN) NETWORK TECHNOLOGY CO., LTD. MAKES NO WARRANTY OF ANY KIND WITH REGARD TO THIS GUIDE, INCLUDING, BUT NOT LIMITED TO, THE IMPLIED WARRANTIES OF MERCHANTABILITY AND FITNESS FOR A PARTICULAR PURPOSE. Yealink(Xiamen) Network Technology CO., LTD. shall not be liable for errors contained herein nor for incidental or consequential damages in connection with the furnishing, performance, or use of this guide.

## Declaration of Conformity



Hereby, Yealink(Xiamen) Network Technology CO., LTD. declares that this phone is in conformity with the essential requirements and other relevant provisions of the CE, FCC.

You can find the CE and FCC information from the label on the back of the IP phone.

Statements of compliance can be obtained by contacting [support@yealink.com](mailto:support@yealink.com).

## CE Mark Warning

This device is marked with the CE mark in compliance with EC Directives 2014/30/EU and 2014/35/EU.

## Part 15 FCC Rules

Any changes or modifications not expressly approved by the party responsible for compliance could void the user's authority to operate the equipment.

This device is compliant with Part 15 of the FCC Rules. Operation is subject to the following two conditions:

1. This device may not cause harmful interference.
2. This device must accept any interference received, including interference that may cause undesired operation.

## Class B Digital Device or Peripheral

Note: This device is tested and complies with the limits for a Class B digital device, pursuant to Part 15 of the FCC Rules. These limits are designed to provide reasonable protection against harmful interference in a residential installation. This equipment generates, uses, and can radiate radio frequency energy and, if not installed and used in accordance with the instructions, may cause harmful interference to radio communications. However, there is no guarantee that interference will not occur in a particular installation. If this equipment does cause harmful interference to radio or television reception, which can be determined by turning the equipment off and on, the user is encouraged to try to correct the interference by one or more of the following measures:

1. Reorient or relocate the receiving antenna.
2. Increase the separation between the equipment and receiver.
3. Connect the equipment into an outlet on a circuit different from that to which the receiver is connected.
4. Consult the dealer or an experienced radio/TV technician for help.

## WEEE Warning



To avoid the potential effects on the environment and human health as a result of the presence of hazardous substances in electrical and electronic equipment, end users of electrical and electronic equipment should understand the meaning of the crossed-out wheeled bin symbol. Do not dispose of WEEE as unsorted municipal waste and have to collect such WEEE separately.

## Customer Feedback

We are striving to improve our documentation quality and we appreciate your feedback. Email your opinions and comments to [DocsFeedback@yealink.com](mailto:DocsFeedback@yealink.com).

# GNU GPL INFORMATION

Yealink SIP-T46G IP phone firmware contains third-party software under the GNU General Public License (GPL). Yealink uses software under the specific terms of the GPL. Please refer to the GPL for the exact terms and conditions of the license.

The original GPL license, source code of components licensed under GPL and used in Yealink products can be downloaded online:

<http://www.yealink.com/GPLOpenSource.aspx?BaseInfoCatId=293&NewsCatId=293&CatId=293>.





## About This Guide

Yealink SIP-T46G IP phone with Skype for Business firmware enables a new era in unified communications. It is designed to work with Skype for Business 2015. Connecting a Yealink SIP-T46G IP phone to Skype for Business Server allows you to place regular and Voice over Internet Protocol (VoIP) calls, answer calls, forward calls, conduct a Skype for Business conference call, and dial from your Skype for Business contacts list through integration with Microsoft's Active Directory.

This guide provides everything you need to quickly use your new phone. First, verify with your system administrator that the network is prepared for configuring your Yealink SIP-T46G IP phone, and your network is correctly configured. Also be sure to read the Packaging Contents and Regulatory Notices sections in this guide before you set up and use the Yealink SIP-T46G IP phone.

## In This Guide

Topics provided in this guide include:

- Chapter 1 [Overview](#)
- Chapter 2 [Getting Started](#)
- Chapter 3 [Customizing Your Phone](#)
- Chapter 4 [Basic Call Features](#)
- Chapter 5 [Common Area Phone](#)
- Chapter 6 [Better Together over Ethernet](#)
- Chapter 7 [EXP40 Expansion Module](#)
- Chapter 8 [Troubleshooting](#)



# Table of Contents

<b>About This Guide .....</b>	<b>vi</b>
In This Guide .....	vi
<b>Table of Contents.....</b>	<b>viii</b>
<b>Overview .....</b>	<b>1</b>
Hardware Component Instructions.....	1
Icon Instructions.....	3
LED Instructions.....	4
User Interfaces .....	5
Phone User Interface .....	5
Web User Interface.....	7
Documentations .....	9
<b>Getting Started.....</b>	<b>11</b>
Packaging Contents.....	11
Optional Accessories .....	12
Phone Installation.....	14
Phone Initialization .....	17
Sign-in.....	17
User Sign-in.....	19
PIN Sign-in.....	20
Device Pairing for Online .....	21
Sign-out.....	24
Changing Presence Status.....	25
Always Online .....	27
Account Lock.....	28
Idle Screen.....	29
Status Screen.....	31
History Screen .....	31
Directory Screen .....	32
Menu Screen .....	32
Entering Data and Editing Fields .....	32
Phone Status .....	35
Basic Network Settings.....	36

<b>Customizing Your Phone .....</b>	<b>39</b>
General Settings .....	39
Language.....	39
Backlight .....	40
Contrast.....	41
Time & Date .....	42
Administrator Password .....	44
Key as Send.....	45
Phone Lock.....	46
Audio Settings .....	48
Volume .....	48
Ring Tones .....	49
Contact Management.....	50
Skype for Business Directory .....	51
Local Directory .....	56
Placing Calls to Contacts .....	68
Searching for Contacts.....	69
Call History Management .....	71
Headset Use .....	73
Headset Mode Activation/Deactivation .....	73
Headset Prior.....	73
Dual Headset .....	74
Bluetooth .....	75
Enabling the Bluetooth Mode .....	76
Pairing and Connecting the Bluetooth Headset .....	76
Viewing the Bluetooth headset information .....	78
Editing the Bluetooth Device Information .....	79
Disconnecting the Bluetooth Headset.....	80
Deleting the Bluetooth Headset.....	80
Disabling the Bluetooth Mode .....	81
E911.....	82
E911 Location Tip .....	82
Location Notification.....	83
Adding the Location Information .....	85
Viewing the Location Information .....	86
Emergency Call.....	86
Dial-now .....	87
Live Dialpad.....	89
Privacy Mode.....	90
Modifying the Privacy Mode from the Phone.....	91
Modifying the Privacy Mode from the Skype for Business Client .....	91
<b>Basic Call Features .....</b>	<b>93</b>

Placing Calls .....	93
Answering Calls .....	95
Ending Calls .....	96
Redialing Numbers .....	97
Auto Answer .....	97
Call Waiting .....	97
Call Mute.....	99
Call Hold/Resume.....	99
Calendar .....	100
Setting up a Skype Conference in Outlook .....	101
Setting up an Appointment in Outlook .....	101
Setting up a Meeting in Outlook.....	102
Setting up an Event in Outlook.....	103
Using the Calendar .....	104
Call Forward .....	112
Static Forwarding.....	113
Dynamic Forwarding .....	120
Response Groups .....	122
Boss-Admin Feature.....	123
Assigning/Removing Delegates .....	124
Viewing the Bosses/Delegates .....	126
Using the Boss-Admin.....	127
Inbound Private Line .....	134
Call Transfer .....	136
Blind Transfer .....	136
Attended Transfer .....	137
Group Call Pickup .....	138
Skype for Business Conference .....	138
Initiating a Skype Conference Call.....	138
Viewing the Dial-in Number and Conference ID .....	142
Viewing the Conference Participants .....	143
Managing the Conference Participants.....	143
Call Park .....	152
Voice Mail .....	154
Leaving the Voice Mail.....	154
Managing the Voice Mail .....	154
Multicast Paging.....	158
Sending RTP Stream .....	159
Receiving RTP Stream.....	161
Using Multicast Paging.....	162
Branch Office Resiliency.....	164
<b>Common Area Phone .....</b>	<b>167</b>
Signing into a Common Area Phone .....	167

Using a Common Area Phone .....	167
Switching to a Skype for Business Account.....	168
Signing out of a Common Area Phone .....	169
<b>Better Together over Ethernet .....</b>	<b>171</b>
Getting Started with Better Together over Ethernet .....	171
Installing the Yealink Better Together over Ethernet Connector .....	171
Enabling Better Together over Ethernet .....	176
Configuring BToE .....	177
Paired Status.....	177
Pairing your phone with Skype for Business client.....	179
BToE Sign-in.....	181
Setting the IP Phone as Primary Device .....	184
Using Better Together over Ethernet .....	184
<b>EXP40 Expansion Module.....</b>	<b>187</b>
Connecting the EXP40.....	187
EXP40 Hardware Component Instructions .....	189
Assigning Skype for Business Contacts to the EXP40 .....	190
Using the EXP40.....	191
Placing a Call Using the EXP40 .....	191
Initiating a Conference Call Using the EXP40.....	192
Transferring a Call Using the EXP40.....	192
<b>Troubleshooting .....</b>	<b>195</b>
Troubleshooting Solutions .....	195
<b>Regulatory Notices .....</b>	<b>209</b>
Service Agreements .....	209
Limitations of Liability .....	209
Safety Instructions .....	209
<b>Appendix A - Time Zones.....</b>	<b>211</b>
<b>Index.....</b>	<b>213</b>





# Overview

This chapter provides the overview of the SIP-T46G IP phone. Topics include:

- [Hardware Component Instructions](#)
- [Icon Instructions](#)
- [LED Instructions](#)
- [User Interfaces](#)
- [Documentations](#)





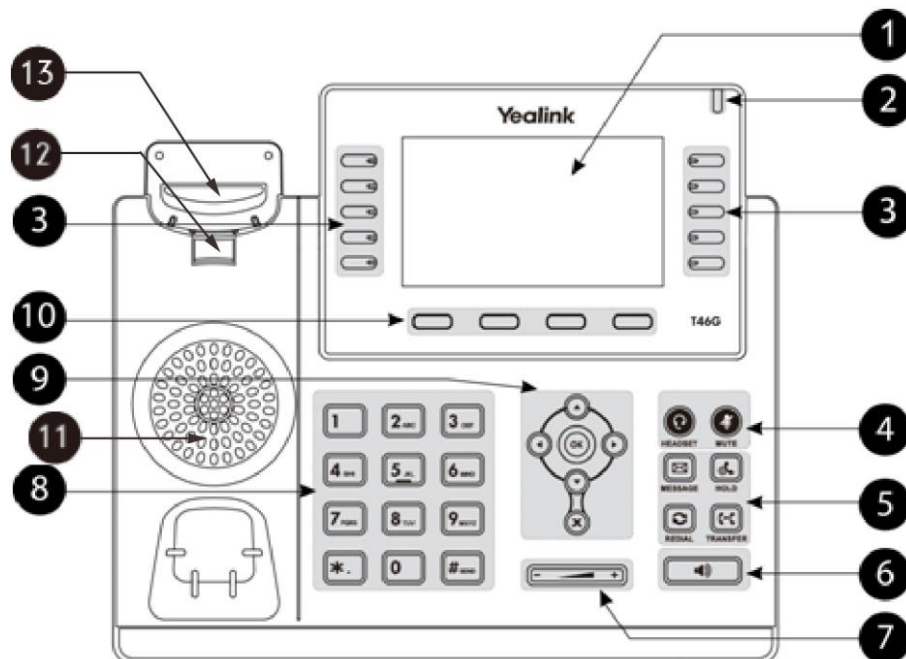

If you require additional information or assistance with your new phone, contact your system administrator.

## Hardware Component Instructions

The main hardware components of the SIP-T46G IP phone are the LCD screen and the keypad.



















Hardware component instructions of the SIP-T46G IP phone are:













	Item	Description
①	LCD Screen	Shows information about calls, messages, soft keys, time, date and other relevant data: <ul style="list-style-type: none"> <li>• Call information—caller ID, call duration</li> <li>• Icons (for example,  )</li> <li>• Missed call text or second incoming caller information</li> <li>• Prompt text (for example, "Saving config file!")</li> <li>• Time and date</li> </ul>
②	Power Indicator LED	Indicates phone power and some feature statuses. <ul style="list-style-type: none"> <li>• Receives an incoming call—Fast flashing</li> <li>• Receives a voice mail—Slow flashing</li> </ul>
③	Line Keys	<ul style="list-style-type: none"> <li>• Enable you to select a phone line</li> <li>• Call a favorite contact quickly</li> <li>• Answer incoming calls</li> <li>• Assign Boss-Admin feature</li> <li>• Assign multicast paging feature</li> </ul>
④	HEADSET Key	Toggles and indicates the headset mode.
	MUTE Key	Toggles and indicates mute feature.
⑤	MESSAGE Key	Accesses voice messages.
	HOLD Key	Places a call on hold or resumes a held call.
	REDIAL Key	Redials a previously dialed number.
	TRANSFER Key	Transfers a call to another party.
⑥	Speakerphone Key	Toggles and indicates the hands-free speakerphone mode.
⑦	Volume Key	Adjusts the volume of the handset, headset, speaker, and ringer.
⑧	Keypad	Provides the digits, letters and special characters in context-sensitive applications.
⑨	   	Scroll through the displayed information.
		Confirms actions or answers incoming calls.
		Cancels actions or rejects incoming calls.
⑩	Soft Keys	Label automatically to identify their context-sensitive features.
⑪	Speaker	Provides hands-free (speakerphone) audio output.
⑫	Hookswitch Tab	Secures the handset in the handset cradle when the IP phone is mounted vertically. For more information on how to adjust the hookswitch tab, refer to <a href="#">Yealink Wall Mount Quick Installation Guide for Yealink IP Phones</a> .

	Item	Description
⑬	Hookswitch	Picking up the handset from the handset cradle, the hookswitch bounces and the phone connects to the line, laying the handset down on the handset cradle, the phone disconnects from the line.

## Icon Instructions

Icons appearing on the LCD screen are described in the following table:

Icons	Description
	Local Favorites
	Call Forward
	Received Calls
	Placed Calls
	Missed Calls
	Forwarded Calls
	Handset mode
	Headset mode
	Hands-free speakerphone mode
	Speakerphone muted
	Voice mail unread
	Voice mail read
<b>AA</b>	Auto Answer
	Call Mute
	Call Hold
	Phone lock
	Calendar reminder
	Location is not set
	Bluetooth

Icons	Description
	Bluetooth headset is both paired and connected
	Organizer
	Presenter
	Attendee
	The participant is muted
	Conference lock
	Available
	Busy
	Do Not Disturb
	Be Right Back/Off Work/Away
	Off Line
	Unknown

## LED Instructions

### Power Indicator LED

LED Status	Description
Solid red	The phone is initializing.
Fast flashing red	The phone is ringing.
Slow flashing red	The phone receives a voice mail.
Off	The phone is powered off. The phone is idle. The phone is busy. The call is placed on hold or is held. The call is muted.

### The first line key LED (configured as a phone line)

LED Status	Description
Solid green	The line is seized. The line is in conversation.
Fast flashing green	The line receives an incoming call.
Slow flashing green	The call is placed on hold.
Off	The line is inactive.

### The fifth line key LED (configured as Boss Admin)

The local boss-admin phone indicates the phone is involved in a boss-admin call, while the monitoring boss-admin phone indicates the phone is not involved in the boss-admin call.

LED Status	Description
Solid green	The line is in conversation.
Solid green (local boss-admin phone)	The call is placed on hold.
Fast flashing green (monitoring boss-admin phone)	
Off	The line receives an incoming call.

#### Note

The above introduces the default power indicator LED status. The status of the power indicator LED is configurable via web user interface. For more information, refer to [Yealink\\_Microsoft\\_Skype\\_for\\_Business\\_Edition\\_IP\\_Phones\\_Administrator\\_Guide](#).

## User Interfaces

Two ways to customize configurations of your SIP-T46G IP phone:

- The user interface on the IP phone.
- The user interface in a web browser on your PC.

The hardware components keypad and LCD screen constitute the phone user interface, which allows the user to execute all call operation tasks and basic configuration changes directly on the phone. In addition, you can use the web user interface to access all configuration settings. In many cases, it is possible to use either the phone user interface and/or the web user interface interchangeably. However, in some cases, it is only possible to use one or the other interface to operate the phone and change settings.

## Phone User Interface

You can customize your phone by pressing **\*\*\*** to access the phone user interface. The **Advanced** option is only accessible to the administrator, and the default administrator password is "admin" (case-sensitive). For more information on customizing your phone with the available options from the phone user interface, refer to [Customizing Your Phone](#) on page 39.

Menus are used to access information and configure the phone.

The figure below shows the phone's menus and submenus.

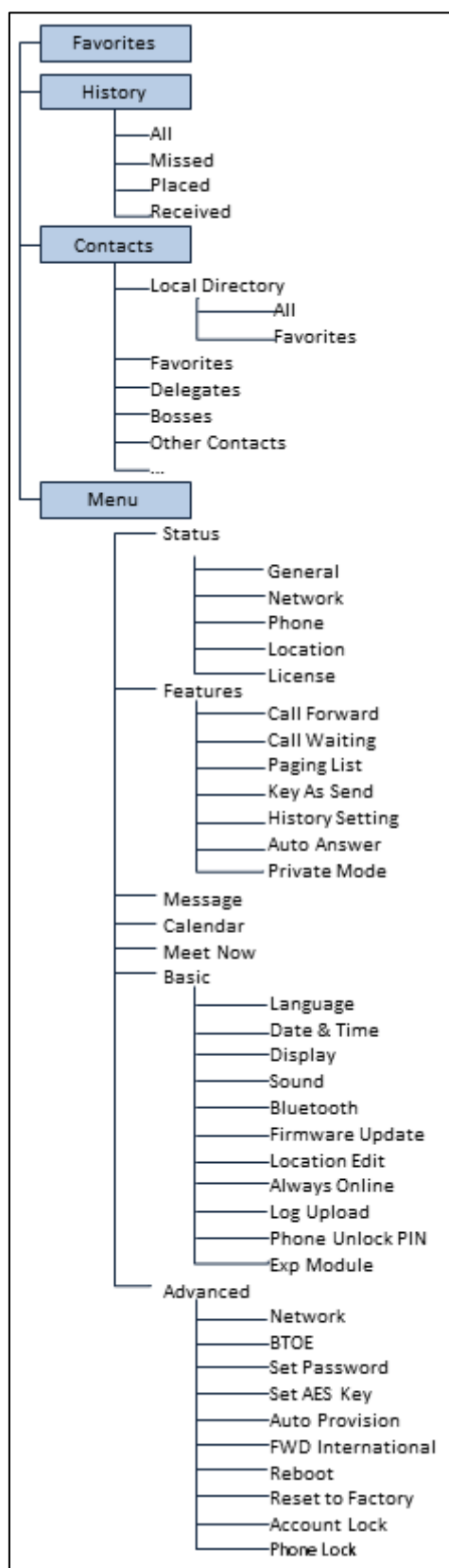

## Web User Interface

In addition to the phone user interface, you can also customize your phone via web user interface. In order to access the web user interface, you need to know the IP address of your new phone. To obtain the IP address, press  on the phone when the phone is idle. Enter the IP address (e.g., http://192.168.0.10 or 192.168.0.10) in the address bar of web browser on your PC. The default administrator user name and password are both "admin" (case-sensitive).

The main options you can use to customize the IP phone via phone user interface and/or via web user interface are listed in the following table:

Options	Phone User Interface	Web User Interface
<b>Status</b>		
--IP Address		
--MAC		
--Firmware	√	√
--Network		
--Phone		
--Location		
--License		
<b>Basic Phone Settings</b>		
--Language	√	
--Time & Date	√	
--Backlight	√	
--Administrator Password	√	√
--Key as Send	√	
--Phone Lock	√	
--BToE	√	
--Account Lock	√	
--Audio Settings		
--Volume	√	×
--Ring Tones	√	√
--Contact Management		
--Skype for Business Directory	√	×
--Local Directory	√	√
--Call History Management	√	√
--Headset Use		
--Headset Mode	√	×
--Headset Prior	×	
--Dual Headset	×	
--Bluetooth	√	√
--Calendar	√	
--Always Online	√	

Options	Phone User Interface	Web User Interface
--Log Upload	√	
--E911 Location Tip	√	
--Dial-now	×	
--Live Dialpad	×	
--Privacy Mode	√	×
<b>Basic Call Features</b>		
--Redialing Numbers	√	
--Auto Answer	√	×
--Call Waiting	√	√
--Call Mute	√	
--Call Hold/Resume	√	
--Call Forward	√	
--Call Transfer	√	×
--Call Park	√	
--Meet Now	√	
--Voice Mail	√	√
--Multicast Paging	√	
<b>Skype for Business Account</b>		
--Pin Sign in		
--Extension	√	
--Pin	√	
--User Sign in		
--Address	√	√
--UserName	√	
--Password	√	
--Device Pairing for Online	√	
--Select site	√	×

**Note**

The table above lists most of the feature options. Please refer to the relevant sections for more information.



## Documentations

The following table shows documentations available for the SIP-T46G IP phone.

Name	Contents	Where found	Language
Quick Start Guide	Basic setup and call features of the phone	In the package/ On the website	English/Chinese
User Guide	Phone/Web user interface settings Basic call features and BToE (Better Together over Ethernet) feature	On the website	English/Chinese

**Note**

You can also download the latest documentations online:

[http://www.yealink.com/solution\\_info.aspx?ProductsCatelD=1248&cateid=1248&BaseInfoCatelD=1328&Cate\\_Id=1248&parentcateid=1328](http://www.yealink.com/solution_info.aspx?ProductsCatelD=1248&cateid=1248&BaseInfoCatelD=1328&Cate_Id=1248&parentcateid=1328).



# Getting Started

This chapter provides the following basic installation instructions and information for obtaining the best performance with the SIP-T46G IP phone. Topics include:

- [Packaging Contents](#)
- [Phone Installation](#)
- [Phone Initialization](#)
- [Sign-in](#)
- [Changing Presence Status](#)
- [Account Lock](#)
- [Idle Screen](#)
- [Entering Data and Editing Fields](#)
- [Phone Status](#)
- [Basic Network Settings](#)

If you require additional information or assistance with your new phone, contact your system administrator.

## Packaging Contents

The following components are included in your SIP-T46G IP phone package:

- **SIP-T46G IP Phone**

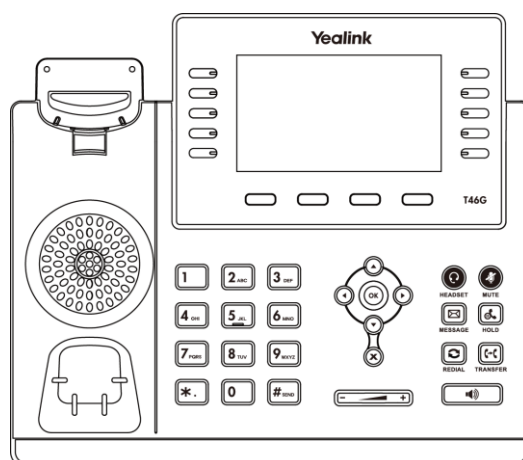

- **Phone Stand**

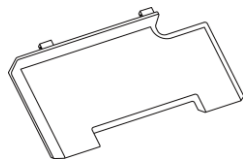

- **Handset & Handset Cord**

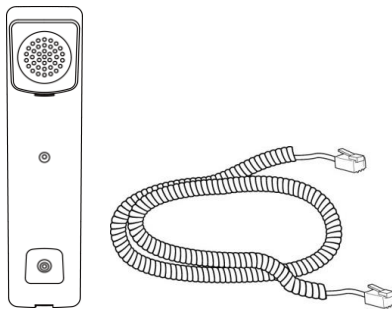

- **Ethernet Cable**

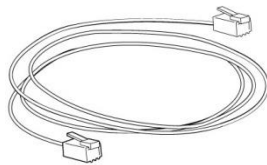

- **Quick Start Guide**

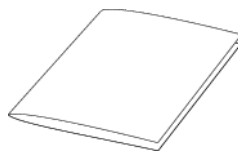

Check the list before installation. If you find anything missing, contact your system administrator.

## Optional Accessories

- **Power Adapter**

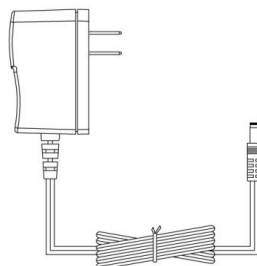

- **Wall Mount Bracket**

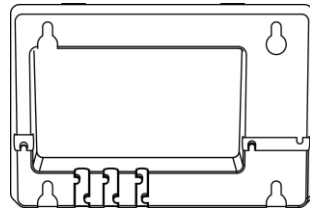

- **Headset**



- **Wireless Headset Adapter EHS36**



- **Bluetooth USB Dongle BT40**



- **EXP40 Expansion Module**

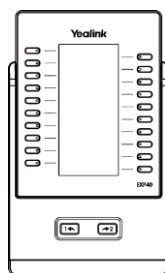

**Note** We recommend that you use the accessories provided or approved by Yealink. The use of unapproved third-party accessories may result in reduced performance.

## Phone Installation

If your phone is already installed, proceed to [Phone Initialization](#) on page 14.

This section introduces how to install the phone:

- 1) Attach the stand or the optional wall mount bracket
- 2) Connect the handset and optional headset
- 3) Connect the network and power

- 1) **Attach the stand or the optional wall mount bracket**

### Desk Mount Method

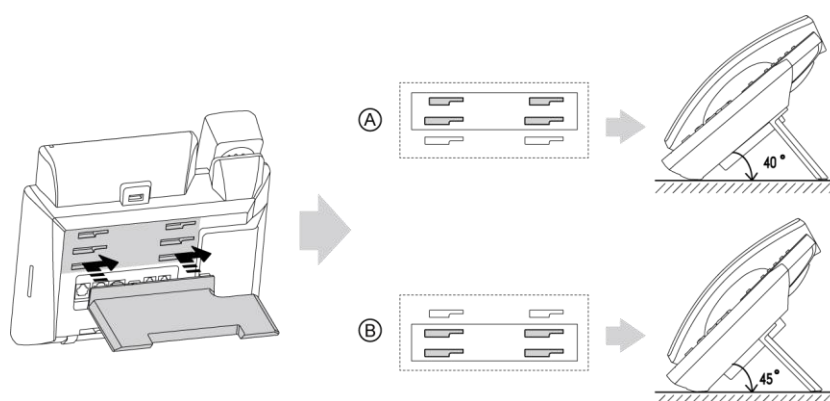

### Wall Mount Method (Optional)

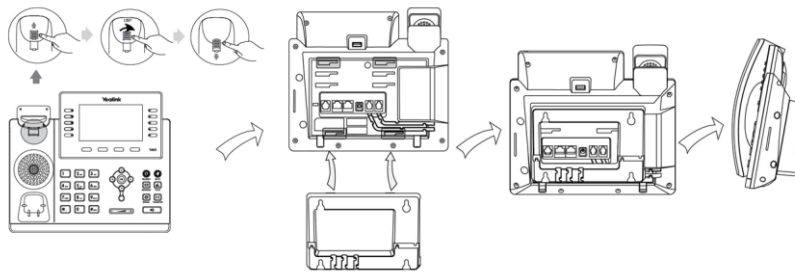

#### Note

The hookswitch tab has a lip which allows the handset to stay on-hook when the IP phone is mounted vertically.

For more information on how to attach the wall mount bracket, refer to [Yealink Wall Mount Quick Installation Guide for Yealink IP Phones](#).

### 2) Connect the handset and optional headset

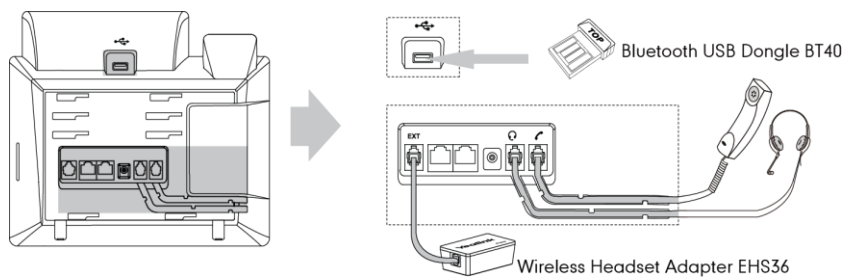

#### Note

The EXT port can also be used to connect an expansion module EXP40.

For more information on how to use EHS36 or Bluetooth USB Dongle BT40, refer to [Yealink EHS36 User Guide](#) or [Yealink Bluetooth USB Dongle BT40 User Guide](#).

### 3) Connect the network and power

You have two options for power and network connections. Your system administrator will advise you which one to use.

- AC power (Optional)
- Power over Ethernet (PoE)

## AC Power (Optional)

### To connect the AC power:

1. Connect the DC plug on the power adapter to the DC5V port on the phone and connect the other end of the power adapter into an electrical power outlet.
2. Connect the included or a standard Ethernet cable between the Internet port on the phone and the one on the wall or the switch/hub device port.

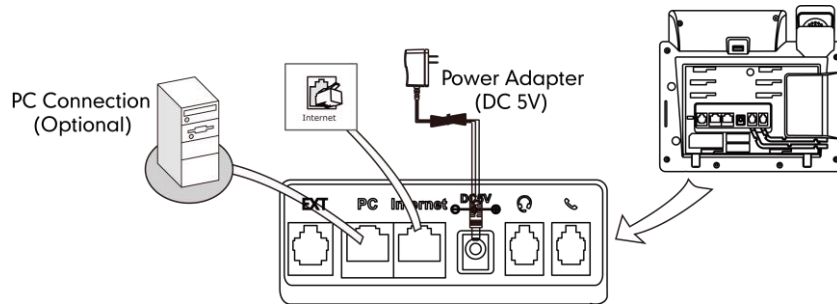

### Note

The IP phone should be used with Yealink original power adapter (5V/2A) only. The use of the third-party power adapter may cause the damage to the phone.

## Power over Ethernet

With the included or a regular Ethernet cable, the SIP-T46G IP phone can be powered from a PoE-compliant switch or hub.

### To connect the PoE:

1. Connect the Ethernet cable between the Internet port on the phone and an available port on the in-line power switch/hub.

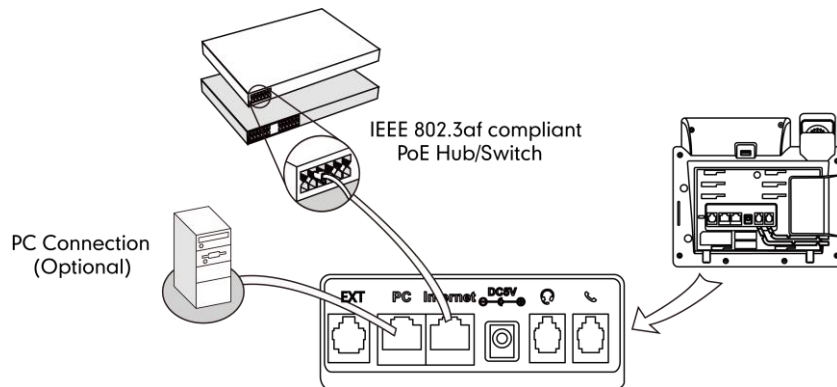

### Note

If in-line power is provided, you don't need to connect the phone to the power adapter. Make sure the switch/hub is PoE-compliant.

The phone can also share the network with another network device such as a PC (personal computer). It is an optional connection.

**Important!** Do not remove power to the phone while it is updating firmware and configurations.



## Phone Initialization

After your phone is powered on, the system boots up and performs the following steps:

### Automatic Phone Initialization

The phone finishes the initialization by loading the saved configuration. The LCD screen displays "Welcome Initializing...Please wait" during the initialization.

### DHCP (Dynamic Host Configuration Protocol)

The phone attempts to contact a DHCP server in your network to obtain valid IPv4 network settings (e.g., IP address, subnet mask, default gateway address and DNS address) by default.

After the phone finishes the initialization, the sign-in screen appears on the LCD screen.

#### Note

If your network does not use DHCP, proceed to [Basic Network Settings](#) on page 36.

## Sign-in

After the initialization, the idle screen appears. The screen will be shown as below:



You can press **Menu** soft key to enter the menu screen before signing into the Skype for Business Server. The menu screen is shown as below:

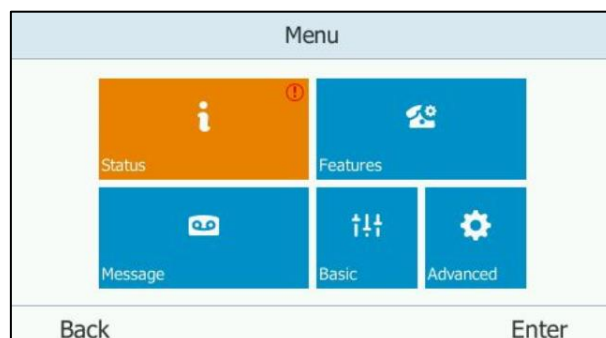

From the menu screen, you can view phone status, message, configure call features or

phone settings.

You can press the **Sign in** soft key to enter the sign-in screen. The sign-in screen is shown as below:

Skype for Business users are authenticated against Microsoft Active Directory Domain Service. The following four sign-in methods are available:

- **User Sign in:** This method uses the user's credentials (sign-in address, user name, and password) to sign into Skype for Business Server. This sign-in method is applicable to Onprem account and Online account.
- **PIN Sign in:** This method uses the user's phone number (or extension) and personal identification number (PIN) to sign into Skype for Business Server. This sign-in method is only applicable to Onprem account.
- **Device Pairing for Online:** This method uses the user's Online account and pairing code to sign into Skype for Business Server. This sign-in method is only applicable to Online account.
- **BToE Sign-in:** This method uses the Skype for Business client to sign into Skype for Business Server. You need to download and install the Yealink BToE Connector application on your PC first, and then pair your phone to Skype for Business client. As a result, you will sign into the Skype for Business client and phone using same account. This sign-in method is applicable to Onprem account and Online account. For more information, refer to [Better Together over Ethernet](#) on page 171.

If the Skype for Business Server is configured to forcibly lock the phone. You need to configure an unlock PIN at the initial sign-in. For more information, refer to [Phone Lock](#) on page 46.

**Note**

If the phone reboots after successful login, the login credentials from the previous Sign-In will be cached. User can sign in successfully without reentering the credentials.

## User Sign-in

To sign into the Skype for Business Server using User Sign in method via phone user interface:

1. Press the **Sign in** soft key.
2. Press ◀ or ▶, or the **Switch** soft key to select **User Sign in**.
3. Enter your Skype for Business user's sign-in address (e.g., 2216@yealinkuc.com) in the **Address** field.
4. Enter your Skype for Business user name (e.g., 2216@yealinkuc.com) in the **UserName** field.
5. Enter the sign-in password in the **Password** field.

6. Press ◀ , ▶ or the **Switch** soft key to select the desired value from the **Remember Password** field.

If it is on, the user name and password will be filled automatically when you enter the sign-in address next time.

7. Press the **Sign in** soft key.

To sign into the Skype for Business Server using User Sign in method via web user interface:

1. Click on **Account->Register**.
2. Select **User Sign in** from the pull-down list of **Mode**.
3. Enter your Skype for Business user's sign-in address (e.g., 2216@yealinkuc.com) in the **Login address** field.
4. Enter your Skype for Business user name (e.g., 2216@yealinkuc.com) in the **Register Name** field.

5. Enter the sign-in password in the **Password** field.

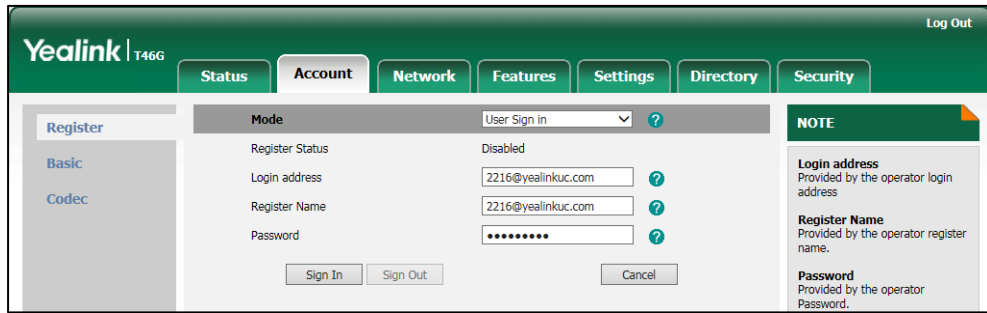

6. Click **Sign In** to accept the change.

## PIN Sign-in

To sign into Skype for Business Server using PIN Sign in method via phone user interface:

1. Press the **Sign in** soft key.
2. Press  $\leftarrow$  or  $\rightarrow$  , or the **Switch** soft key to select **PIN Sign in**.
3. Enter your phone number or extension (e.g., 2216) in the **extension** field.
4. Enter your Pin in the **PIN** field.

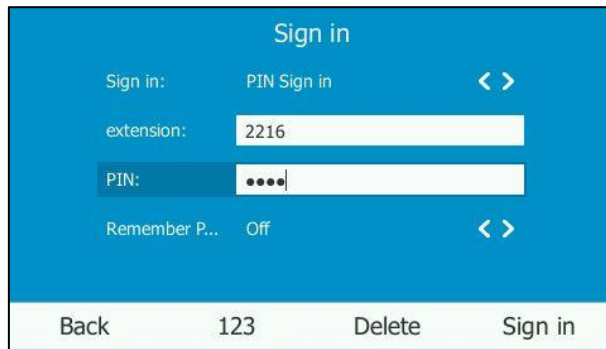

5. Press  $\leftarrow$  ,  $\rightarrow$  or the **Switch** soft key to select the desired value from the **Remember Password** filed.

If it is on, the PIN will be filled automatically when you enter the phone number or extension next time.

6. Press the **Sign in** soft key.

To sign into the Skype for Business Server using PIN Sign in method via web user interface:

1. Click on **Account->Register**.
2. Select **Pin Sign in** from the pull-down list of **Mode**.
3. Enter your Skype for Business user's phone number or extension (e.g., 2216) in the **Extension** field.

- Enter your personal identification number (e.g., user2216) in the **Pin** field.

- Click **Sign In** to accept the change.

## Device Pairing for Online

Device pairing for online is used to establish the connection between your phone and PC, so that you can sign into phone by web browser. This sign-in method is only applicable to Online account.

To configure Device Pairing for Online method via web user interface:

- Click on **Features->General Information**.
- Select the desired value from the pull-down list of **Device Pairing for Online**.
  - If it is enabled, you can sign into the Skype for Business Server using Device Pairing for Online method.
  - If it is disabled, you cannot sign into the Skype for Business Server using Device Pairing for Online method.

- Click **Confirm** to accept the change.

To sign into Skype for Business Server using Device Pairing for Online method via phone user interface:

1. Press the **Sign in** soft key.



2. Press ◀ , ▶ or the **Switch** soft key to select **Device Pairing for Online**.
3. Press ◀ , ▶ or the **Switch** soft key to select the corresponding country from the **Select site** field.
4. Press the **Sign in** soft key.

The screen will show the pairing code and URL.

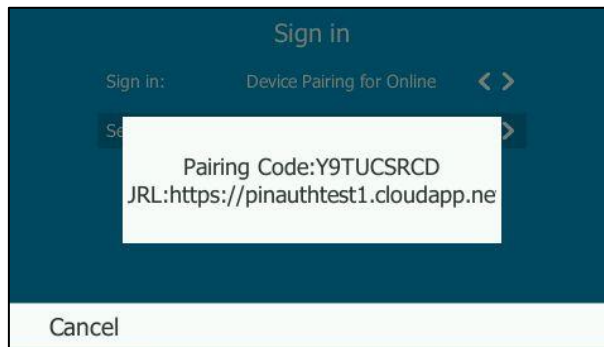

5. Enter the URL (e.g., <https://pinauthtest1.cloudapp.net>) in the address bar of the web browser on your PC, and then press **Enter**.
6. Enter your email address (e.g., [yealink1@lyosbpsmds.ccsctp.net](mailto:yealink1@lyosbpsmds.ccsctp.net)) in the **Email address** field.

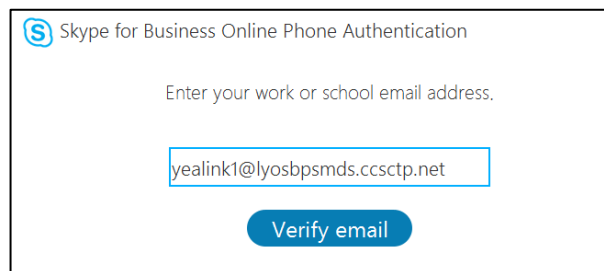

7. Click **Verify email** to check the validity of the email address.

The sign-in screen will appear if the email address is valid.

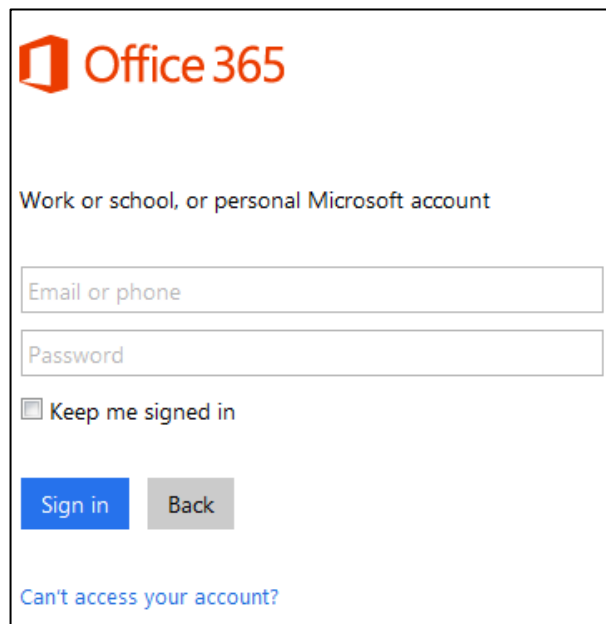

The image shows the Office 365 sign-in screen. At the top left is the Office 365 logo. Below it, the text reads "Work or school, or personal Microsoft account". There are two input fields: "Email or phone" and "Password". Below the "Password" field is a checkbox labeled "Keep me signed in". At the bottom left, there is a blue "Sign in" button and a grey "Back" button. At the bottom center, there is a blue link that says "Can't access your account?".

8. Enter your Online account and password.
9. (Optional) Check the **Keep me signed in** checkbox, so that you don't need to enter a password next time.
10. Click **Sign in**.
11. Enter the pairing code (e.g., Y9TUCSRCD) in the **Code** field.

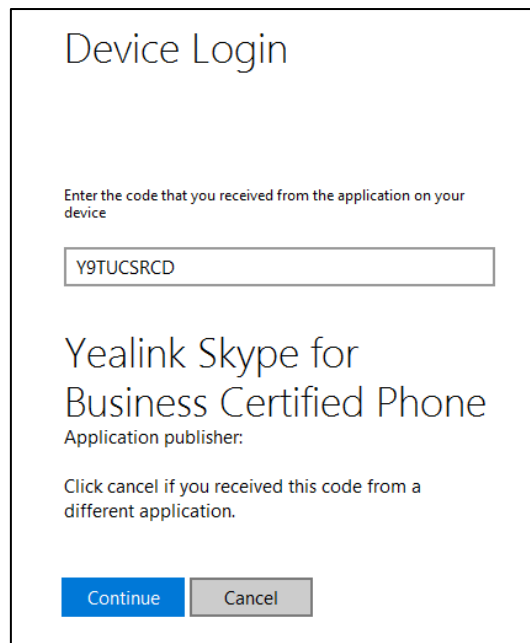

The image shows the "Device Login" screen. At the top, it says "Device Login". Below that, it says "Enter the code that you received from the application on your device". There is an input field containing the code "Y9TUCSRCD". Below the input field, it says "Yealink Skype for Business Certified Phone" and "Application publisher:". At the bottom, it says "Click cancel if you received this code from a different application." and there are two buttons: a blue "Continue" button and a grey "Cancel" button.

12. Click **Continue**.

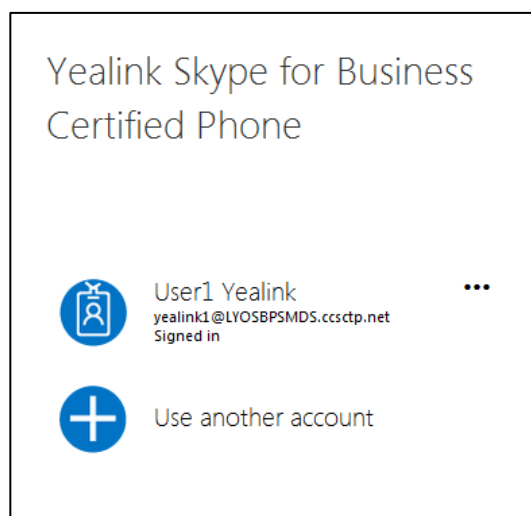

13. Click the account to sign in.

If you click **Use another account**, enter another Online account and password, and then click **Sign in**.

The phone will sign into the Skype for Business Server automatically.

## Sign-out

**To sign out of Skype for Business Server:**

1. Press **i** to enter the account status screen.
2. Press **▲** or **▼** to select **Sign Out**.



The phone signs out of Skype for Business server.

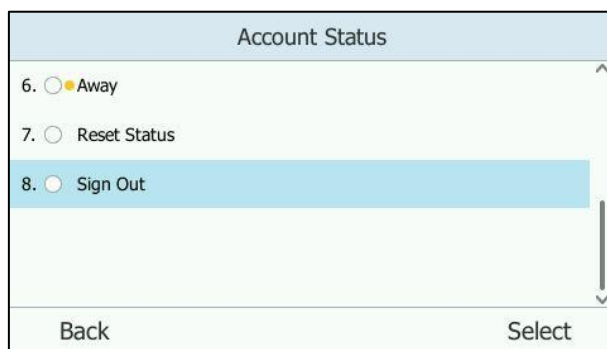

After you sign out of Skype for Business, the account-related features (calling, viewing Skype for Business contacts, calendar, etc.) are not available. However, you can still use other phone features.





Signing out via web user interface at the path: **Account->Register->Sign Out**.

## Changing Presence Status

After signing in successfully, the first line key displays your account and presence status by default.



User's presence information is constantly synchronized with the Skype for Business Server based on a variety of factors. However, you can change your presence information manually on the phone. For example, when you are busy with urgencies, you can change your status to DND to avoid being disturbed.

The following table lists the status that the contact can change on the phone:

Icon	Status	Description
	Available	The contact is online and available to contact.
	Busy	The contact is available but engaged in another activity. Those activities include: <ul style="list-style-type: none"> <li>In a call</li> <li>In a conference</li> </ul>
	DND	If the contact doesn't want to be disturbed and DND is activated, callers will hear a tone indicating that the contact's phone is busy. The incoming call will be forwarded to contact's voice mail directly. The contact can receive calls from the work group only.
	Be Right Back	The contact is engaged in another activity and will return shortly.
	Off Work	The contact is not working and not available

Icon	Status	Description
		to contact.
	Away	<p>The contact is probably not available. This status is displayed for the following reasons:</p> <ul style="list-style-type: none"> <li>• The contact's phone has been idle for more than the idle time period setting—10 minutes by default.</li> <li>• The contact's Microsoft Office Outlook calendar indicates that the contact is out of the office.</li> <li>• The contact is temporarily unavailable. As soon as activity is detected on the contact's phone, Microsoft Skype for Business Server automatically resets the presence status to Available.</li> </ul>

**To change your presence status:**

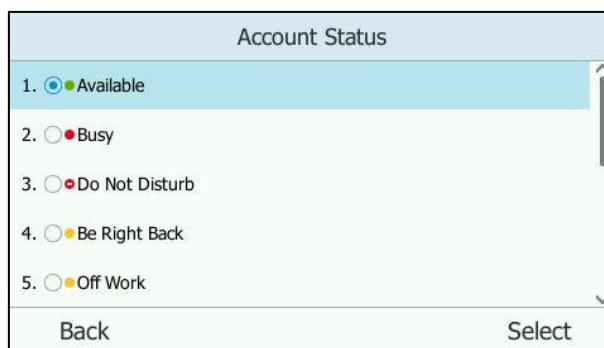

1. Press .
2. Press  or  to highlight the desired status.



3. Press the **Select** soft key to accept the change.

The presence status will be changed on the phone and be synchronized to the Skype for Business Server.

To reset your presence status to the default:

1. Press .
2. Press  or  to highlight **Reset Status**.

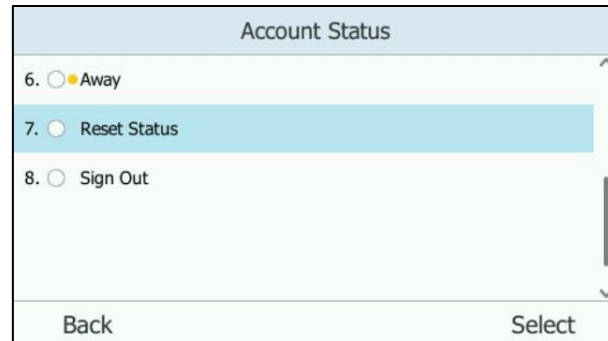

3. Press the **Select** soft key to accept the change or the **Back** soft key to cancel.  
Your status will be reset to "Available".



## Always Online

Always online feature can maintain current status of the phone until you manually change status. For example, the current status of the phone is available, if the always online feature is enabled, then the phone status will stay available until you manually change it. You can configure this feature via phone user interface or web user interface.

To enable the always online via phone user interface:

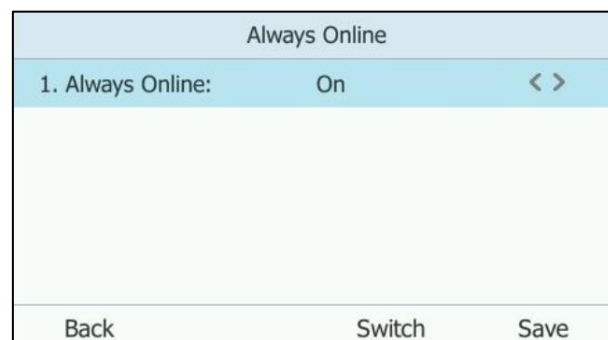
1. Press **...** -> **Basic**-> **Always Online**.



2. Press  or , or the **Switch** soft key to select **On** from the **Always Online** field.
3. Press the **Save** soft key to accept the change or the **Back** soft key to cancel.

Always online is configurable via web user interface at the path

**Account->Basic->Always On Line.**

### Note

If your phone status is DND before dialing an emergency number, then the phone status will be changed to available after the emergency call even if always online feature is enabled. For more information on emergency call, refer to [Emergency Call](#) on page 86.

## Account Lock

You can lock your account to prevent your account being signed in or signed out randomly. If account lock feature is enabled, users are prompted for administrator password to sign in or sign out.

Account lock feature is disabled by default. You can configure it via phone user interface or web user interface.

**To configure the account lock feature via phone user interface:**

1. Press **...** -> **Advanced** (default password: admin) -> **Account Lock**.
2. Press **◀** or **▶**, or the **Switch** soft key to select **On** from the **Account Lock** field.

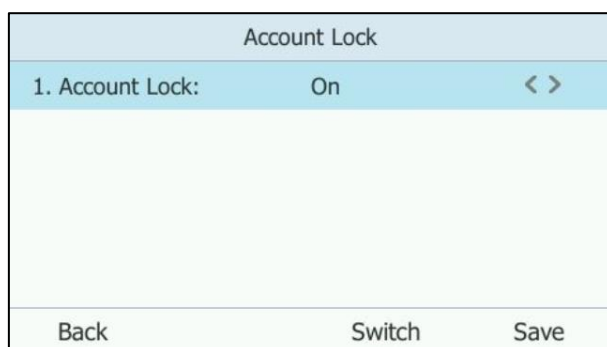

3. Press the **Save** soft key to accept the change or the **Back** soft key to cancel.

Account lock is configurable via web user interface at the path **Account->Basic->Account Lock**.

**To sign out when account lock is enabled via phone user interface:**

1. Press **i** to enter the account status screen.
2. Press **▲** or **▼** to select **Sign Out**.

The screen will be shown as below:

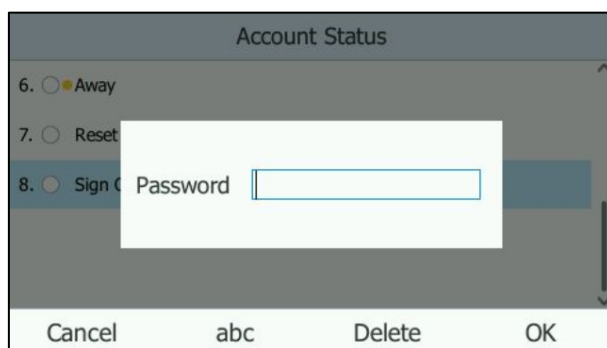

3. Enter the administrator password.
4. Press the **OK** soft key to sign out.

To sign in when account lock is enabled via phone user interface:

1. Press the **Sign in** soft key.
2. Press ◀ or ▶ to select the desired sign-in method.
3. Enter the authentication information in the corresponding field respectively.
4. Press the **Sign in** soft key.

The screen will be shown as below:

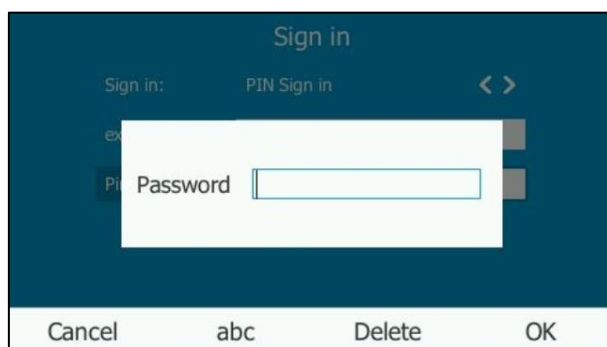





5. Enter the administrator password.
6. Press the **OK** soft key.
  - If phone lock feature is enabled, you will enter the unlock PIN settings screen.
  - If phone lock feature is disabled, you will sign in successfully.

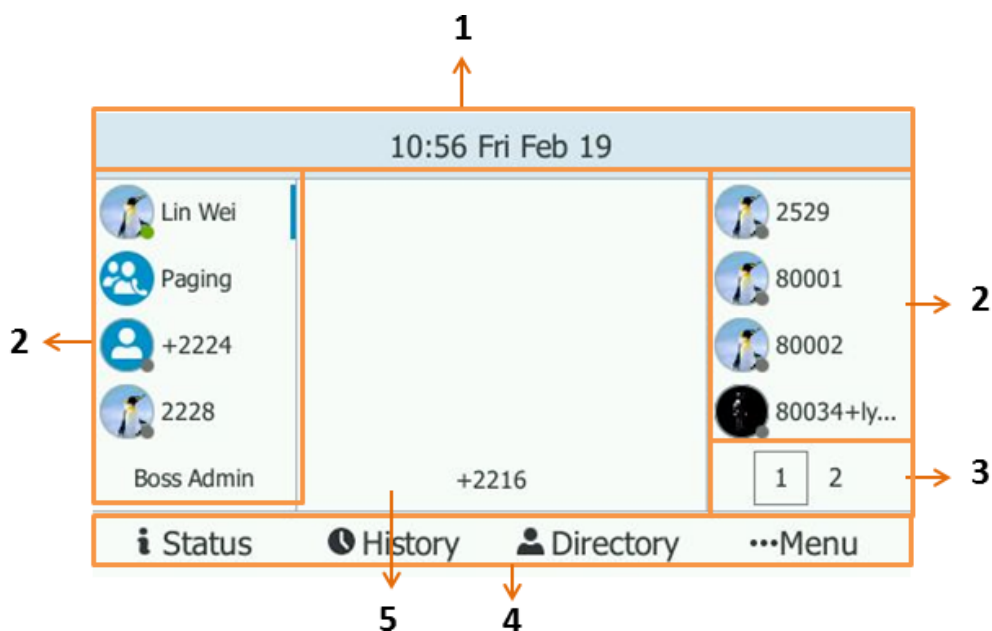

For more information on phone lock, refer to [Phone Lock](#) on page 46.

## Idle Screen

If the phone has successfully started up, and a Skype for Business user signs into Skype for Business Server on the phone, the screen will be shown as below:



No.	Name	Description
1	Status Bar	Shows time and date and the feature status. For more information, refer to <a href="#">Icon Instructions</a> on page 3.
2	Line Key Labels	<ul style="list-style-type: none"> <li>• Show default account.</li> <li>• Show local favorites and Skype for Business favorites. For more information, refer to <a href="#">Contact Management</a> on page 50.</li> <li>• Show the <b>Boss Admin</b> line key. For more information, refer to <a href="#">Boss-Admin Feature</a> on page 123.</li> <li>• Show the <b>Paging</b> line key. For more information, refer to <a href="#">Multicast Paging</a> on page 158.</li> </ul>
3	Page Icons	Shows three page icons. You can press the tenth line key to turn the page.
4	Shortcut Keys	<p>Press  to enter the <b>Status</b> screen and change your presence information.</p> <p>Press  to enter the <b>History</b> screen and view call history.</p> <p>Press  to enter the <b>Contacts</b> screen and view contacts.</p> <p>Press <b>...</b> to enter the <b>Menu</b> screen.</p>
5	Main Window	Shows the phone account and the static forward ways. The phone account is displayed in the bottom-middle of the LCD screen.

When the phone misses calls, a number icon (indicating the number of missed calls) will appear on . If you press  (indicating 1 missed call), the number icon will disappear.

When the phone receives voice mails, a number icon (indicating the number of the voice mails you haven't retrieved) will appear on **...**. If you press **...**, the number icon will disappear.

#### Note

If the phone is in the History screen when the phone missed calls, the  will not appear a number icon.

If the phone is in the Menu screen when the phone receives voice mails, the **...** will not appear a number icon.

## Status Screen

Press  to enter the Status screen. You can change your account status manually.

For more information, refer to [Changing Presence Status](#) on page 25.

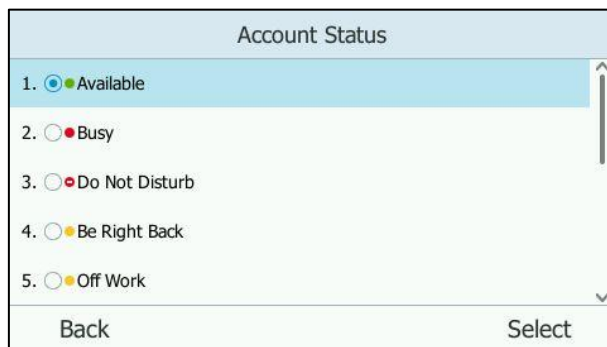

## History Screen

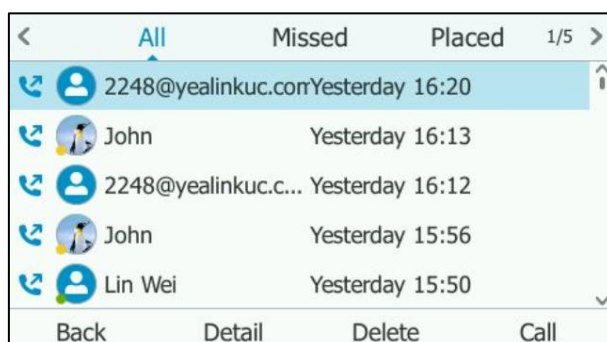

Press  to enter the History screen. You can view **All**, **Missed**, **Placed**, **Received** and **Forwarded** lists.

Each call history list supports up to 100 entries. You can view call history, place a call, add a contact or delete an entry from the call history list.



For more information, refer to [Call History Management](#) on page 71.

## Directory Screen

Press  to enter the Directory screen. The directory window displays the groups and the number of members. You can press  ,  to select the desired group.



## Menu Screen

Press  to enter the Menu screen.

The menu screen consists of seven menu items: Status, Features, Message, Calendar, Meet Now, Basic and Advanced.

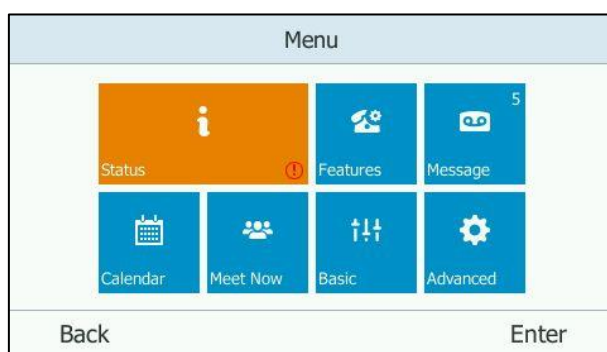













## Entering Data and Editing Fields

You can enter data and edit fields using the phone keypad.

Keypad on the phone provides different characters when using the **2aB**, **abc**, **Abc**, **ABC** or **123** input mode. You can change the following input modes to enter data and edit fields on your phone. When your phone keypad matches the input mode, you can press the keypad repeatedly to view the character (or numbers) options and stop to select. When the character (or numbers) you want to enter displays in the field, wait one second, and enter the next character (or numbers).















The following table lists the input modes and character (or numbers) options for the keypad:

Input Mode Keypad	2aB	abc	Abc	ABC	123
	1				1
	2abcABC	abc2äæå àáâäç	abc2äæå àáâäç	ABC2ÄÆÅ ÀÁÂÃÇ	2
	3defDEF	def3èéêë ø	def3èéêë ø	DEF3ÈÉÊË Ð	3
	4ghiGHI	ghi4ïîï	ghi4ïîï	GHI4ÌÍÏ	4
	5jklJKL	jkl5£	jkl5£	JKL5£	5
	6mnoMN O	mno6öøð óôõñ	mno6öøð óôõñ	MNO6ÖØ ÒÓÔÕÑ	6
	7pqrsPQR S	pqrs7ß	pqrs7ß	PQRS7ß	7
	8tuvTUV	tuv8ùúû	tuv8ùúû	TUV8ÙÚÛ Ü	8
	9wxyzWX YZ	wxyz9ýþ	wxyz9ýþ	WXYZ9ÝÞ	9
	0	space	space	space	0
	*,?!-()@/: _ ; + & % = < > £ \$ ¥ € [] {} ~ ^ ¡ ¢ § # "	*,?!-()@/: _ ; + & % = < > £ \$ ¥ € [] {} ~ ^ ¡ ¢ § # "	*,?!-()@/: _ ; + & % = < > £ \$ ¥ € [] {} ~ ^ ¡ ¢ § # "	*,?!-()@/: _ ; + & % = < > £ \$ ¥ € [] {} ~ ^ ¡ ¢ § # "	*,!/@
	#	#	#	#	#

To enter or edit data:

If you want to	Then you can
Enter only digits (1),	Press a keypad key one or more times

If you want to	Then you can
<p>uppercase (A) characters, lowercase (a) characters, or alphanumeric (2aB) characters.</p>	<p>(depending what input mode you're in) to enter the characters that is displayed on the keypad key.</p> <p>You can press the <b>abc</b> soft key one or more times to switch among uppercase (<b>ABC</b> soft key), numeric (<b>123</b> soft key), alphanumeric (<b>2aB</b> soft key), uppercase and lowercase (<b>Abc</b> soft key) and lowercase (<b>abc</b> soft key) input modes.</p> <p>For example, if the input mode is <b>ABC</b>:</p> <ul style="list-style-type: none"> <li>- To enter "A", press  once.</li> <li>- To enter "B", press  twice quickly.</li> <li>- To enter "C", press  three times quickly.</li> <li>- To enter "2ÄËÄÄÄÄÄÇ", press  more than three times quickly.</li> </ul> <p><b>Note:</b> When you are in the uppercase (<b>ABC</b> soft key), uppercase and lowercase (<b>Abc</b> soft key) or lowercase (<b>abc</b> soft key) input mode,  is not available.</p>
<p>Enter special characters.</p>	<p>Press the keypad key  or  , or long press  .</p> <p><b>For  Key:</b></p> <ul style="list-style-type: none"> <li>- If it is in the uppercase (<b>ABC</b> soft key), uppercase and lowercase (<b>Abc</b> soft key) or lowercase (<b>abc</b> soft key) input mode, it will provide the space character.</li> <li>- If it is in the numeric (<b>123</b> soft key) or alphanumeric (<b>2aB</b> soft key) input mode, it will only provide the digit 0.</li> <li>- Long press  on the pre-dialing screen will provide the special character "+".</li> </ul> <p><b>For  key:</b></p> <ul style="list-style-type: none"> <li>- It only provides the pound character "#".</li> </ul> <p><b>For  key:</b></p> <ul style="list-style-type: none"> <li>- If it is in the uppercase (<b>ABC</b> soft key), lowercase (<b>abc</b> soft key), uppercase and lowercase (<b>Abc</b> soft key) or alphanumeric (<b>2aB</b> soft key) input mode, it will provide</li> </ul>

If you want to	Then you can
	the following special characters: *.,?!\(-)@/;+&%=<>£\$¥€[]{}~^`¡¢\$#" . <ul style="list-style-type: none"> <li>- If it is in the numeric (<b>123</b> soft key) input mode, it will provide the following special characters: .*/@[].</li> </ul>
Delete text you entered.	Press ◀ or ▶ to position the cursor to the right of the text you want to delete, and then press the <b>Delete</b> soft key to delete one character at a time.

## Phone Status

You can view phone status via phone user interface or web user interface.

Available information of phone status includes:

- General information (IP address, MAC address and firmware version)
- Network status (e.g., IPv4 status, IP mode and MAC address)
- Phone status (e.g., product name, hardware, firmware version, product ID MAC address and device certificate status)
- Location information (location is set to assist emergency responder)
- License (device license status)

**To view the phone status via phone user interface:**

1. Press **\*\*\*->Status**.

Status	
1. General	
2. Network	
3. Phone	
4. Location	
5. License	
Back	Enter

2. Press ▲ or ▼ to scroll through the list.
3. Press the **Enter** soft key.

**To view the phone status via web user interface:**

1. Open the web browser on your PC.
2. Enter the IP address in the browser's address bar, and then press the **Enter** key.

3. Enter the user name (admin) and password (admin) in the login page.

4. Click **Confirm** to login.

The phone status is displayed on the first page of the web user interface.

Section	Item	Value
Version	Firmware Version	28.8.0.21
	Hardware Version	28.0.0.128.0.0.0
Network	Internet Port	IPv4
IPv4	WAN Port Type	DHCP
	WAN IP Address	10.2.20.69
	Subnet Mask	255.255.255.0

## Basic Network Settings

If your phone cannot contact a DHCP server for any reason, you need to configure network settings manually. The IP phone can support either or both IPv4 and IPv6 addresses.

To configure the IP mode via phone user interface:

1. Press **...** -> **Advanced** (default password: admin) -> **Network**-> **WAN Port**.
2. Press **←** or **→**, or the **Switch** soft key to select **IPv4**, **IPv6** or **IPv4 & IPv6** from the **IP Mode** field.

3. Press the **Save** soft key to accept the change or the **Back** soft key to cancel.

You can configure a static IPv4 address for the IP phone, make sure that the IP mode is configured as **IPv4** or **IPv4 & IPv6**.

**To configure a static IPv4 address via phone user interface:**

1. Press **...** -> **Advanced** (default password: admin) -> **Network**-> **WAN Port**-> **IPv4**.
2. Press **◀** or **▶**, or the **Switch** soft key to select the **Static IP** from the **Type** field.
3. Enter the desired value in the **IP Address**, **Subnet Mask**, **Gateway**, **Primary DNS** and **Secondary DNS** field respectively.

IPv4 WAN Port	
1. Type:	Static IP < >
2. IP Address:	192.168.1.20
3. Subnet Mask:	255.255.255.0
4. Gateway:	192.168.1.254
5. Primary DNS:	
Back	123 Delete Save

4. Press the **Save** soft key to accept the change or the **Back** soft key to cancel.

You can configure a static IPv6 address for the IP phone, make sure that the IP mode is configured as **IPv6** or **IPv4 & IPv6**.

**To configure a static IPv6 address via phone user interface:**

1. Press **...** -> **Advanced** (default password: admin) -> **Network**-> **WAN Port**-> **IPv6**.
2. Press **◀** or **▶**, or the **Switch** soft key to select the **Static IP** from the **Type** field.
3. Enter the desired value in the **IP Address**, **IPv6 IP Prefix**, **Gateway**, **Primary DNS** and **Secondary DNS** fields respectively.

IPv6 WAN Port	
1. Type:	Static IP < >
2. IP Address:	2005:1:1:12
3. IPv6 IP Prefix:	64
4. Gateway:	2005:1:1:1
5. Primary DNS:	
Back	123 Delete Save

4. Press the **Save** soft key to accept the change or the **Back** soft key to cancel.

If you are using an xDSL modem for IPv4 network connection, you can connect your phone to the Internet via PPPoE mode. Set the WAN port as a PPPoE port. The PPPoE port will perform a PPP negotiation to obtain the IP address. Contact your system administrator for the PPPoE user name and password.

**To configure PPPoE via phone user interface:**

1. Press **...**->**Advanced** (default password: admin) ->**Network**->**WAN Port**->**IPv4**.
2. Press **◀** or **▶**, or the **Switch** soft key to select the **PPPoE** from the **Type** field.
3. Enter the user name and password in the corresponding fields.

IPv4 WAN Port	
1. Type:	PPPoE < >
2. PPPoE User:	<input type="text" value="user1"/>
3. PPPoE Password:	<input type="password" value="....."/>
Back      abc      Delete      Save	

4. Press the **Save** soft key to accept the change or the **Back** soft key to cancel.

**Note**

Wrong network settings may result in inaccessibility of your phone and may also have an impact on your network performance. For more information on these parameters, contact your system administrator.

---

# Customizing Your Phone

---

You can customize your SIP-T46G IP phone by personally configuring certain settings, for example, backlight, time & date, ring tones and E911. You can also manage the contacts and call history.

This chapter provides basic operating instructions for customizing your phone. Topics include:

- [General Settings](#)
- [Audio Settings](#)
- [Contact Management](#)
- [Call History Management](#)
- [Headset Use](#)
- [Bluetooth](#)
- [E911](#)
- [Dial-now](#)
- [Live Dialpad](#)
- [Privacy Mode](#)



If you require additional information or assistance with your new phone, contact your system administrator.

## General Settings

### Language

The default language of the phone user interface is English. If the language of your web browser is not supported by the phone, the web user interface will use English by default. You can change the language for the phone user interface and the web user interface respectively.

**To change the language for the phone user interface:**

1. Press **...** -> **Basic**-> **Language**.
2. Press  or  to select the desired language.

3. Press the desired language.



4. Press **Save** to accept the change.

Text displayed on the phone user interface will change to the selected language.

**To change the language for the web user interface:**

1. Click on **Settings->Preference**.
2. Select the desired language from the pull-down list of **Language**.

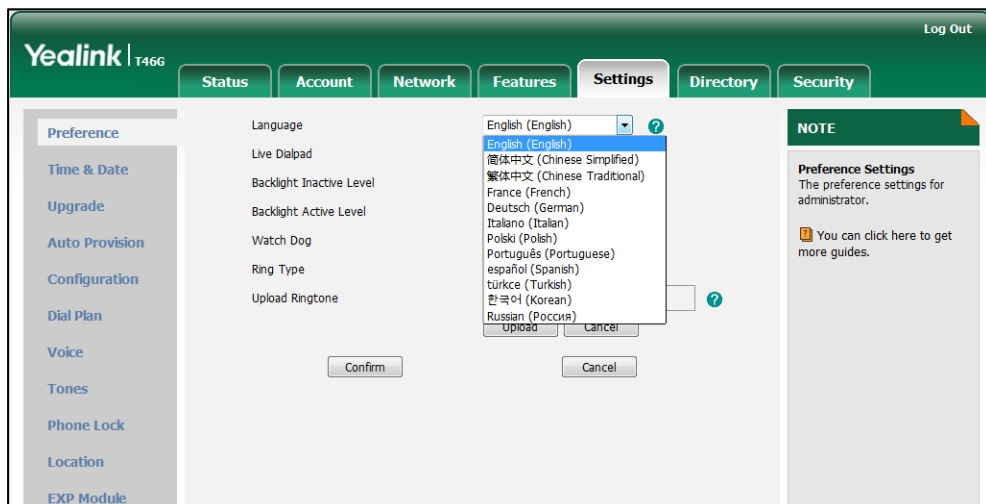

3. Click **Confirm** to accept the change.

Text displayed on the web user interface will change to the selected language.

## Backlight

Backlight has two options:

**Backlight Active Level:** The intensity of the LCD screen when the phone is active. You can change the intensity of the touch screen. Digits (1-10) represent different intensities. 10 is the highest intensity.

**Backlight Inactive Level:** The intensity of the LCD screen when the phone is inactive for the designated backlight time. You can select a low intensity or turn off the backlight.



You can also change the intensity of the LCD screen of EXP40 connected to the SIP-T46G IP phone.

### Note

Backlight time is configurable on Skype for Business Server only. Contact your system administrator for more information.

**To configure the backlight via phone user interface:**

1. Press ... ->**Basic**->**Display**->**Backlight**.
2. Press ◀ or ▶ , or the **Switch** soft key to select the desired value from the **Backlight Active Level** field.
3. Press ◀ or ▶ , or the **Switch** soft key to select the desired value from the **Backlight Inactive Level** field.

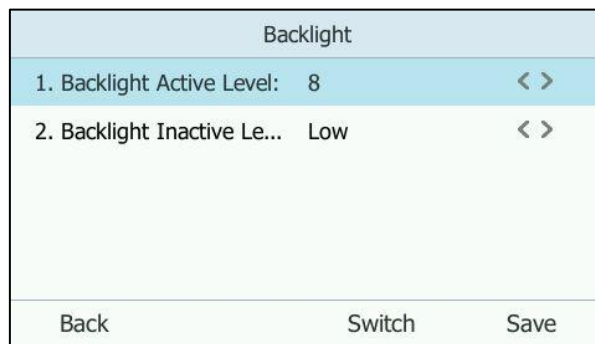

4. Press the **Save** soft key to accept the change or the **Back** soft key to cancel.

Backlight is configurable via web user interface at the path **Settings->Preference**.

## Contrast

You can only configure the contrast of the expansion module EXP40 connected to the SIP-T46G IP phone to a comfortable level on the phone. Ensure that the expansion module has been connected to the phone before configuration. The intensity of contrast ranges from 1 to 10 and the highest intensity is 10.

**To configure the contrast via phone user interface:**

1. Press **Menu**->**Basic**->**Display**->**Contrast Setting**.  
If EXP40 is not connected to the phone, the Contrast Setting screen displays "No EXP".
2. Press ◀ or ▶ , or the **Switch** soft key to increase or decrease the intensity of contrast.

The default contrast level is "6".

Contrast		
1. Contrast:	6	< >
Back	Switch	Save

3. Press the **Save** soft key to accept the change or the **Back** soft key to cancel.

## Time & Date

The time and date are displayed in the middle of the status bar. You can configure the phone to obtain the time and date from the SNTP server automatically, or configure the time and date manually. If the phone cannot obtain the time and date from the Simple Network Time Protocol (SNTP) server, contact your system administrator for more information.

**To configure the SNTP settings via phone user interface:**

1. Press **\*\*\* ->Basic->Date & Time->General->SNTP Settings**.
2. Press **◀** or **▶**, or the **Switch** soft key to select the time zone that applies to your area from the **Time Zone** field.  
The default time zone is "GMT+8".
3. Enter the domain names or IP addresses of SNTP servers in the **NTP Server1** and **NTP Server2** field respectively.
4. Press **◀** or **▶**, or the **Switch** soft key to select automatic, enabled and disabled from the **Daylight Saving** field.
5. Press **◀** or **▶**, or the **Switch** soft key to select the desired location from the **Location** field.

General		
1. Time Zone:	GMT+8	< >
2. NTP Server1:	<input type="text" value="time.windows.com"/>	
3. NTP Server2:	<input type="text" value="time.nist.gov"/>	
4. Daylight Saving:	Automatic	< >
5. Location:	China(Beijing)	< >
Back	Switch	Save

6. Press the **Save** soft key to accept the change or press the **Back** soft key to cancel.

**Note**

Please refer to [Appendix A - Time Zones](#) for the list of available time zones on the IP phone.



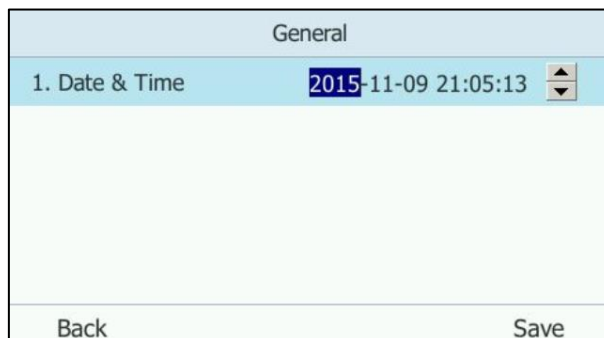

**To configure the date and time manually via phone user interface:**

1. Press **...->Basic->Date &Time->General->Manual Settings**.
2. Enter the specific date and time or press  or  to edit specific date and time in the corresponding fields.



3. Press **Save** to accept the change.  
The time and date displayed on the LCD screen will change accordingly.

**To configure the time and date format via phone user interface:**

1. Press **...->Basic->Date &Time ->Time & Date Format**.
2. Press  or , or the **Switch** soft key to select the desired date format from the **Date Format** field.
3. Press  or , or the **Switch** soft key to select the desired time format (**12 Hour** or **24 Hour**) from the **Time Format** field.

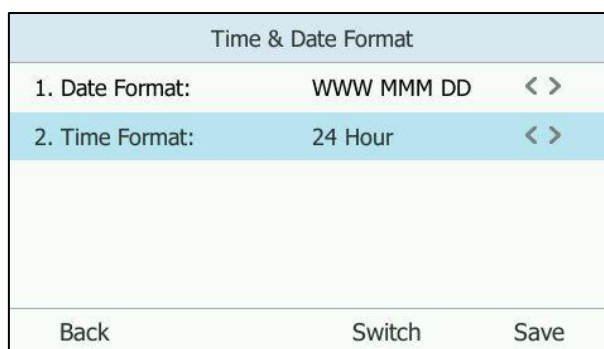

4. Press the **Save** soft key to accept the change or the **Back** soft key to cancel.  
There are 7 available date formats. For example, for the date format "WWW DD MMM", "WWW" represents the abbreviation of the week, "DD" represents the two-digit day, and "MMM" represents the first three letters of the month.

The date formats available:

Date Format	Example (2016-2-16)
WWW MMM DD	Tue Feb 16
DD-MMM-YY	16-Feb-16
YYYY-MM-DD	2016-02-16
DD/MM/YYYY	16/02/2016
MM/DD/YY	02/16/16
DD MMM YYYY	16 Feb 2016
WWW DD MMM	Tue 16 Feb

Time and date format is configurable via web user interface at the path **Settings->Time & Date**.

To configure the DHCP Time via phone user interface:

1. Press **...**->**Basic**->**Date & Time**->**DHCP Time**.
2. Press **←** or **→** , or the **Switch** soft key to select **Enabled** from the **DHCP Time** field.

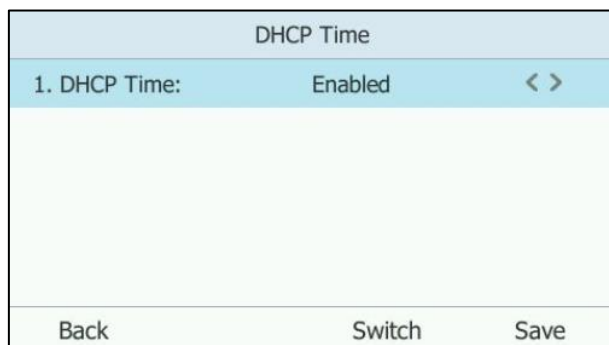

3. Press the **Save** soft key to accept the change or press the **Back** soft key to cancel.

DHCP time is configurable via web user interface at the path **Settings->Time & Date-->DHCP Time**.

## Administrator Password

The **Advanced** option is only accessible to the administrator. The default administrator password is “admin”. For security reasons, you should change the default administrator password as soon as possible.

To change the administrator password via phone user interface:

1. Press **...** ->**Advanced** (default password: admin) ->**Set Password**.
2. Enter the old password in the **Current PWD** field.
3. Enter the new password in the **New PWD** field.

4. Enter the new password in the **Confirm PWD** field.

5. Press the **Save** soft key to accept the change or the **Back** soft key to cancel.

Administrator password is configurable via web user interface at the path **Security->Password**.

## Key as Send

You can set the "#" key or "\*" key to perform as a send key while dialing.

**To configure key as send via phone user interface:**

1. Press **...**->**Features**->**Key as Send**.
2. Press **◀** or **▶**, or the **Switch** soft key to select **#** or **\*** from the **Key as Send** field, or select **Disabled** to disable this feature.

3. Press the **Save** soft key to accept the change or the **Back** soft key to cancel.

Key as send is configurable via web user interface at the path **Features->General Information->Key as send**.

## Phone Lock

If the Skype for Business Server is configured to forcibly lock the phone, user can use phone lock feature to lock the phone to prevent it from unauthorized use. And the IP phone will prompt the user to configure an unlock PIN at the initial sign-in.

### To set unlock PIN:

1. Enter the unlock PIN (length must be between 6 and 15) in the **New PIN** field.
2. Enter the unlock PIN again in the **Confirm PIN** field.
3. Press the **Save** soft key.

When the unlock PIN is configured successfully, you can do one of the following to lock your phone:

- Long press  for two seconds to lock the phone immediately when the phone is idle.
- Press **...** -> **Basic**-> **Phone Unlock PIN**.  
Select **Lock the phone**, and then press the **OK** soft key.
- The phone will be locked automatically when it has been inactive for the designated time (in seconds). The time is configurable on Skype for Business server only.

### When the locked phone is idle:

Line keys, digit keys, # key, \* key, volume key, headset key and speakerphone key are available and other keys on the phone are locked.

Pick up the handset or press the first line key or press the Speakerphone key to enter the pre-dialing screen, enter the emergency phone number, and then press , or press **Send** soft key to place a call.

You can only place an emergency call and cannot make other outgoing call. And you cannot search contacts on the pre-dialing screen.

### When the locked phone receives an incoming call:

You can answer, reject or mute the incoming calls only.

**When the locked phone engages in a call:**

You can place the call on hold, mute or unmute the call, end the call or dial emergency numbers only.

**Note**

Phone status will change to Away after the phone is locked and the phone will revert to previous status when unlocked. For more information, refer to [Changing Presence Status](#) on page 25.

**To change the phone Unlock PIN via phone user interface:**

1. Press **...**->**Basic**->**Phone Unlock PIN**->**Change PIN**.
2. Enter the current unlock PIN in the **Current PIN** field.
3. Enter the new unlock PIN in the **New PIN** field.
4. Enter the new unlock PIN again in the **Confirm PIN** field.

Phone Unlock PIN	
1. Current PIN:	<input type="password" value="..."/>
2. New PIN:	<input type="password" value="..."/>
3. Confirm PIN:	<input type="password" value="..."/>
<div style="display: flex; justify-content: space-between; padding: 5px;"> <span>Back</span> <span>123</span> <span>Delete</span> <span>Save</span> </div>	

5. Press the **Save** soft key to accept the change.

Unlock PIN is configurable via web user interface at the path **Settings->Phone Lock**.

**To unlock the phone via phone user interface:**

1. Enter the PIN in the Unlock PIN field.

11:13 Fri Feb 19			
			
Lin Wei			
<input type="password" value="....."/>			
<div style="display: flex; justify-content: space-between; padding: 5px;"> <span>NewCall</span> <span>123</span> <span>Delete</span> <span>Unlock</span> </div>			

2. Press the **Unlock** soft key or **OK** to unlock the phone.

**Note**

You can also unlock the phone by administrator password.

**To disable the phone lock feature via phone user interface:**

1. Press **...** ->**Advanced** (default password: admin) ->**Phone Lock**.
2. Press **◀** or **▶** , or the **Switch** soft key to select **Disabled** from the **Lock the phone** field.



3. Press the **Save** soft key to accept the change.  
The phone user interface prompts "Reboot now?".
4. Press **OK** soft key.  
The phone lock feature will be disabled after a reboot.

Phone lock is configurable via web user interface at the path **Settings->Phone Lock**.

## Audio Settings

### Volume

You can press the volume key to adjust the ringer volume when the phone is idle or is ringing. You can also press the volume key to adjust the receiver volume of currently engaged audio device (handset, speakerphone or headset) when the phone is in use.

**To adjust the volume when the phone is idle:**

1. Press  to adjust the ringer volume.

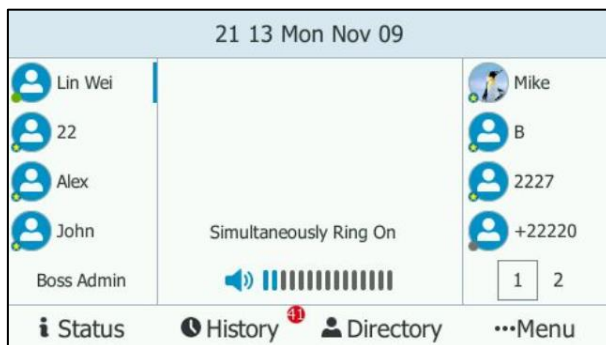

**Note** If ringer volume is adjusted to minimum, the  icon will appear on the top-right corner of LCD screen.



To adjust the volume when the phone is ringing:

1. Press  to adjust the ringer volume.

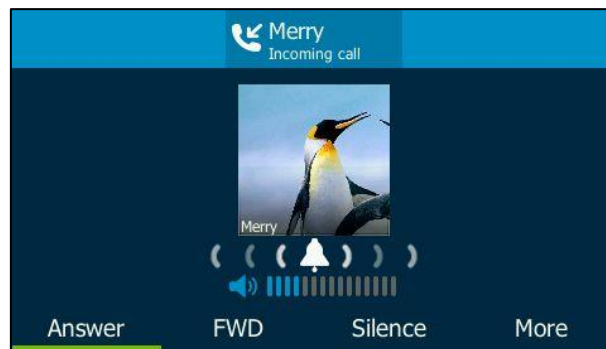

To adjust the volume when the phone is during a call:

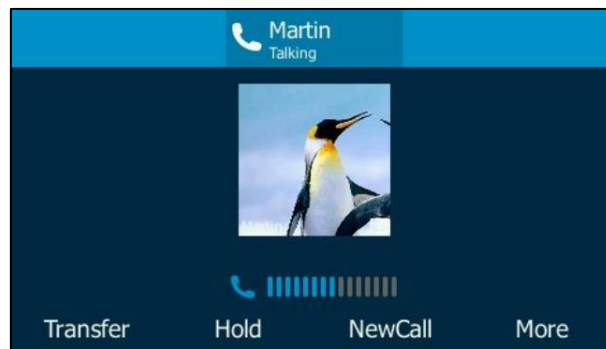

1. Press  to adjust the volume of currently engaged audio device (handset, speakerphone or headset).



## Ring Tones

Ring tones are used to indicate incoming calls and distinguish your phone from your neighbor's.

To select a ring tone for the phone via phone user interface:

1. Press **\*\*\*->Basic->Sound->Ring Tones**.
2. Press  or  to select the desired ring tone.

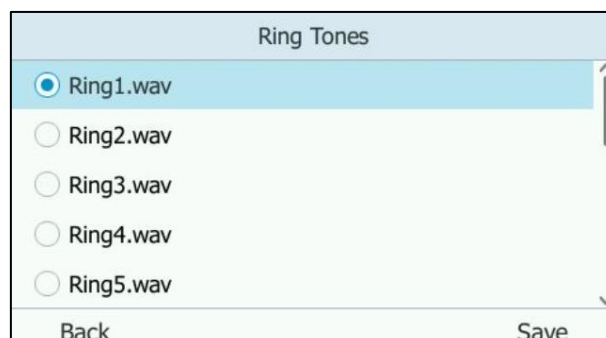

3. Press the **Save** soft key to accept the change or the **Back** soft key to cancel.

A ring tone for the phone is configurable via web user interface at the path **Settings->Preference->Ring Type**.

**To upload a custom ring tone for the phone via web user interface:**

1. Click on **Settings->Preference**.
2. In the **Upload Ringtone** field, click **Browse...** to locate a ring tone file (the file format must be \*.wav) from your local system.

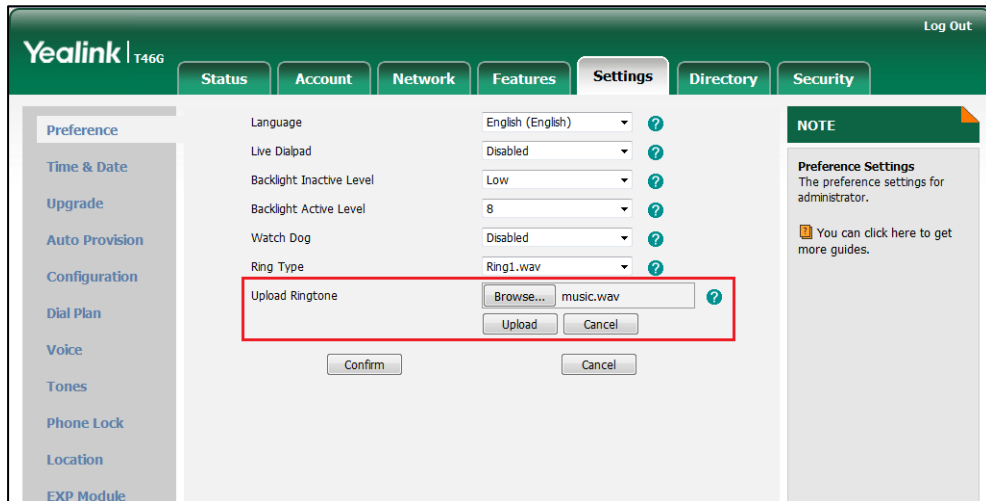

3. Click **Upload** to upload the file.

**Note**

The priority of ring tone for an incoming call on the phone is as follows: Contact ring tone (refer to [Adding Local Contacts](#)) ->Phone ring tone.

Both single custom ring tone file and total custom ring tone files must be within 100KB. Uploading custom ring tones for your phone is configurable via web user interface only.

## Contact Management

The phone directory displays local directory and Skype for Business directory.

- Local directory (All or Favorites)
- Skype for Business directory (e.g., Favorites, Delegates, Bosses or Other Contacts)

If boss-admin is configured, the Bosses or Delegates group appears depending on your role. For more information on boss-admin feature, refer to [Boss-Admin Feature](#) on page 123. You can add more Skype for Business groups via Skype for Business client.

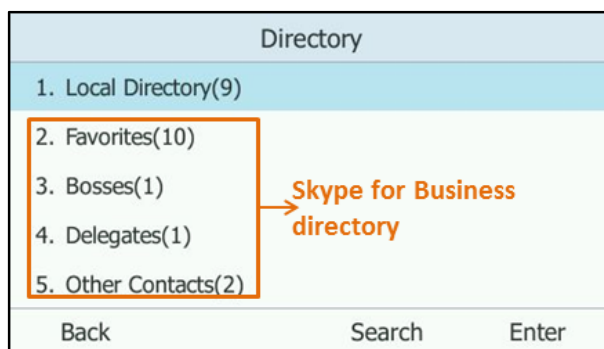

## Skype for Business Directory

The Skype for Business directory on your phone displays all Skype for Business contacts of your Microsoft Skype for Business client. You can view Skype for Business contacts on the phone, but you cannot add, edit or delete Skype for Business contacts on the phone.

## Adding Skype for Business Contacts

**To add contacts via Skype for Business client:**

1. Enter a few continuous characters of the contact name or continuous numbers of the contact number in the Search field.

The contacts whose name or phone number matches the characters entered will appear in your contacts list.

- Right-click the contact, and then click **Add to Contacts List**.

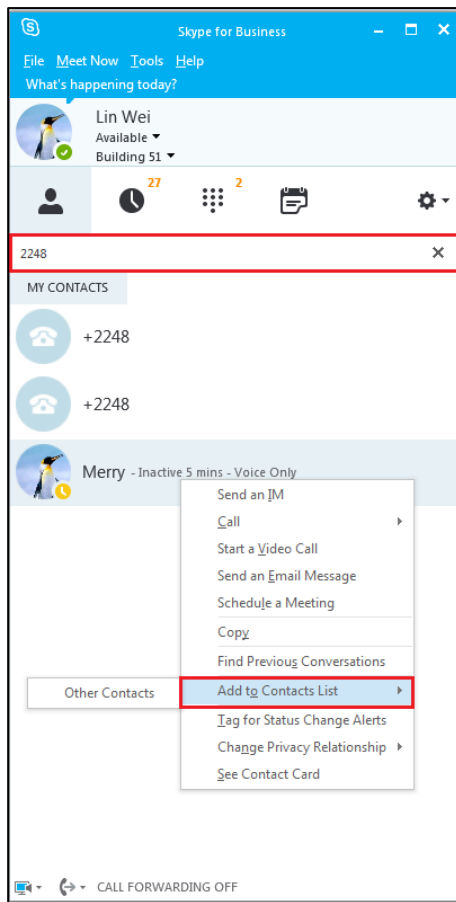

- Select the desired group.  
The contact is added to the selected group.

## Viewing Skype for Business Contacts



You can view the following information about each contact on the phone:

- The contact's presence icon
- The contact's display name
- The contact's avatar
- The detailed information of the contact (e.g., name, mail address)

### Note

For more information on the presence icon, refer to [Icon Instructions](#) on page 3.

**To view the Skype for Business contacts:**

- Press .
- Press  or  to select the Skype for Business group (e.g., Favorites or Other Contacts) that contains the desired contact.

If boss-admin is configured, the Bosses or Delegates group appears depending on

your role. For more information on boss-admin feature, refer to [Boss-Admin Feature](#) on page 123.

3. Press the **Enter** soft key.

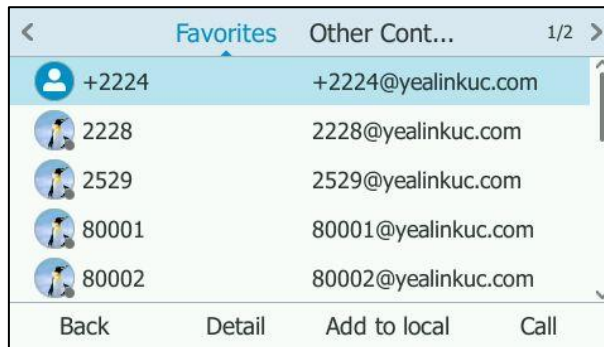

4. Press  $\uparrow$  or  $\downarrow$  to select the desired contact.
5. Press **Detail** soft key.

The detailed information (e.g., display name, address or email) of the contact appears on the LCD screen.



6. Press the **Back** soft key to return to the previous screen.

## Skype for Business Favorites

You can add your Skype for Business contacts as favorites via your Skype for Business client only. You can view Skype for Business favorites on the phone.

## Adding Skype for Business Favorites

To add contacts as favorites via Skype for Business client:

1. Right-click a contact.
2. Click Add to Favorites.

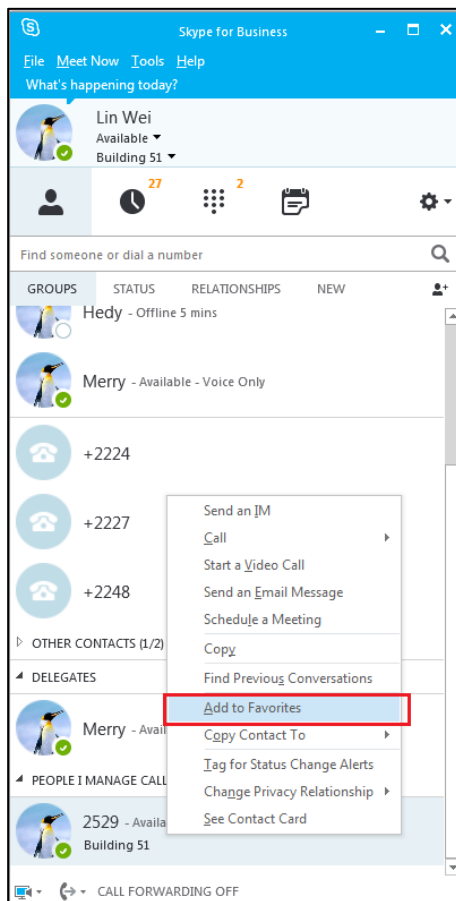

## Viewing Skype for Business Favorites

You can view the Skype for Business favorites on the idle screen or Skype for Business favorites screen.

**To view the Skype for Business favorites on the idle screen:**

1. By default, Skype for Business favorites are displayed behind the local favorites on the idle screen.



**To view the Skype for Business favorites in the directory:**

1. Press -> **Favorites**.

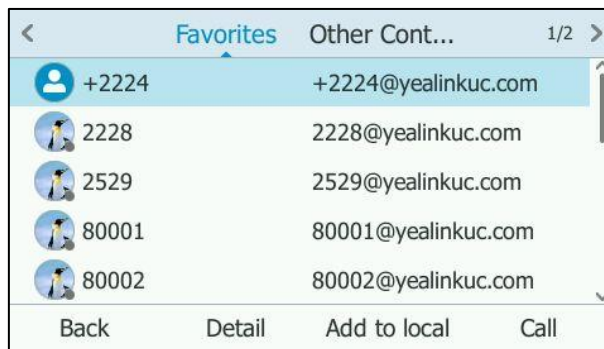

2. Press or to select the desired contact.
3. Press **Detail** soft key.

The detailed information (e.g., display name, address or email) of the contact appears on the LCD screen.



4. Press the **Back** soft key or press to return to the previous screen.

## Local Directory

Yealink IP phones also maintain a local directory. The local directory can store up to 1000 contacts. When adding a contact to the local directory, in addition to name and phone numbers, you can also specify the ring tone and group for the contact. Contacts can be added either one by one or in batch using a local contact file. Yealink IP phones support both \*.xml and \*.csv format contact files, but only support \*.xml format download for local contact file.

### Adding Local Contacts

You can add contacts to the local directory in the following ways:



- Manually
- From Skype for Business directory

### Adding Local Contacts Manually

To add a contact to the local directory manually:

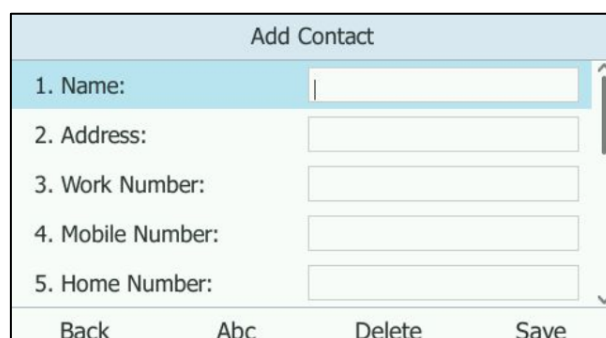
1. Press  -> **Local Directory**->**All Contacts**.
2. Press the **Add** soft key.
3. Enter name, address, work number, mobile number, home number, title and email in the corresponding fields.



4. Press  or  , or the **Switch** soft key to select the desired ring tone from the **Ring** field.
5. Press the **Save** soft key to accept the change or the **Back** soft key to cancel.

#### Note



If the contact name already exists in the directory, the LCD screen will prompt "Contact name existed!".

Local directory is configurable via web user interface at the path **Directory->Local Directory**.





## Adding Local Contacts from Skype for Business Directory

To add a local contact from Skype for Business directory via phone user interface:

1. Press .
2. Press  or  to select the Skype for Business group (e.g., Favorites or Other Contacts) that contains the desired contact.

If boss-admin is configured, the Bosses or Delegates group appears depending on your role. For more information on boss-admin feature, refer to [Boss-Admin Feature](#) on page 123.



3. Press **Enter** soft key.
4. Press  or  to select the desired contact.
5. Press the **Add to local** soft key.

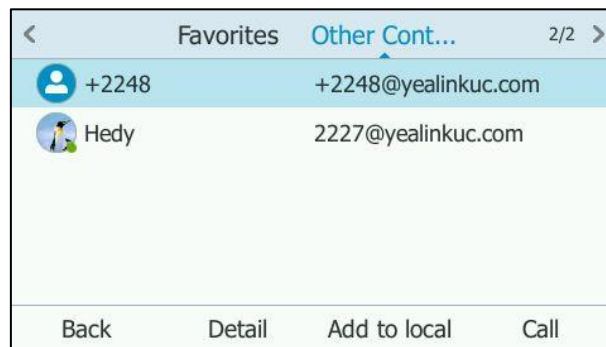

6. Press  or  to edit the contact information.

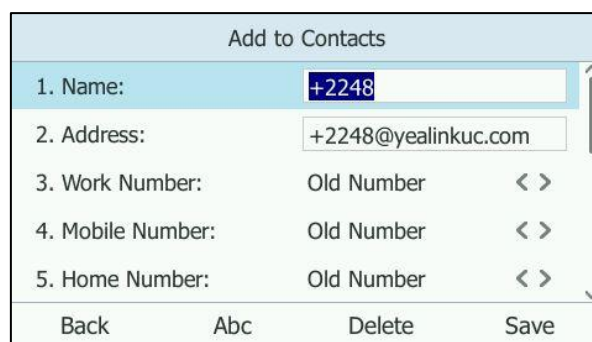

- Press the **Save** soft key to add a contact to the local directory.

The entry is successfully saved to the local directory.

## Viewing Local Contacts

You can view the following information about each contact on the phone:

- The contact's display name
- The contact's avatar
- The detailed information of the contact (e.g., name, mail address)





### Note

You can't view the presence status of the local contacts. For more information on the presence icon, refer to [Icon Instructions](#) on page 3.

To view the local directory:

- Press  -> **Local Directory**.



- Press  or  to select the desired group.
- Press  or  to highlight the desired contact.

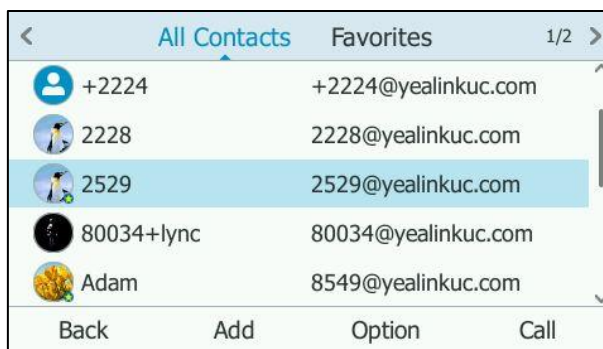

- Press the **Option** soft key, and then press  $\uparrow$  or  $\downarrow$  to select **Detail** from the prompt list.

2529	
1. Name:	<input type="text" value="2529"/>
2. Address:	<input type="text" value="2529@yealinkuc.com"/>
3. Work Number:	<input type="text"/>
4. Mobile Number:	<input type="text"/>
5. Home Number:	<input type="text"/>
Back      Abc      Delete      Save	

- Press the **Back** soft key to return to the pervious screen.

## Editing Local Contacts

To edit a contact in the local directory:

- Press  -> **Local Directory**.
- Press  $\uparrow$  or  $\downarrow$  to select the desired group.
- Press  $\uparrow$  or  $\downarrow$  to highlight the desired contact.
- Press the **Option** soft key, and then press  $\uparrow$  or  $\downarrow$  select **Detail** from the prompt list.
- Press  $\uparrow$  or  $\downarrow$  to highlight the contact information and then edit.

You can edit name, address, work number, mobile number, home number, title and email in the corresponding fields.







2529	
1. Name:	<input type="text" value="2529"/>
2. Address:	<input type="text" value="2529@yealinkuc.com"/>
3. Work Number:	<input type="text"/>
4. Mobile Number:	<input type="text"/>
5. Home Number:	<input type="text"/>
Back      Abc      Delete      Save	

- Press the **Save** soft key to accept change or the **Back** soft key to cancel.

Local directory is configurable via web user interface at the path **Directory->Local Directory**.

## Deleting Local Contacts

To delete a contact from the local directory:

1. Press  -> **Local Directory**.
2. Press  or  to select the desired group, and then press the **Enter** soft key.
3. Press  or  to highlight the desired contact.
4. Press the **Option** soft key, and then press  or  to select **Delete** from the prompt list.

The LCD screen prompts "Delete selected item?".

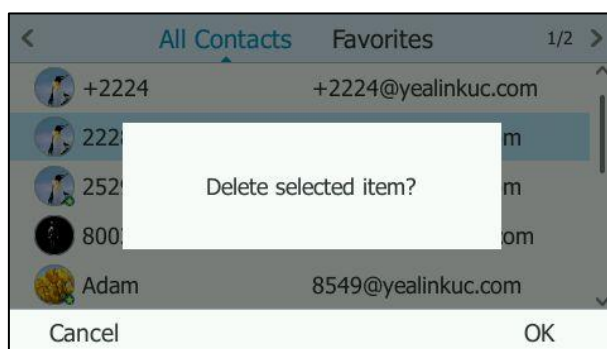

5. Press **OK** soft key to confirm the deletion or the **Cancel** soft key to cancel.

You can also delete all contacts by pressing the **Option** soft key, and then select **Delete All**.

Deleting a contact or all contacts is configurable via web user interface at the path **Directory->Local Directory**.

## Importing/Exporting Contact Lists

You can manage your phone's local directory via phone user interface or web user interface. But you can only import or export the contact list via web user interface.

To import an XML contact list file via web user interface:

1. Click on **Directory->Local Directory**.

- Click **Browse...** to locate a contact list file (the file format must be \*.xml) from your local system.

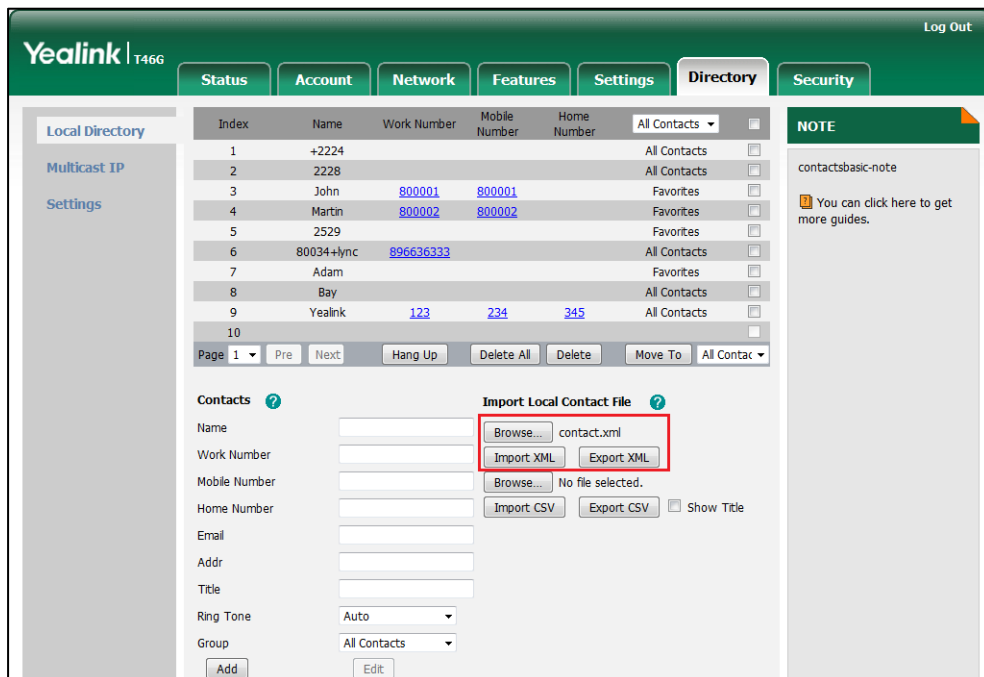

- Click **Import XML** to import the contact list.  
The web user interface prompts "The original contact will be covered, continue?".
- Click **OK** to complete importing the contact list.

**To import a CSV contact list file via web user interface:**

- Click on **Directory**->**Local Directory**.
- Click **Browse...** to locate a contact list file (the file format must be \*.csv) from your local system.
- (Optional) Check the **Show Title** checkbox.

It will prevent importing the title of the contact information which is located in the first line of the CSV file.

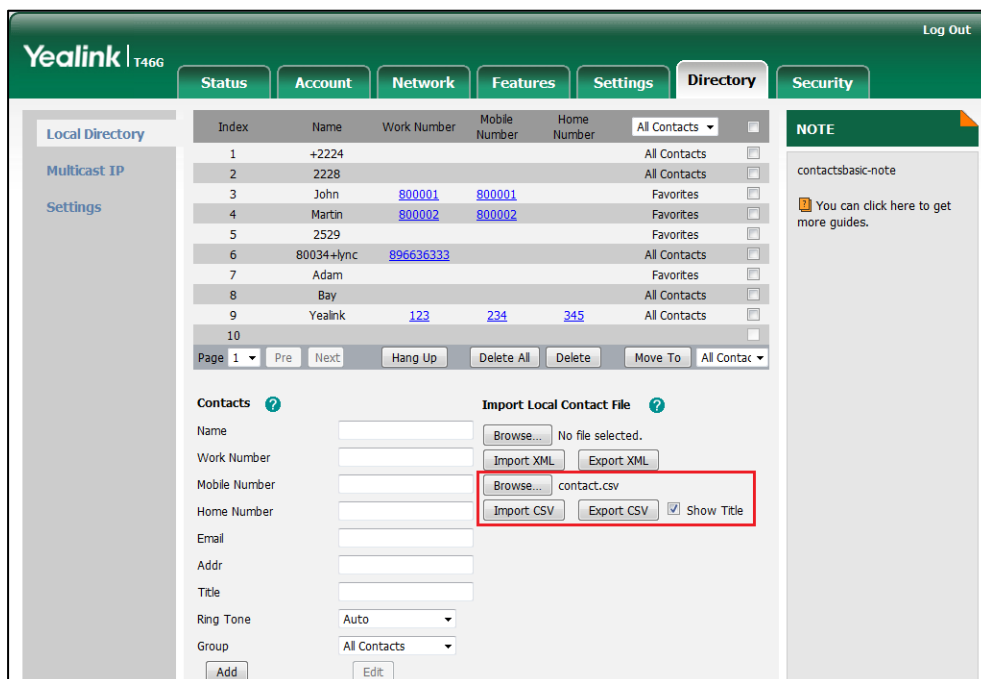

4. Click **Import CSV** to import the contact list.
5. (Optional) Mark the **On** radio box in the **Del Oldcontact** field.  
It will delete all existing contacts while importing the contact list.
6. Select the contact information you want to import into the local directory from the pull-down list of **Index**.  
At least one item should be selected to be imported into the local directory.

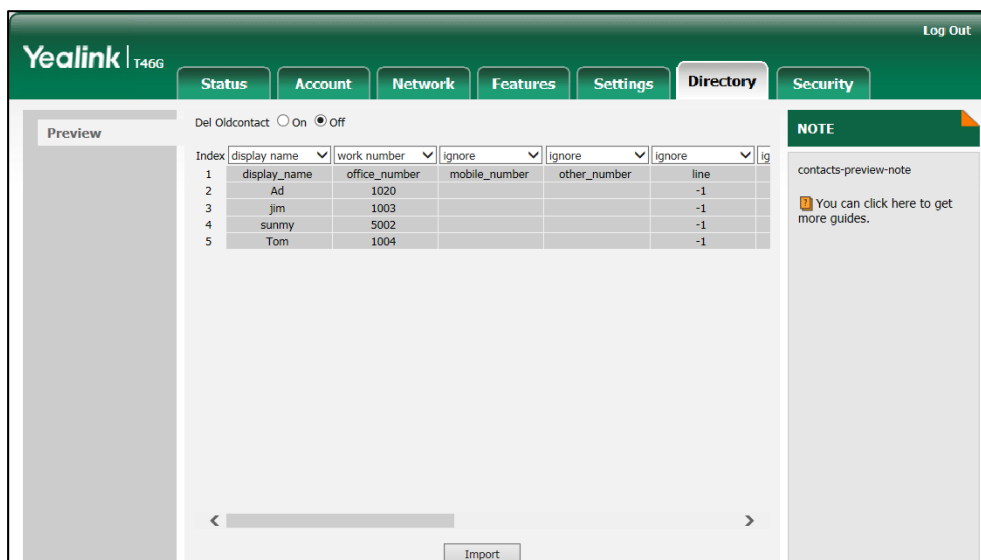

7. Click **Import** to complete importing the contact list.

To export a contact list via web user interface:

1. Click on **Directory**->**Local Directory**.
2. Click **Export XML** (or **Export CSV**).
3. Click **Save** to save the contact list to your local system.

## Local Favorites

Favorites are the contacts in your directory that you call most often. You need to assign an index number for a favorite contact. Local favorites display consecutively, according to their index number. The contact with the lowest number displays first.





## Adding Local Favorites

You can add the local favorites manually or add local contacts as favorites.

To add a local favorite via phone user interface:

1. Press ->**Local Directory**->**Favorites**.
2. Press **Add** soft key.
3. Enter the contact name, address, work number, mobile number, home number, title and email in the corresponding fields.

Add Contact	
1. Name:	<input type="text"/>
2. Address:	<input type="text"/>
3. Work Number:	<input type="text"/>
4. Mobile Number:	<input type="text"/>
5. Home Number:	<input type="text"/>
<div style="display: flex; justify-content: space-between;"> <span>Back</span> <span>Abc</span> <span>Delete</span> <span>Save</span> </div>	

4. Press  or  , or the **Switch** soft key to select the desired ring tone from the **Ring** field.
5. Press  or  , or the **Switch** soft key to select the index number from the **Index** field.

The valid value of index number ranges from Null to 27 and the lowest number is Null. The contact with the lowest index number displays first.

Add Contact			
6. Title:	nul		^
7. Email:	null		
8. Ring:	Auto	< >	
9. Group:	Favorites	< >	
10. Index:	7	< >	v
Back	abc	Delete	Save

6. Press the **Save** soft key to accept the change or the **Back** soft key to cancel.

Adding a local favorite is configurable via web user interface at the path **Directory->Local Directory**.

**To add a local contact as the local favorite via phone user interface:**

1. Press ->**Local Directory->All Contacts**.
2. Press or to highlight the desired contact.
3. Press **Option** soft key, and then press or to select **Detail** from the prompt list.
4. Press the **OK** soft key.
5. Press or , or **Switch** soft key to select **Favorites** from the **Group** filed.
6. Press or , or the **Switch** soft key to select the desired index number from the **Index** field.

Add Contact			
6. Title:			^
7. Email:			
8. Ring:	Auto	< >	
9. Group:	Favorites	< >	
10. Index:	3	< >	v
Back	Switch	Save	

7. Press the **Save** soft key to accept the change or the **Back** soft key to cancel.

The entry is successfully saved to the local favorite.

Adding a local contact as the local favorite is configurable via web user interface at the path **Directory->Local Directory**.



## Viewing Local Favorites

You can view the local favorites on the idle screen or local favorites screen.

**To view the local favorites on the idle screen:**

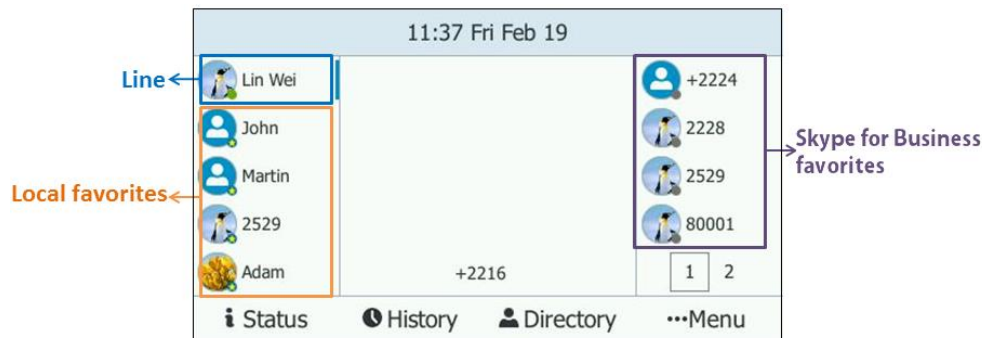

1. The local favorite is indicated by the icon  on the idle screen.
2. By default, local favorites are displayed before the Skype for Business favorites on the idle screen.

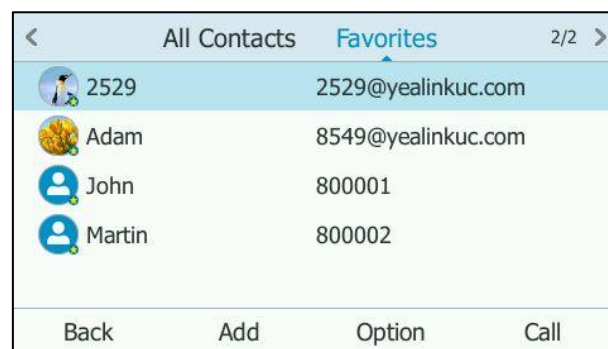

**To view the local favorites in the local directory:**

1. Press  -> Local Directory-> Favorites.



2. Press the **Option** soft key, and then select **Detail** from the prompt list.  
The detailed information (e.g., name, address, office number, mobile number, other number, title and email) of the contact appears on the screen.
3. Press  or  to view the detail.





## Reordering Local Favorites

To reorder your local favorites, assign the local favorite a different index number.

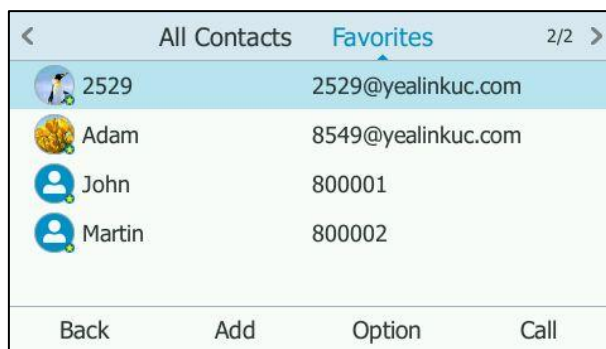

**To reorder your favorites:**

1. Press  -> **Local Directory**->**Favorites**.

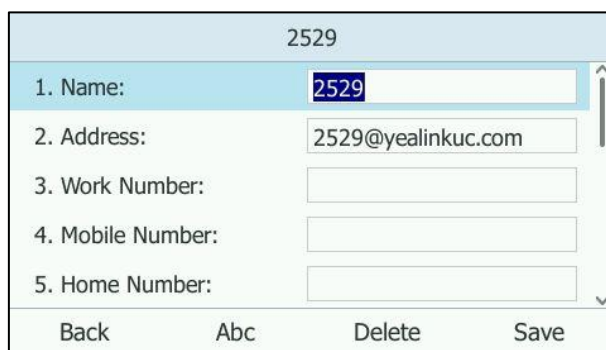

2. Press  or  to highlight the desired contact.
3. Press **Option** soft key, and then press  or  to select **Detail** from the prompt list.



4. Press  or , or the **Switch** soft key to select the desired index number from the **Index** field.

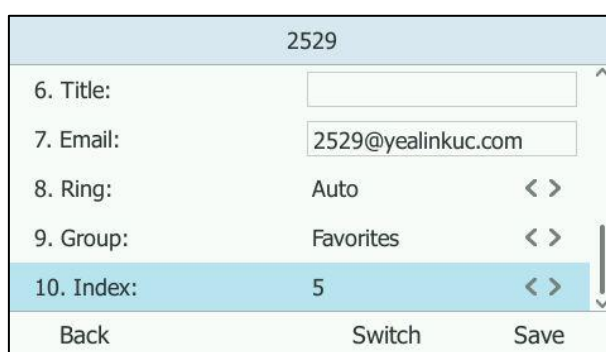

5. Press the **Save** soft key to accept the change or the **Back** soft key to cancel.

The phone uses the new index number to order the favorite.

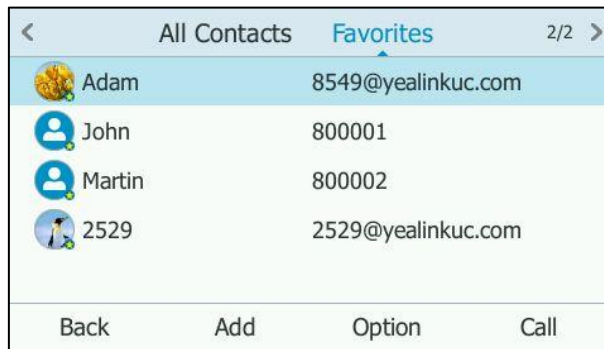

## Managing Local Favorites

Local favorites and Skype for Business favorites of SIP-T46G IP phones are displayed on the idle screen. By default, local favorites are displayed before the Skype for Business favorites.

You can configure whether to display local favorites on the idle screen and configure the display order of the local favorites.

Local favorite is indicated by the icon . The following figure shows a sample Favorites list on the idle screen.

John, Martin, 2529 and Adam are your local favorites. +2224, 2228, 2529 and 80001 are your Skype for Business favorites.

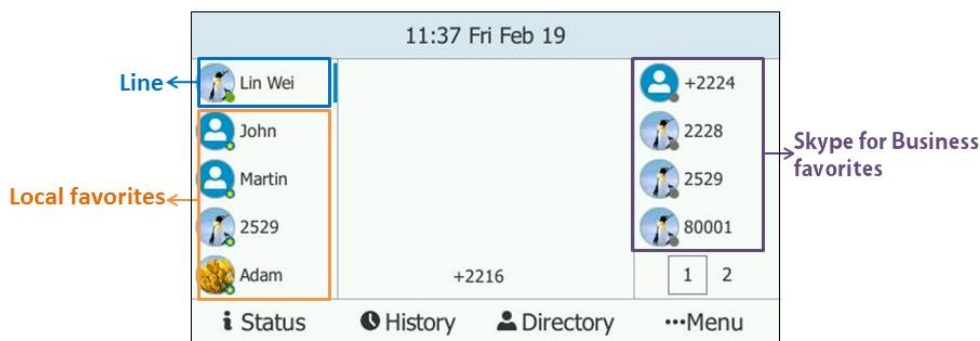

When the number of favorite contacts is more than 9, you can press the tenth line key to turn pages to view other favorites.

**To configure the display priority of local favorite via web user interface:**

1. Click on **Directory->Settings**.
2. Select the desired value from the pull-down list of **Local Favorite**.
3. Depending on your selection:
  - If **Disabled** is selected, only the Skype for Business favorites are displayed on the idle screen.

- If **Preferential** is selected, local favorites will be displayed before the Skype for Business favorites on the idle screen.
- If **General** is selected, the local favorites will be displayed behind the Skype for Business favorites on the idle screen.

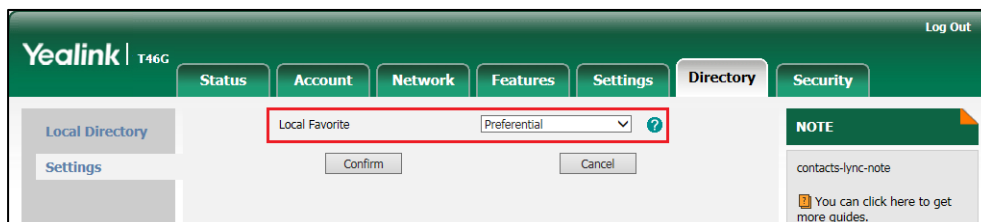

4. Click **Confirm** to accept the change.

**Note** You can configure the display priority of local favorite via web user interface only.







## Placing Calls to Contacts



To place a call from the idle screen:

1. Press desired line key (indicating a favorite) when the phone is idle.  
You can press the tenth line key to turn pages to select more contacts.



To place a call to a contact from the directory:

1. Press .
  2. Press  or  to select the desired group and press the **Enter** soft key.
  3. Press  or  to highlight the desired contact.
  4. Press the **Call** soft key or .
- If a contact has only one number, the contact number will be dialed out directly.

- If a contact has multiple numbers, you can press  or  to select the desired number, and then press the **Call** soft key or press .

John	
Work Number:	2248
Mobile Number:	2529
Home Number:	80023
<div style="display: flex; justify-content: space-between;"> <span>Back</span> <span>Call</span> </div>	



## Searching for Contacts

You can search the contacts on the pre-dialing screen or Skype for Business directory.

- On the pre-dialing screen, you can search for Skype for Business contacts, local contacts and Microsoft Outlook contacts.
- In the Skype for Business directory, you can only search for Skype for Business contacts.



### To search for contacts on the pre-dialing screen:

1. Enter the first few continuous characters of the contact name or the contact number. The phone performs an Intelligent search (e.g., press the digit key 2 to search the letters "2, a, b and c").

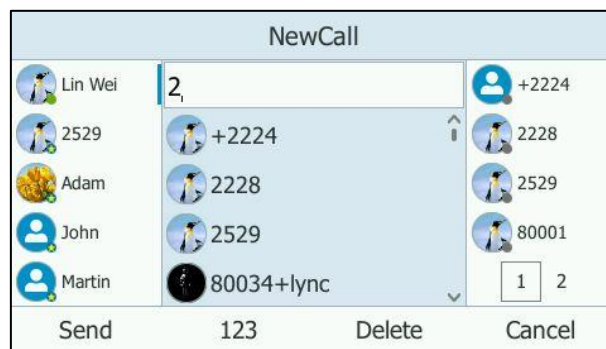
The entries whose name or phone number matches the characters entered will appear on the LCD screen. You can press  or  to scroll to the desired contact, and then place a call to the contact.



### To search for contacts in the Skype for Business directory:

1. Press .
2. Press  or  to select the Skype for Business group (e.g., Favorites or Other Contacts) that contains the desired contact.

If boss-admin is configured, the Bosses or Delegates group appears depending on your role. For more information on boss-admin feature, refer to [Boss-Admin Feature](#) on page 123.



3. Press the **Search** soft key.

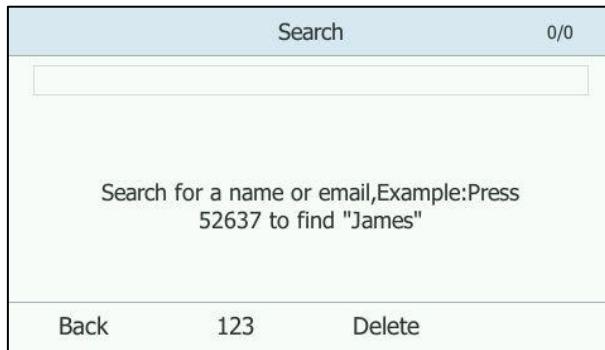

4. Enter the first few continuous characters of the contact name or the contact number. (e.g., press the digit key 5 to search the letter "5, j, k and l"). The entries whose name or phone number matches the characters entered will appear on the LCD screen.

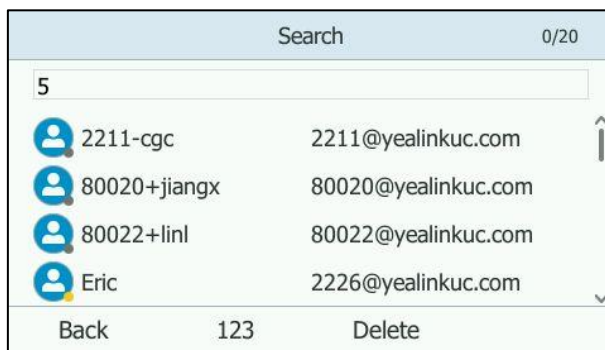

You can also configure the IP phone to search for contacts after the designated time when on the pre-dialing screen.

To configure dial search delay via web user interface:

1. Click on **Features->General information**.
2. Enter the desired value (in seconds) in the **Dial Search Delay** field.

The default value is "1".

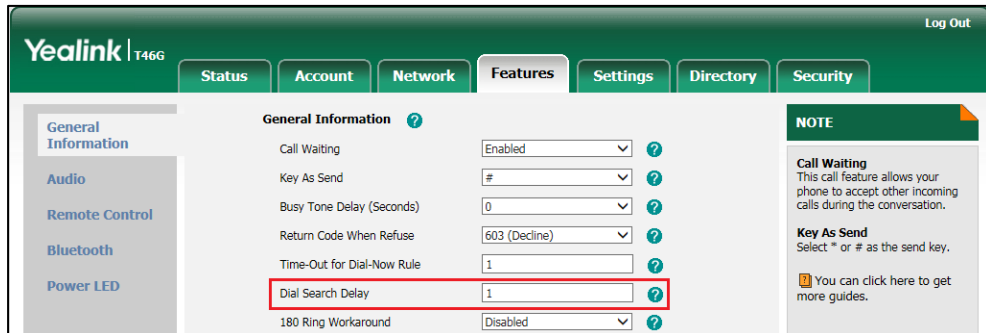

3. Click **Confirm** to accept the change.

**Note** Dial search delay feature is configurable via web user interface only.

## Call History Management

The SIP-T46G IP phone maintains call history lists of Missed, Placed, Received and Forwarded. Each call history list supports up to 100 entries. You can view the call history, place a call, or delete an entry from the call history list.

History record feature is enabled by default, if you don't want to save the call history, you can disable the feature.

To disable history record via phone user interface:

1. Press **...->Features>History Setting**.
2. Press **◀** or **▶**, or the **Switch** soft key to select **Disabled** from the **History Record** field.

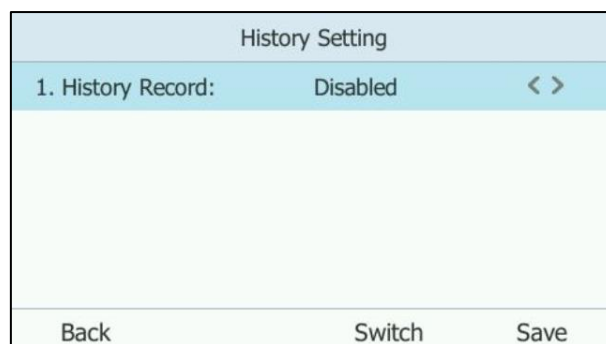





3. Press the **Save** soft key to accept the change or the **Back** soft key to cancel.

**To view the call history:**

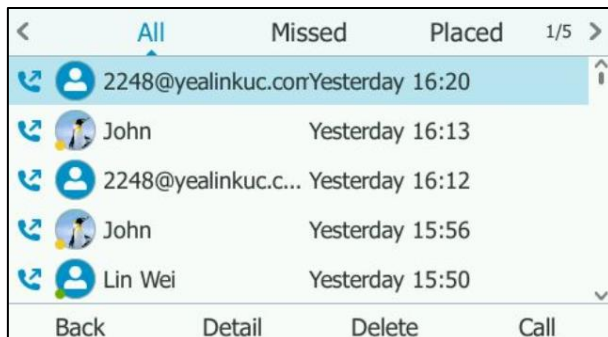
1. Press .

The LCD screen displays all call records.



2. Press  or  to switch between **All, Missed, Placed, Received** and **Forwarded** call lists.
3. Press  or  to select the desired entry.
4. Press the **Detail** soft key.

The detailed information (e.g., avatar, display name or number) of the entry appears on the LCD screen.

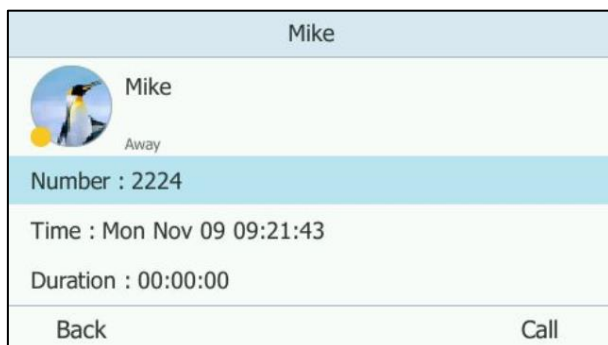





5. Press the **Back** soft key.

**To place a call from the call history list:**

1. Press .

The LCD screen displays all call record.



2. Press  or  to switch between **All, Missed, Placed, Received** and **Forwarded** call lists.
3. Press  or  to select the desired entry.
4. Press  or the **Call** soft key.

**To delete an entry from the call history list:**

1. Press the **History** soft key.
2. Press  or  to switch between **All, Missed, Placed, Received** and **Forwarded**



call lists.

3. Press  or  to select the desired entry.
4. Press the **Delete** soft key.

## Headset Use

If you want to use a wired headset, physically connect your headset to the phone and activate the headset mode for use. For more information on physically connecting a headset, refer to [Phone Installation](#) on page 14.

If you want to use a wireless headset, insert the Bluetooth USB dongle into the USB port on the back of the phone. For more information on using a Bluetooth headset, refer to [Bluetooth](#) on page 75.

This section provides an introduction to wired headset use.

### Note

If both a Bluetooth headset and a wired headset are connected, only the Bluetooth headset can be used.

## Headset Mode Activation/Deactivation

### To activate the headset mode:

1. Press  on the phone.

The HEADSET key LED illuminates solid green when the headset mode is activated.

When you press the **Answer** soft key to answer an incoming call, the call is connected to your headset automatically. For more information on using the headset to answer a call, refer to [Answering Calls](#) on page 95.

With the handset on-hook, enter the desired number and press the **Send** soft key, the phone will then place a call using the headset automatically. For more information on using the headset to place a call, refer to [Placing Calls](#) on page 93.

### To deactivate the headset mode:

1. Press  again on the phone.

The HEADSET key LED goes out when the headset mode is deactivated.

## Headset Prior

You can use headset in priority when headset prior feature is enabled. This feature is especially useful for permanent or full-time headset users.

To enable headset prior via web user interface:

1. Click on **Features->General Information**.
2. Select **Enabled** from the pull-down list of **Headset Prior**.

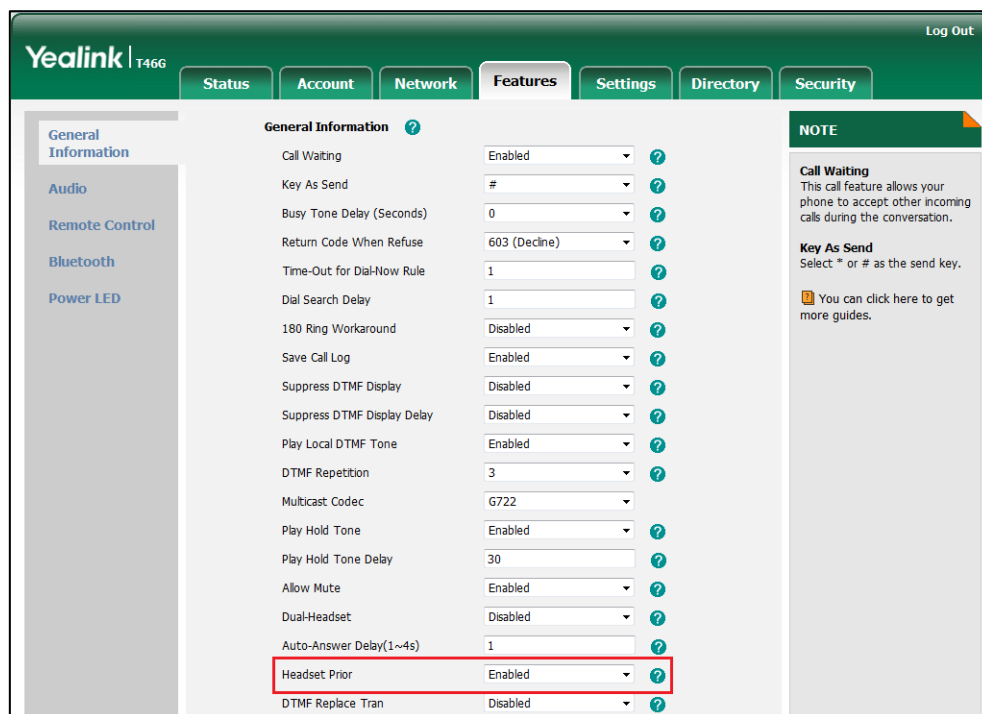

3. Click **Confirm** to accept the change.

To use headset prior, you should activate the headset mode in advance:

1. Physically connect the headset.
2. Press  to activate the headset mode.

#### Note

If headset prior is enabled, the headset mode will not be deactivated until you press the **HEADSET** key again.

If headset prior is disabled, the headset mode can be deactivated by pressing the speakerphone key or the **HEADSET** key.

Headset prior is configurable via web user interface only.

## Dual Headset

You can use two headsets when dual headset feature is enabled. To use this feature, you must physically connect headsets to the headset jack and handset jack respectively. Once the phone connects to a call, the headset connected to the headset jack will have full-duplex capabilities, while the one connected to the handset jack will only be able to listen.

To enable dual headset via web user interface:

1. Click on **Features->General Information**.
2. Select **Enabled** from the pull-down list of **Dual-Headset**.

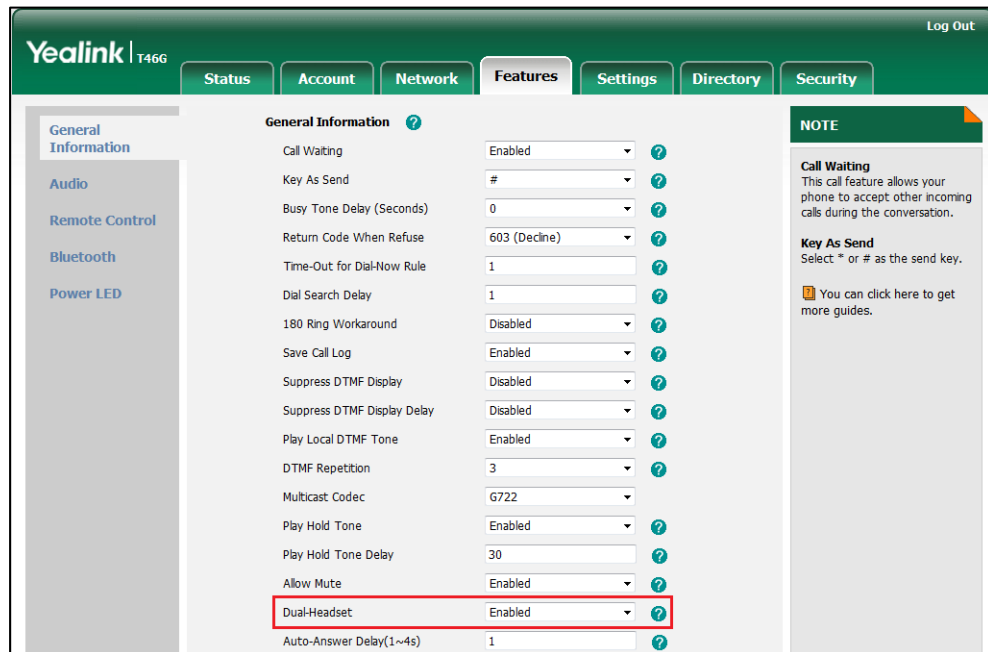

3. Click **Confirm** to accept the change.

**Note** Dual headset is configurable via web user interface only.

## Bluetooth

The SIP-T46G IP phone supports Bluetooth. Bluetooth enables low-bandwidth wireless connections within a range of 10 meters (32 feet). The best performance is in the 1 to 2 meter (3 to 6 feet) range.

You can activate/deactivate the Bluetooth mode on the phone, and then pair and connect the Bluetooth headset with your phone. Only one headset can be connected at a time. You can also disconnect and delete your Bluetooth headset from the phone.

**Note** Ensure that the Bluetooth USB dongle is properly connected to the USB port on the back of the phone. For more information, refer to [Phone Installation](#) on page 14.

## Enabling the Bluetooth Mode

To enable the Bluetooth mode via phone user interface:

1. Press **...** ->**Basic**->**Bluetooth**.
2. Press **◀** or **▶** , or the **Switch** soft key to select **On** from the **Bluetooth** field.

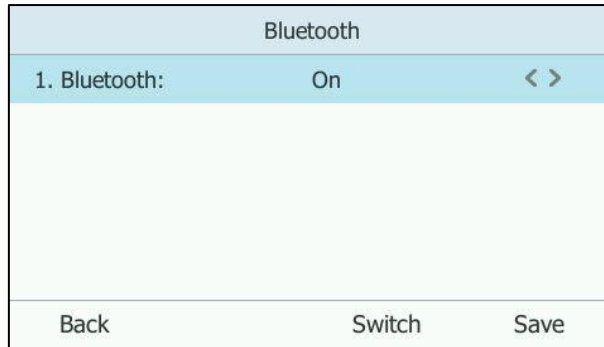

3. Press the **Save** soft key to accept the change.

The LCD screen displays the Bluetooth icon .

Bluetooth mode is configurable via web user interface at the path **Features->Bluetooth**.

## Pairing and Connecting the Bluetooth Headset

Before you pair a Bluetooth headset, check the indicator on the Bluetooth headset to make sure that the Bluetooth headset is discoverable. For more information, refer to the documentation from the Bluetooth headset manufacturer.

When you insert Bluetooth USB dongle BT40 into the USB port on the back of the phone, the LCD screen prompts "Adapter has been added, scanning the Bluetooth devices right now?". You can press the **OK** soft key to enter the Bluetooth screen. You can activate Bluetooth mode and then scan Bluetooth devices.

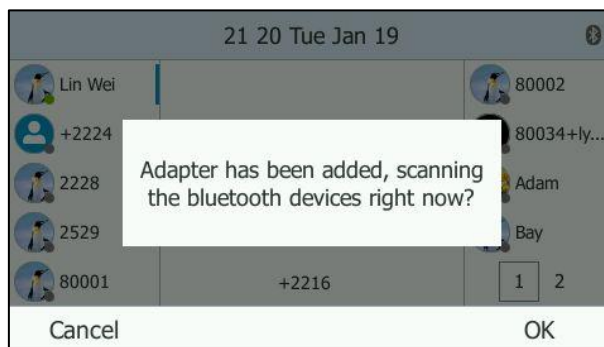

To pair and connect your Bluetooth headset to your phone:

1. Press **...** ->**Basic**->**Bluetooth**.
2. Press the **Scan** soft key to search the Bluetooth devices.

The LCD screen prompts the following message:

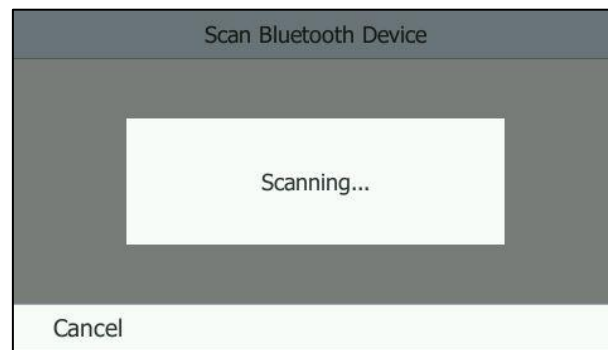

The phone proceeds to scan the local Bluetooth devices. When the phone completes scan, it will display the available Bluetooth devices on the LCD screen.

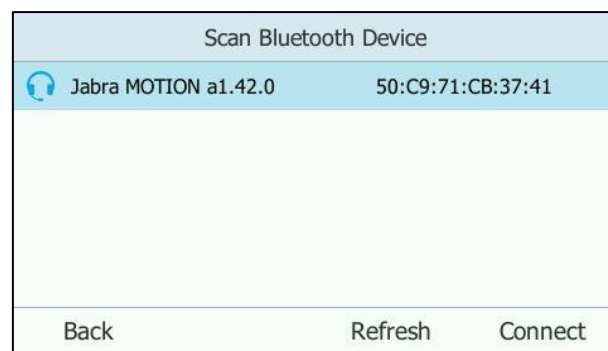

3. Select the desired Bluetooth headset and then press **Connect** soft key.
4. Enter the PIN in the **Password** field.  
The default PIN is "0000" or "1234".

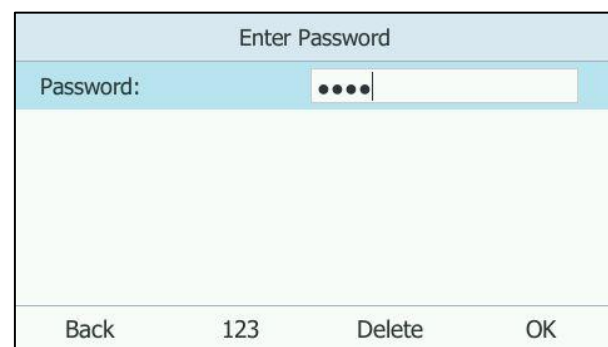

The Bluetooth headset is then automatically connected to your phone.

The Bluetooth icon  appears on the LCD screen.



With the Bluetooth headset paired and connected, you can use the Bluetooth headset to place and answer calls. For more information, refer to the documentation from the Bluetooth headset manufacturer.

**Note** When the phone proceeds to scan the local Bluetooth devices, none is displayed on the LCD screen. You can press **Refresh** soft key to scan the local Bluetooth devices again.

## Viewing the Bluetooth headset information

To view the Bluetooth headset information:

1. Press **...** -> **Basic**-> **Bluetooth**-> **Paired Bluetooth Device**.

The LCD screen displays a list of paired and connected Bluetooth headsets.

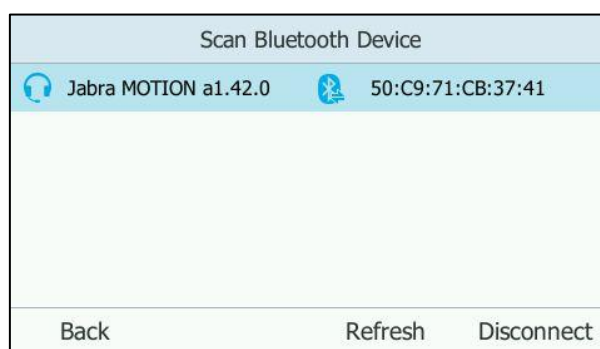

2. Select the desired Bluetooth headset.
3. Press the **Option** soft key, and then select **Detail** from the prompt list to view the Bluetooth headset information:

- **Device Name:** the name of the Bluetooth headset.
- **MAC:** the MAC address of the Bluetooth headset.

Jabra MOTION a1.42.0	
1. Device Name:	Jabra MOTION a1.42.0
2. MAC:	50:C9:71:CB:37:41
Back      abc      Delete      Disconnect	

## Editing the Bluetooth Device Information

To edit the Bluetooth device information via phone user interface:

1. Press **...** -> **Basic**->**Bluetooth**.
2. Press **◀** or **▶**, or the **Switch** soft key to select **On** from the **Bluetooth** field.
3. Press the **Save** soft key to accept the change.
4. Select **Edit My Device Information** and then press the **Enter** soft key.

The LCD screen displays the device name and MAC address. The MAC address cannot be edited.

5. Enter the desired name in the **Device Name** field.

The default device name is "Yealink-T46G".

Edit My Device Information	
1. Device Name:	Yealink-T46G
2. MAC:	00:1A:7D:DA:71:04
Back      abc      Delete      Save	

6. Press the **Save** soft key to accept the change or the **Back** soft key to cancel.

The preconfigured Bluetooth device name will display in scanning list of other device.

## Disconnecting the Bluetooth Headset

To disconnect your Bluetooth headset from your phone:

1. Press **...** ->**Basic**->**Bluetooth**->**Paired Bluetooth Device**.
2. Select the connected Bluetooth headset.

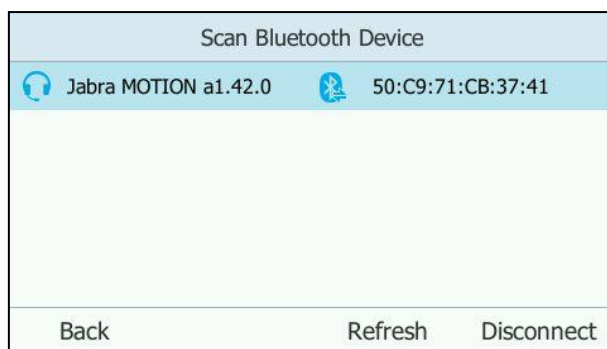

3. Press the **Disconnect** soft key.

The Bluetooth headset is disconnected. To connect it to your phone again, press the **Connect** soft key.



## Deleting the Bluetooth Headset

You can delete your Bluetooth headset from your phone. When you delete the Bluetooth headset, it disappears from the **Paired Bluetooth Device** list. To connect it to your phone again, you need to scan and connect it again.

To delete your Bluetooth headset from your phone:

1. Press **...** ->**Basic**->**Bluetooth**->**Paired Bluetooth Device**.
2. Select the Bluetooth headset you want to delete.
3. Press the **Option** soft key, and then select **Delete** from the prompt list.



The LCD screen prompts the following warning “Delete the selected item?”.



4. Press the **OK** soft key to confirm the deletion or the **Cancel** soft key to cancel.

**Note**

You can also delete all headsets by pressing the **Option** soft key and then select **Delete All**. For more information, refer to the above steps.

If you cannot connect a Bluetooth headset to the phone successfully, we recommend that you delete the Bluetooth headset from the **Paired Bluetooth Device** list (if it exists) before pairing it.

## Disabling the Bluetooth Mode

To disable the Bluetooth mode via phone user interface:

1. Press **...** -> **Basic**-> **Bluetooth**.
2. Press **◀** or **▶**, or the **Switch** soft key to select **Off** from the **Bluetooth** field.

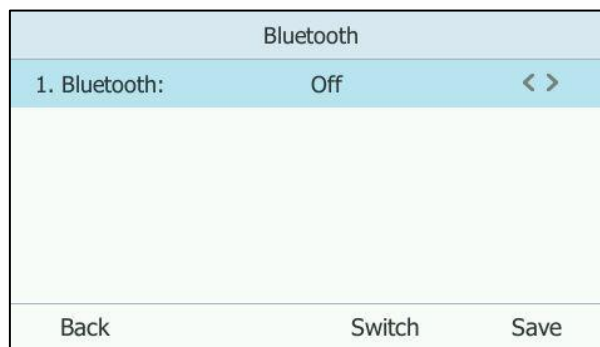

3. Press the **Save** soft key to accept the change.

The Bluetooth icon  disappears from the phone.

If a Bluetooth headset is paired and connected, and then you deactivate the Bluetooth mode, it will disappear from the **Bluetooth Devices** list. The Bluetooth headset won't be connected anymore, but it will still be paired. When you activate the Bluetooth mode again, the Bluetooth headset will be connected automatically if Auto Connection feature is enabled.

Bluetooth mode is configurable via web user interface at the path **Features->Bluetooth**.

## E911

E911 (Enhanced 911) is a location technology that enables the called party to identify the geographical location of the calling party. For example, if a caller makes an emergency call to E911, the feature extracts the caller's information for the police department to immediately identify the caller's location.

### E911 Location Tip

The system administrator configures geographical location for users on the Skype for Business Server. After user signs in, the geographical location is downloaded to the phone. If geographical location is not provisioned by the server, an E911 location tip will appear to prompt the user that the location of the phone is not set.

#### To configure E911 location tip via web user interface:

1. Click on **Features->General information**.
2. Select desired value from the pull-down list of **E911 Location Tip**.

Depending on your selection:

- If you select **Enabled**:  
When the location is not set, location notification depends on the configuration on the Skype for Business Server.
- If you select **Disabled**:  
When the location is not set, the LCD screen will not prompt the location notification.

For more information, refer to [Location Notification](#) on page 83.

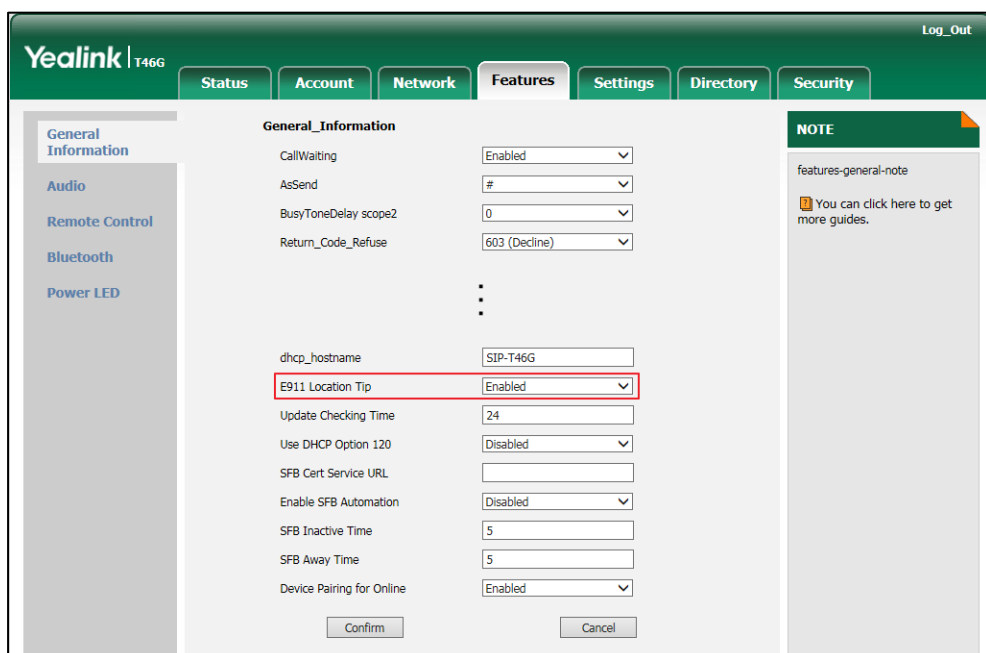

3. Click **Confirm** to accept the change.

**Note**

When the location is set, no matter whether E911 location tip is enabled or disabled, the LCD screen will not prompt the location notification.

E911 location tip feature is configurable via web user interface only.

## Location Notification

When E911 location tip feature is enabled and the location of the phone is not set, the location notification depends on the configuration on the Skype for Business Server.

- a) When the parameter **Location Required** is set to **Yes** on the Skype for Business Server, the **Status** menu will display  icon. The LCD screen is shown as below after login:

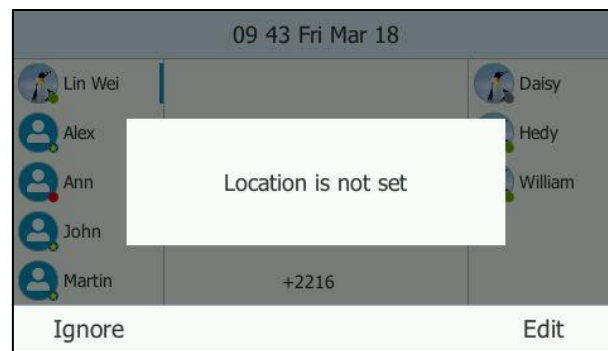

You can do one of the following:

- Press the **Ignore** soft key.  
The phone will return to the idle screen.
- Press the **Edit** soft key.  
The phone will enter the **Location Edit** screen.

- b) When the parameter **Location Required** is set to **Disclaimer** on the Skype for Business Server, the **Status** menu will display  icon. The LCD screen is shown as below after login:

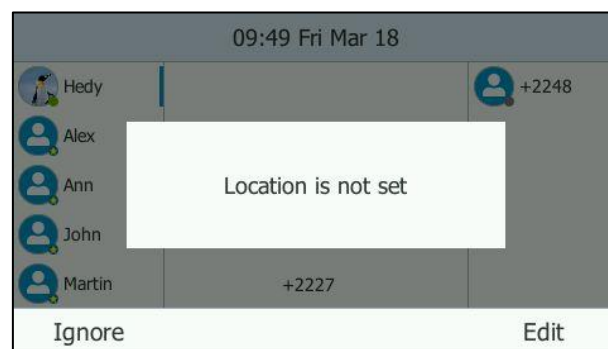

- You can do one of the following:

Press the **Ignore** soft key.

The phone will display the disclaimer configured on the Skype for Business Server.

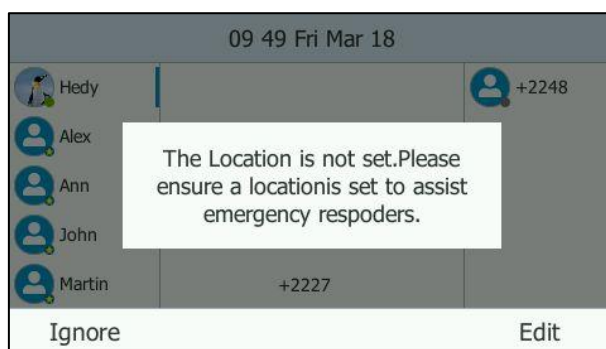

You can press the **Back** soft key to return to the idle screen or press the **Add** soft key to enter the **Location Edit** screen.

- Press the **Edit** soft key.

The phone will enter the **Location Edit** screen.

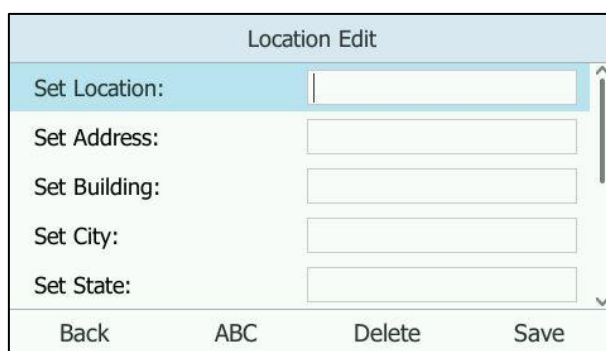

- c) When the parameter **Location Required** is set to **No** on the Skype for Business Server, the **Status** menu will not display  icon. The LCD screen is shown as below after login:

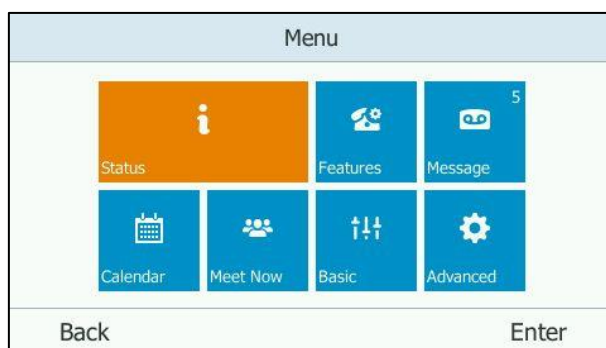

## Adding the Location Information

You can add the location information in one of the two ways:

- Reload the location formation from the Skype for Business Server.
- Add the location formation manually.

### Reloading the Location Information on the Skype for Business Server

The network administrator configures geographical location on the Skype for Business Server for the phone. After the phone signs in or reboots, the geographical location is downloaded automatically. The phone will update the geographical location every 4 hours automatically. If the geographical location configured on the server updates, you can also reload it via phone user interface manually.

**To reload the location information via phone user interface:**

1. Press **...->Basic->Location**.
2. Press the **Reload** soft key to reload the location information from the Skype for Business Server.

Location set on the phone will be covered by location set on the Skype for Business Server.



### Adding the Location Information Manually

If geographical location is not provisioned on the Skype for Business Server, you can add the location information manually via phone user interface.

To add the location information manually via phone user interface:

1. Press **...**->**Basic**->**Location**.
2. Press the **Edit** soft key.

3. Enter the location name in the **Set Location** field.
4. Enter the address name in the **Set Address** field.
5. Enter the building name in the **Set Building** field.
6. Enter the city name in the **Set City** field.
7. Enter the state name in the **Set State** field.
8. Enter the postcode in the **Set Postcode** field.
9. Press **◀** or **▶**, or the **Switch** soft key to select the country from the **Set Country** field.
10. Press the **Save** soft key to accept the change.

Location is configurable via web user interface at the path **Settings**->**Location**.

#### Note

SIP-T46G IP phone has 24 country locations for you to choose. The country names are displayed in alphabetical order.

## Viewing the Location Information

To view the location information via phone user interface:

1. Press **...** ->**Status**->**Location**.

## Emergency Call

You can dial emergency numbers for assistance. Emergency numbers should be configured on the Skype for Business Server in advance.

You can dial an Emergency Dial String number or Emergency Dial String Mask number even if the phone is locked, and keypad is available during an emergency call. With or without the location information will not affect you to dial an emergency call.

When you dial an Emergency Dial String number or Emergency Dial String Mask

number (e.g., 910086), the LCD screen is shown as below:

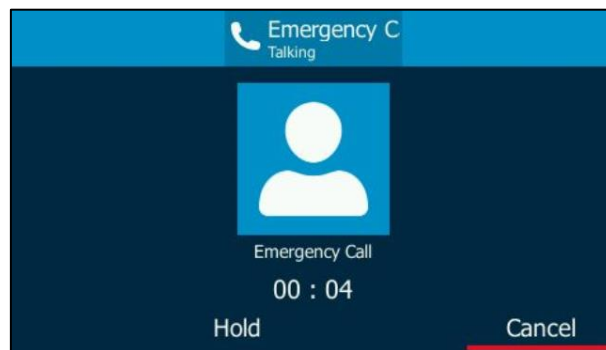

You can cancel or hold the emergency call only.

If call forward feature is configured in advance, the call forward feature will be disabled automatically after calling the emergency number. If the call forward feature is not manually enabled again after the emergency call, it will be enabled automatically after two hours and its settings will also be restored.

If the phone status is DND before dialing an emergency number, then the phone status will change to available after the emergency call. And the phone status will restore to DND status in two hours. Other statuses will not be affected by the emergency call.

#### Note

Emergency Dial String number and Emergency Dial String Mask number are configurable on the Skype for Business Server only. Contact your system administrator for more information.

## Dial-now

You can configure one or more dial-now rules (up to 100) on your phone. When the dialed number matches the dial-now string, the number will be dialed out automatically. For example, a dial-now rule is configured as "1xxx", any entered four-digit string beginning with 1 will then be dialed out automatically on the phone.

Basic expression syntaxes you need to know:

Syntax	Description
.	The dot "." can be used as a placeholder or multiple placeholders for any character. Example: "12." would match "123", "1234", "12345", "12abc", etc.
x	An "x" can be used as a placeholder for any character. Example: "12x" would match "121", "122", "123", "12a", etc.
-	Numeric ranges are allowed within the brackets: Digit "-" Digit. Example: "[5-7]" would match the number "5", "6" or "7".
[]	The square brackets "[]" can be used as a placeholder for a single

Syntax	Description
	character which matches any of a set of characters. Example: "91[5-7]1234" would match "9151234", "9161234", "9171234".
()	The parentheses "( )" can be used to group together patterns, for instance, to logically combine two or more patterns. Example: "([1-9])([2-7])3" would match "923", "153", "773", etc.
\$	The "\$" followed by the sequence number of a parenthesis means the characters placed in the parenthesis. The sequence number stands for the corresponding parenthesis. Example: A replace rule configuration, Prefix: "001(xxx)45(xx)", Replace: "9001\$145\$2". When you dial out "0012354599" on your phone, the IP phone will replace the number with "90012354599". "\$1" means 3 digits in the first parenthesis, that is, "235". "\$2" means 2 digits in the second parenthesis, that is, "99".

**To add a dial-now rule via web user interface:**

1. Click on **Settings->Dial Plan**.
2. Enter the desired value (e.g., 1xxx) in the **Rule** field.

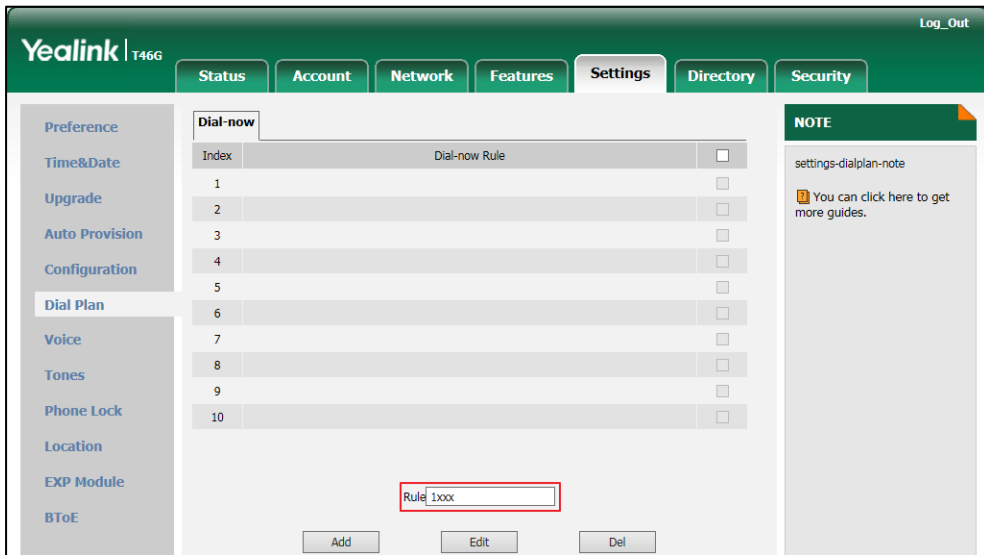

3. Click **Add** to add the dial-now rule.  
For example: when you enter the number "1234" using the keypad, the phone will dial out "1234" automatically without pressing any key.

**Note** Dial-now rule is configurable via web user interface only.

**Delay Time for Dial-Now Rule**

You can configure the delay time for dial-now rules. That is, you can configure your phone to automatically dial out the phone number which matches a dial-now rule, after



the designated delay time.

To configure the delay time for dial-now rule via web user interface:

1. Click on **Features->General Information**.
2. Enter the time between 1 and 14 (seconds) in the **Time-Out for Dial-Now Rule** field.

General Information	
Call Waiting	Enabled
Call Waiting On Code	
Call Waiting Off Code	
Key As Send	#
Reserve # in User Name	Enabled
Busy Tone Delay (Seconds)	0
Return Code When Refuse	486 (Busy Here)
Return Code When DND	480 (Temporarily Unavail)
Feature Key Synchronization	Disabled
<b>Time-Out for Dial-Now Rule</b>	<b>1</b>
RFC 2543 Hold	Disabled
Use Outbound Proxy In Dialog	Enabled
180 Ring Workaround	Enabled
Save Call Log	Enabled

**NOTE**

**Call Waiting**  
It allows IP phones to receive a new incoming call when there is already an active call.

**Auto Redial**  
It allows IP phones to automatically redial a busy number after the first attempt.

**Key As Send**  
Assigns "\*" or "\*" as the send key.

**Hotline**  
IP phone will automatically dial out the hotline number when lifting the handset, pressing the speakerphone key or the line key.

**Call Completion**  
It allows users to monitor the busy party and establish a call when the busy party becomes available to receive a call.

3. Click **Confirm** to accept the change.

For example: when you enter the number "1234" using the keypad, the phone will dial out "1234" automatically after 1 second without pressing any key.

**Note** Delay time for dial-now rule is configurable via web user interface only.

## Live Dialpad

You can enable live dialpad feature on the SIP-T46G IP phone, which enables the IP phone to automatically dial out a phone number without pressing the send key. You can also configure a delay, and then the phone will dial out the phone number automatically after the designated period of time. The delay time is configurable on the Skype for Business Server only.

To enable live dialpad via web user interface:

1. Click on **Settings->Preference**.
2. Select **Enabled** from the pull-down list of **Live Dialpad**.

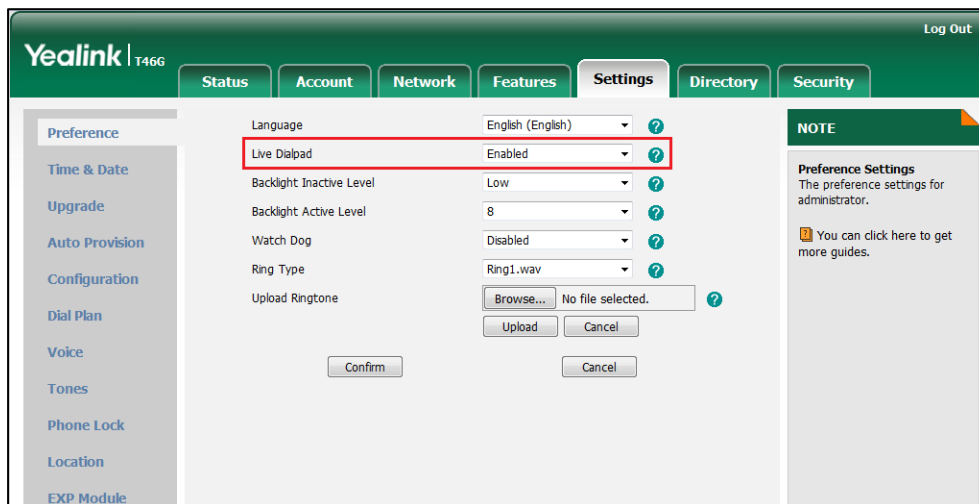

3. Click **Confirm** to accept the change.

**Note** Live dialpad is configurable via web user interface only.

## Privacy Mode

Privacy mode allows you to restrict your presence information, so that it is visible only to the contacts in your Skype for Business directory.

When the privacy mode is disabled on the Skype for Business Server, you can see the following two options available on the phone/Skype for Business client:

- **Everyone Can See My Status Regardless Of System Settings/I want everyone to be able to see my presence regardless of system settings (override default settings):** Everyone in my Microsoft Active Directory Domain can see my presence regardless of system settings.
- **Only Contacts Can See My Status If System Setting/I want the system administrator to decide:** Currently everyone can see my presence but this could be change in the future.

When the privacy mode is enabled on the Skype for Business Server, you can see the following two options available on the phone or Skype for Business client:

- **Everyone can see my status/I want everyone to be able to see my presence:** Everyone in my Microsoft Active Directory Domain can see my presence.
- **Only contacts can see my status/I only want people in Contacts to see my presence:** Only the contacts in my Skype for Business directory can see my presence. The other contacts in my Microsoft Active Directory Domain see my presence is offline.

## Modifying the Privacy Mode from the Phone

To modify the privacy mode from the phone:

1. Press **Menu->Features->Private Mode**.
2. Do one of the following:
  - a) If the privacy mode is disabled on the Skype for Business Server, the phone LCD screen displays as below:

Private Mode	
<input type="radio"/>	Everyone Can See My Status Regardless Of Syste...
<input checked="" type="radio"/>	Only Contacts Can See My Status If System Setting
Back	Save

Mark the desired radio box.

- b) If the privacy mode is enabled on the Skype for Business Server, the phone LCD screen displays as below:

Private Mode	
<input type="radio"/>	Everyone can see my status
<input checked="" type="radio"/>	Only contacts can see my status
Back	Save

Mark the desired radio box.

3. Press the **Save** soft key to accept the change or the **Back** soft key to cancel.

## Modifying the Privacy Mode from the Skype for Business Client

To modify the privacy mode from the Skype for Business client:

1. Open Skype for Business client.
2. Click  .
3. In the **Skype for Business - Options** dialog box, click **Status**.
4. Do one of the following:

a) If the privacy mode is disabled on the Skype for Business Server:

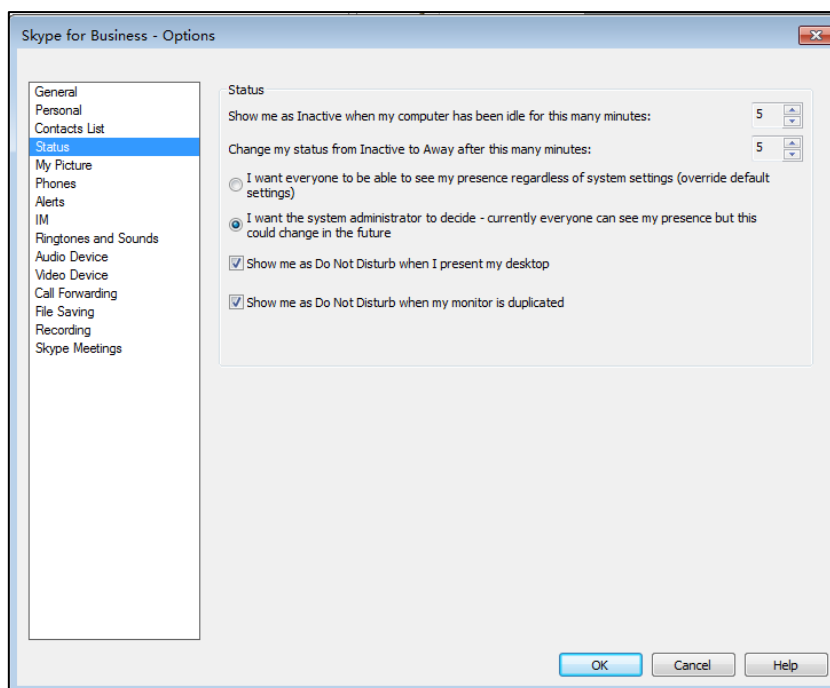

Mark the desired radio box.

b) If the privacy mode is enabled on the Skype for Business Server:

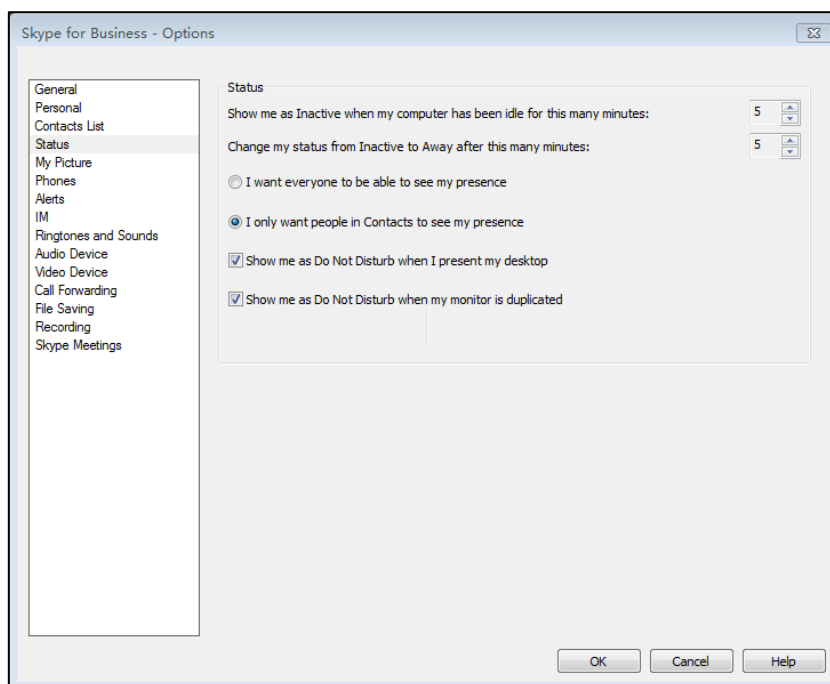

Mark the desired radio box.

5. Click **OK** to accept the change.

## Basic Call Features

---

The SIP-T46G IP phone is designed to be easily used like a regular phone on a public switched telephone network (PSTN). You can place calls, answer calls, transfer a call to someone else, or conduct a Skype for Business conference call. You can also use calendar, response groups or boss-admin Skype for Business feature.

This chapter provides basic operating instructions for the SIP-T46G IP phone. Topics include:

- [Placing Calls](#)
- [Answering Calls](#)
- [Ending Calls](#)
- [Redialing Numbers](#)
- [Auto Answer](#)
- [Call Waiting](#)
- [Call Mute](#)
- [Call Hold/Resume](#)
- [Calendar](#)
- [Call Forward](#)
- [Response Groups](#)
- [Boss-Admin Feature](#)
- [Inbound Private Line](#)
- [Call Transfer](#)
- [Group Call Pickup](#)
- [Skype for Business Conference](#)
- [Call Park](#)
- [Voice Mail](#)
- [Multicast Paging](#)
- [Branch Office Resiliency](#)

If you require additional information or assistance with your new phone, contact your system administrator.

## Placing Calls

You can place a call in three ways using your SIP-T46G IP phone:

- Using the handset
- Using the speakerphone
- Using the headset

You can also dial the number first, and then choose the way you want to speak to the other party.



You can search for the contacts and then dial from the result list. For more information, refer to [Searching for Contacts](#) on page 69.

During a call, you can alternate between Speakerphone, Headset, and Handset modes by pressing the Speakerphone key, the HEADSET key, or picking up the handset.

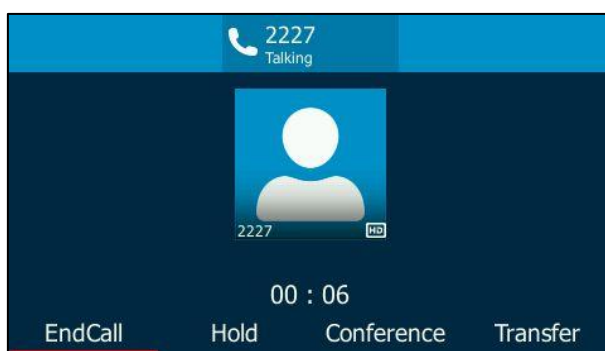
The call duration of the call, the talking mode and the avatar of the contact are visible on the touch screen. In the figure below, the call to “2227” has lasted 6 seconds.









#### To place a call using the handset:

1. Pick up the handset.
2. Enter the desired number using the phone keypad.
3. Press  ,  , or the **Send** soft key.

The # key is configured as a send key by default. You can also set the \* key as the send key, or set neither. For more information, refer to the [Key as Send](#) on page 45.

#### To place a call using the hands-free speakerphone mode:

Do one of the following:

- With the handset on-hook, press  or the line key to obtain a dial tone.  
Enter the desired number using the keypad.  
Press  ,  or the **Send** soft key.
- With the handset on-hook, enter the desired number using the keypad.  
Press  ,  ,  or the **Send** soft key.



#### To place a call using the headset:

Do one of the following:

- With the optional headset connected, press  to activate the headset mode.



Press the line key to obtain a dial tone.

Enter the desired number using the keypad.

Press  ,  , or the **Send** soft key.

- With the optional headset connected, press  to activate the headset mode.

Enter the desired number using the keypad.

Press  ,  , or the **Send** soft key.





### Note



To permanently use the headset mode, refer to [Headset Prior](#) on page 73.

The SIP-T46G IP phone can handle multiple calls at a time. However, only one active call (the call that has audio associated with it) can be in progress at any time. The SIP-T46G IP phone can handle a maximum of 50 calls at one time.

### To place multiple calls:

You can have more than one call on your SIP-T46G IP phone. To place a new call during an active call, do one of the following:

- Press the line key. The active call is placed on hold.  
Enter the desired number using the keypad.  
Press  ,  , or the **Send** soft key.
- Press  or the **Hold** soft key to place the original call on hold.  
Press the **NewCall** soft key.  
Enter the desired number using the keypad.  
Press  ,  , or the **Send** soft key.

You can press  or  to switch between calls, and then press the **Resume** soft key to retrieve the desired call.

## Answering Calls

When you are not in another call, you can answer a call in three ways:

- Using the handset
- Using the speakerphone
- Using the headset

### Note

You can ignore incoming calls by pressing the **Reject** soft key or the **Silence** soft key, or pressing  . You can also change your status to Do Not Disturb and then the phone will ignore all incoming calls to your phone. For more information, refer to [Changing Presence Status](#) on page 25.

You can forward incoming calls to someone else by pressing the **FWD** soft key, or to voice mail by pressing the **FWD VM** soft key. For more information, refer to [Call Forward](#) on page 112.

### Answering When Not in Another Call

Call duration and destination will always appear on the LCD screen for the active call.

#### To answer a call using the handset:

1. Pick up the handset.

#### To answer a call using the hands-free speakerphone mode:

Do one of the following:

- Press  .
- With the handset on-hook and the headset mode deactivated, press the **Answer** soft key.
- With the handset on-hook and the headset mode deactivated, press the line key (the line key LED flashes green).

#### To answer a call using the headset:

Do one of the following:

- Press  .

With the headset mode activated, press the **Answer** soft key.

### Answering When in Another Call

If you have an active call, and an incoming call arrives on the phone:

- Press the **Answer** soft key.

The incoming call is answered and the original call is placed on hold.

- Press  to access the new call.





Press  or the **Answer** soft key.

The incoming call is answered and the original call is placed on hold.



## Ending Calls

#### To end a call:

Do one of the following:

- If you are using the handset, press  or the **EndCall** soft key or hang up the handset.
- If you are using the headset, press  or the **EndCall** soft key.
- If you are using the speakerphone, press  or  , or the **EndCall** soft key.

#### Note

When a call is placed on hold, you cannot press  to end it. You should press the **Resume** soft key to resume the call, and then press  to end it.







## Redialing Numbers

To redial the last dialed number from your phone:

1. Press  twice.  
A call to your last dialed number is attempted.



To redial a previously dialed number from your phone:

1. Press  when the phone is idle.
2. Press  or  to select the desired entry from the placed calls list.
3. Press  or the **Call** soft key.

## Auto Answer

You can use auto answer feature to automatically answer an incoming call.

To configure auto answer via phone user interface:

1. Press **...** -> **Features**-> **Auto Answer**.
2. Select the desired line and then press the **Enter** soft key.
3. Press  or  , or the **Switch** soft key to select **Enabled** from the **Auto Answer** filed.

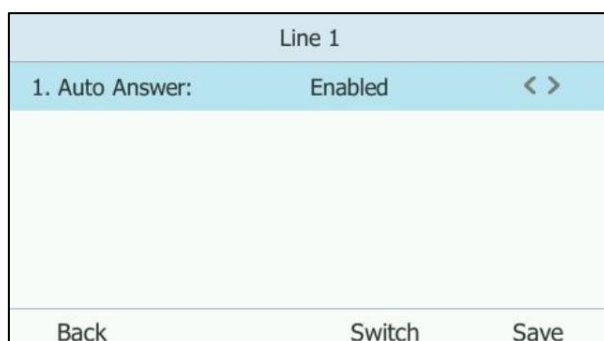

4. Press the **Save** soft key to accept the change or the **Back** soft key to cancel.

The **AA** icon appears on the LCD screen.

Auto answer is configurable via web user interface at the path **Account->Basic->Auto Answer**.

### Note

Auto answer is only applicable when there is no other call in progress on the phone.

## Call Waiting

You can enable or disable call waiting on the phone. If call waiting is enabled, you can

receive another call while there is already an active call on the phone. Otherwise, another incoming call is automatically rejected by the phone with a busy message when there is an active call on the phone. You can also enable or disable the phone to play a warning tone when receiving another call.

**To configure call waiting via phone user interface:**

1. Press **...**->**Features**>**Call Waiting**.
2. Press **◀** or **▶**, or the **Switch** soft key to select **Enabled** from the **Call Waiting** field.

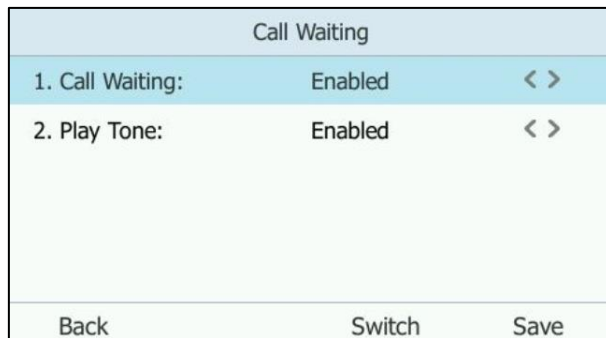

3. Press **◀** or **▶**, or the **Switch** soft key to select **Enabled** from the **Play Tone** field.
4. Press the **Save** soft key to accept the change or the **Back** soft key to cancel.

**To use the call waiting:**

1. When the phone receives an incoming call during a call, press **▶** to see the incoming call.

The phone LCD screen displays as below:

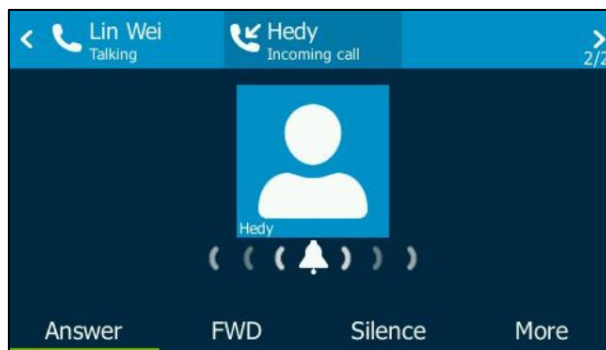

2. Do one of the following:
  - Press the **Answer** soft key to answer the incoming call.  
The original call will be placed on hold.
  - Press the **FWD** soft key to forward the incoming call to another contact.
  - Press the **Silence** soft key to ignore the incoming call.
  - Press **More**->**Reject** to reject the incoming call.

- Press **More->FWD VM** to forward the incoming call to voice mail.

Call waiting is configurable via web user interface at the path **Features->General Information->Call Waiting**.

Call waiting tone is configurable via web user interface at the path **Features->Audio->Call Waiting Tone**.

## Call Mute

You can mute the microphone of the active audio device during an active call, and then the other party cannot hear you. Call mute applies to all modes (Handset, Headset and Speakerphone).

**To mute a call:**

1. Press  during an active call.

The LCD screen indicates that the call is muted. The mute key LED illuminates solid red when the call is muted.



**To un-mute a call:**

1. Press  again to un-mute the call.

## Call Hold/Resume

You can place an active call on hold. Only one active call can be in progress on the phone at any time. Other calls can be made and received while placing the original call on hold. When you place a call on hold, your IP PBX may play music to the other party while waiting.

### To place a call on hold:

1. Press  or press **Hold** during a call.

The LCD screen indicates that the call is on hold. The line key LED slow flashes green.





### Note

The phone will beep softly every 30 seconds to remind you that you still have a call on hold.

### To resume a held call:

1. Press  or the **Resume** soft key.

### Multiple Calls on Hold:

1. Press  or  to switch between the calls, and then press the **Resume** soft key to retrieve the desired call.

If more than two calls are on hold, a numbered prompt appears on the LCD screen, for example "2/4", indicating that this is the first call out of second calls.

## Calendar

Yealink Skype for Business phones integrates with the Microsoft Exchange calendar feature. If your phone is configured to connect to the Microsoft Exchange Server, and the Microsoft® Outlook® application is installed at your site, you can view Skype conference, appointment, meeting and event, or join the Skype conference in your Microsoft Outlook application from your phone.

## Setting up a Skype Conference in Outlook

To set up a Skype conference in outlook:

1. Open Outlook and go to your calendar.



2. Click **HOME->New Skype Meeting**.

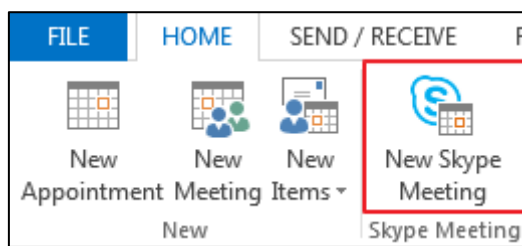

3. In the **To** box, enter the email addresses of your invitees.
4. Enter a subject, location, and then select the start and end time.
5. Enter the content about the Skype conference.
6. Click **Send**.

A Skype conference reminder will display on the phone screen of organizer and invitees 15 minutes before the Skype conference starts.

### Note

If you change the Skype conference content (e.g., location, subject, time) via outlook after you have sent the invitation, the phone will update the Skype conference content.

## Setting up an Appointment in Outlook

To set up an appointment in outlook:

1. Open Outlook and go to your calendar.



2. Click **Home->New Items->More Items->Recurring Appointment**.

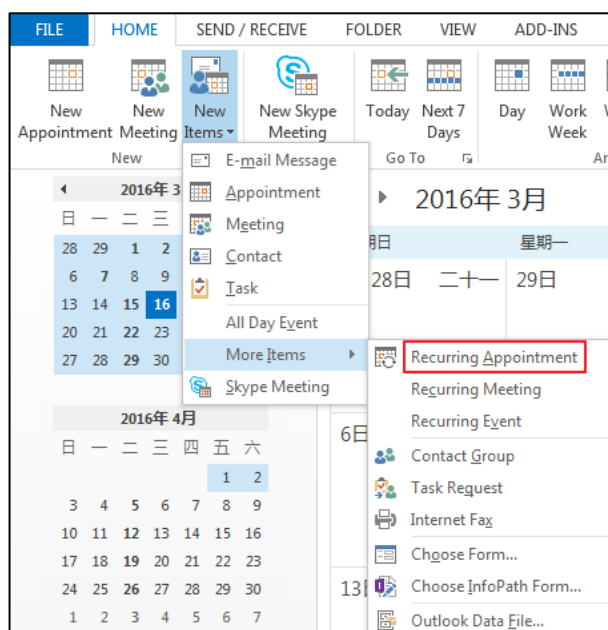

3. Enter the appointment time.
4. Click **OK**.
5. Enter a subject, location and the appointment content.
6. Click **Save & Close**.

An appointment reminder will display on the phone screen 15 minutes before the appointment starts.

## Setting up a Meeting in Outlook

To set up a meeting in outlook:

1. Open Outlook and go to your calendar.

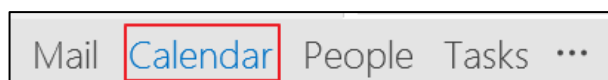

2. Click **Home->New Items->More Items->Recurring Meeting.**

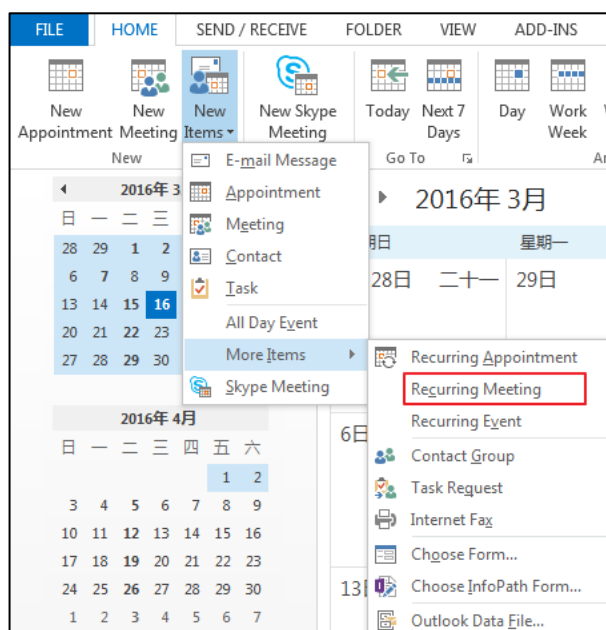

3. Enter the meeting time.
4. Click **OK.**
5. In the **To** box, enter the email addresses of your invitees.
6. Enter a subject, location and the meeting content.
7. Click **Send.**

A meeting reminder will display on the phone screen of organizer and invitees 15 minutes before the meeting starts.

## Setting up an Event in Outlook

To set up an event in outlook:

1. Open Outlook and go to your calendar.



2. Click **Home->New Items->More Items->Recurring Event**.

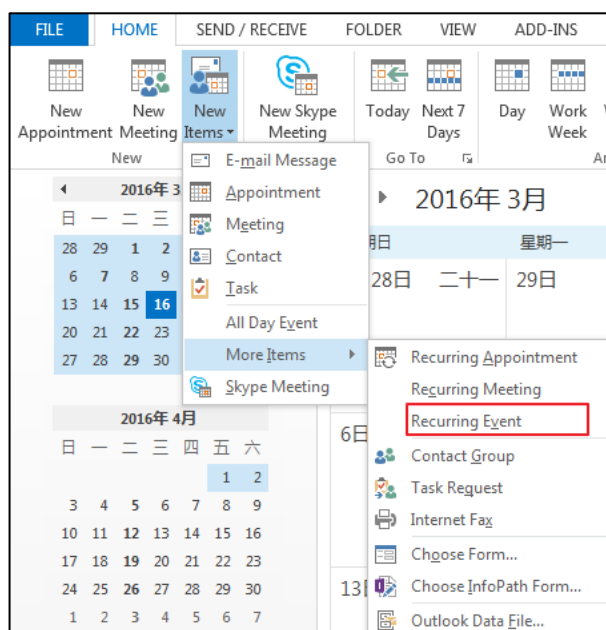

3. Enter the event time.
4. Click **OK**.
5. Enter a subject, location and the event content.
6. Click **Save & Close**.

An event reminder will display on the phone screen 15 minutes before the event starts.

## Using the Calendar

To use the calendar feature on your phone, you must sign into the phone using [User Sign-in](#), [Device Pairing for Online](#) or [BToE Sign-in](#) method. So the phones can display the Microsoft Exchange calendar which gives you quick access to Skype conference, appointment, meeting and event.



## Viewing the Calendar

To view the calendar via phone user interface:

1. Press ...->**Calendar**.

The calendar displays the schedules of today by default.

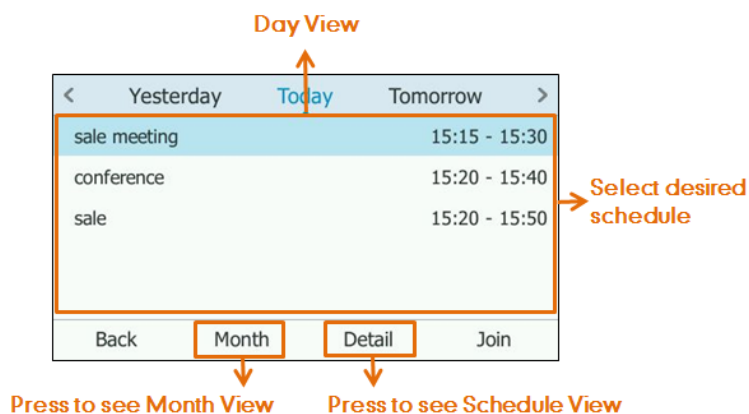

No.	Name	Description
1	Month view	Shows all the days which have schedules in the selected month.
2	Day view	Shows all schedules of the selected day, including the subject, start and end time.
3	Schedule view	Shows the details of the selected schedule, including the subject, participants, organizer, start and end time, location and content.

2. Press the **Back** soft key to return to the pervious screen.

## Navigating Month View

Month view displays all the days which have schedules in the month, including the date and the number of schedules in selected day.

To navigate month view:

1. Press ...->**Calendar**.
2. Press the **Month** soft key to enter the Month view.
3. Do one of the following:
  - Press ◀ to view the previous month.
  - Press ▶ to view the upcoming month.
  - Press ▲ or ▼ to select the desired day.

- Press the **Back** soft key to return to the pervious screen.

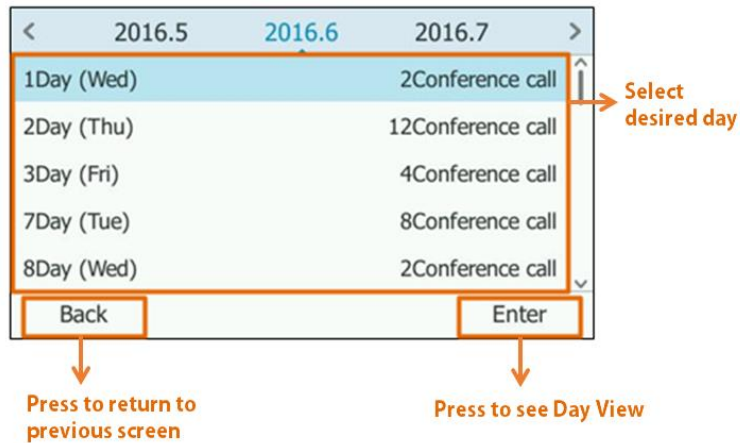

## Navigating Day View

Day view shows all schedules of the selected day, including the subject, start and end time.

**To navigate Day view:**

1. Press ... -> **Calendar**.
2. Do one of the following:
  - Press ◀ to view the schedules of the previous day.
  - Press ▶ to view the schedules of the upcoming day.
  - Press ▲ or ▼ to select a schedule, and then press the **Detail** soft key to view details for a specific schedule.
  - Press the **Back** soft key to return to the pervious screen.

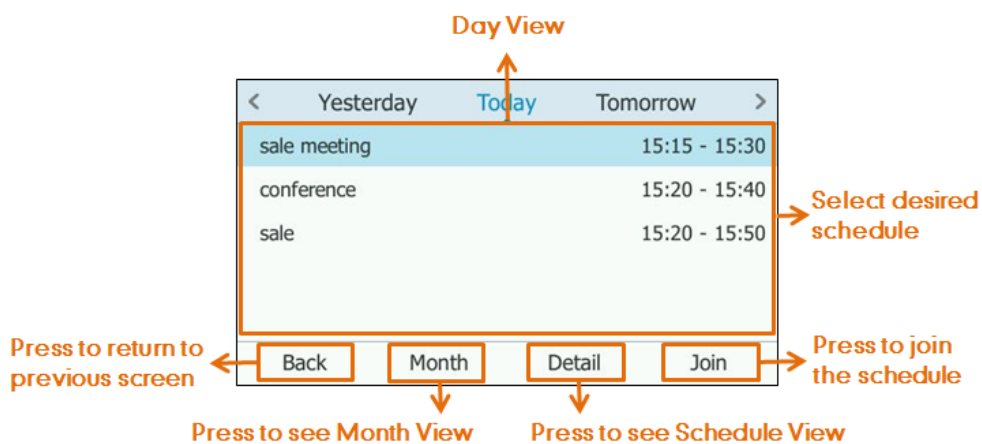

## Navigating Schedule View

Schedule view displays the details of a selected schedule. You can view the schedules' subject, participants, organizer, start and end time, location and content.

**To view schedules via phone user interface:**

1. Press **...**->**Calendar**.
2. Press the **Month** soft key to enter the Month view.
3. Press **◀** or **▶** to select a desired month.
4. Press **▲** or **▼** to select a desired day.

<	2015.11	2015.12	2016.1	>
	1Day (Tue)		7Conference call	
	3Day (Thu)		6Conference call	
	8Day (Tue)		3Conference call	
Back		Enter		

5. Press the **Enter** soft key.
6. Press **▲** or **▼** to select the desired schedule, and then press the **Detail** soft key to view details of a specific schedule.

Detail	
Subject :	Lync Conference
Participants :	Lin Wei;2224-cgc;2529
Organizer :	Lin Wei
Time :	2015/12/8/ 00:00 - 2015/12/9 00:00
Address :	Lync Conference Room1
Back	
Join	

## Working with Schedule Reminders

If you have a schedule, a reminder pop-up is displayed 15 minutes before it starts. The reminder shows the main information of the schedule, including subject and the rest time.

If you receive a reminder of an appointment, meeting or event, you can:

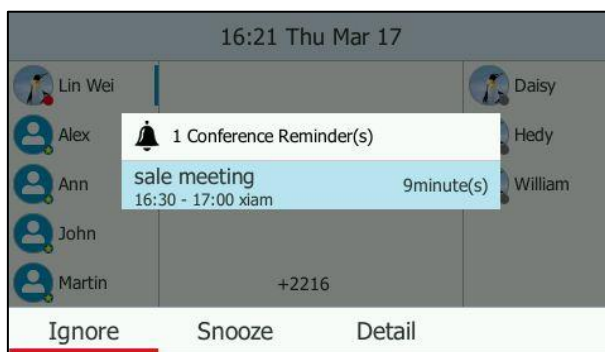

- Press the **Ignore** soft key to permanently remove the reminder from the screen and stop all future reminders for this schedule.
- Press the **Snooze** soft key to temporarily remove the reminder from the screen, until the next schedule reminder. The reminder will appear every 5 minutes before the schedule starts.
- Press the **Detail** soft key to view specific information.

If you receive a reminder of a Skype conference, you can:

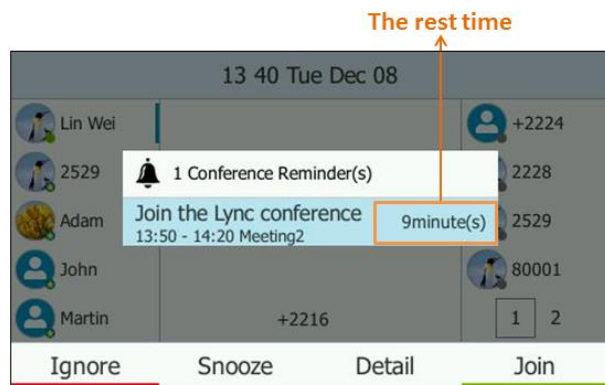

- Press the **Ignore** soft key to permanently remove the reminder from the screen and stop all future reminders for the Skype conference.
- Press the **Snooze** soft key to temporarily remove the reminder from the screen, until the next schedule reminder. The reminder will appear every 5 minutes before the Skype conference starts.
- Press the **Detail** soft key to view specific information about the Skype conference, including the Skype conference's subject, participants, organizer, start and end time, location and content.
- Press the **Join** soft key to join the Skype conference.

**Note**

When receives a Skype conference reminder during a call, you can press the **Join** soft key to join the Skype conference directly. Current call will be held and you can resume it after the Skype conference.

If you do not deal with the reminder when rest time ends, the “immediately” will replace the rest time.

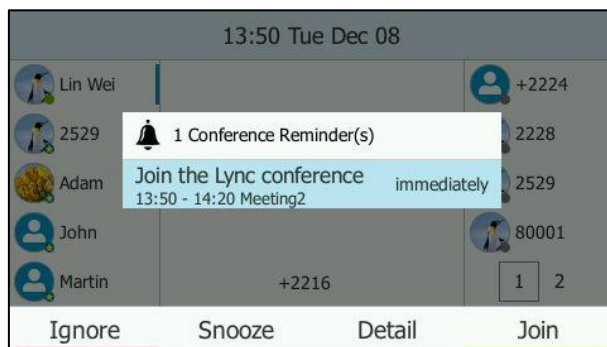

The reminder will show “overdue” when the schedule is overdue.

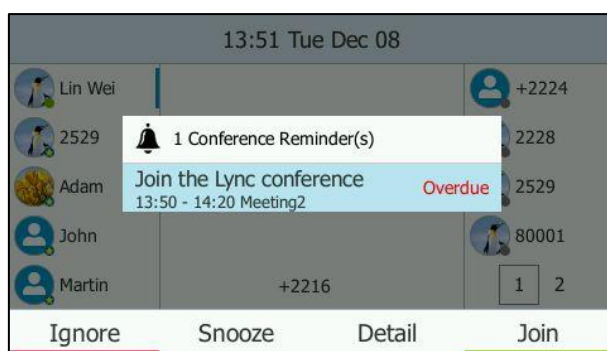

## Joining Skype Conferences from the Calendar

You can join Skype conference from the calendar in following three ways:

- From schedule reminder to join a Skype conference
- From Schedule view to join a Skype conference
- Dialing the conference dial-in number to join a Skype conference

**To join a Skype conference from a schedule reminder:**

Do one of the following:

- Press the **Join** soft key.

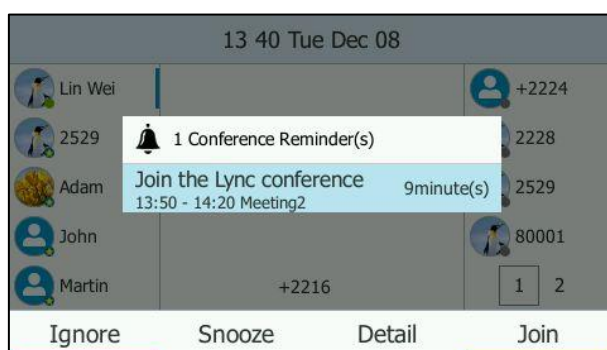

- Press the **Detail** soft key to view specific information about the Skype conference, and then press the **Join** soft key.



**To join a Skype conference from Schedule view:**

1. Press **...** -> **Calendar**.
2. Press the **Month** soft key to enter the Month view.
3. Press **◀** or **▶** to select a desired month.
4. Press **▲** or **▼** to select a desired day.
5. Press **▲** or **▼** to select a desired Skype conference.
6. Do one of the following:
  - Press the **Join** soft key to join the Skype conference.

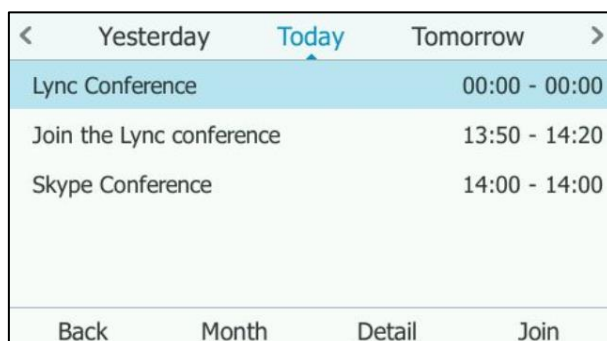

- Press **Detail** soft key to view specific information about the Skype conference, and then press the **Join** soft key.



If you schedule a Skype conference call via Microsoft Outlook Conferencing (Plug-In), dial-in number and Conference ID will be sent to invitees in an email. They can join the Skype conference from phone by dialing dial-in number and Conference ID.

You can also obtain the dial-in number and Conference ID from the phone.

**To obtain the dial-in number and Conference ID form the phone:**

1. Press **Menu->Calendar**.

<	Yesterday	Today	Tomorrow	>
Lync Conference		00:00 - 00:00		
Join the Lync conference		13:50 - 14:20		
Skype Conference		14:00 - 14:00		
Back	Month	Detail	Join	

2. Press the **Month** soft key to enter the Month view
3. Press ◀ or ▶ to select a desired month.
4. Press ▲ or ▼ to select a desired day.
5. Press ▲ or ▼ to select a desired conference.

<	Yesterday	Today	Tomorrow	>
Lync Conference		00:00 - 00:00		
Join the Lync conference		13:50 - 14:20		
Skype Conference		14:00 - 14:00		
Back	Month	Detail	Join	

6. Press the **Detail** soft key to view detail for specific Skype conference.

Detail	
Subject :	Lync Conference
Participants :	Lin Wei;2224-cgc;2529
Organizer :	Lin Wei
Time :	2015/12/8/ 00:00 - 2015/12/9 00:00
Address :	Lync Conference Room1
Back	Join

7. Press ▲ or ▼ to view the dial-in PIN number or Conference ID.

You can also view the dial-in number and Conference ID during a conference call. For more information, refer to [Viewing the Dial-in Number and Conference ID](#) on page 142.

**To join a Skype conference by dialing the conference dial-in number:**

1. Dial the conference dial-in number (e.g., 15915).

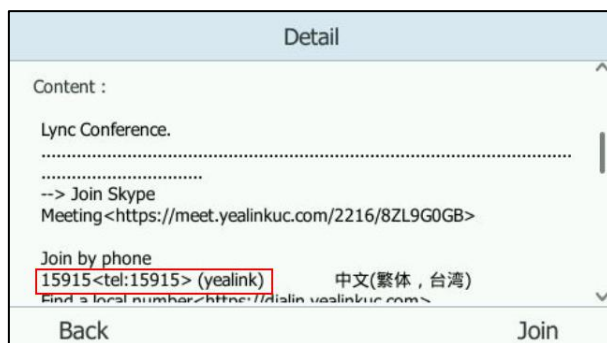

2. Enter the Conference ID (e.g., 5493566), and then press  to join the Skype conference.

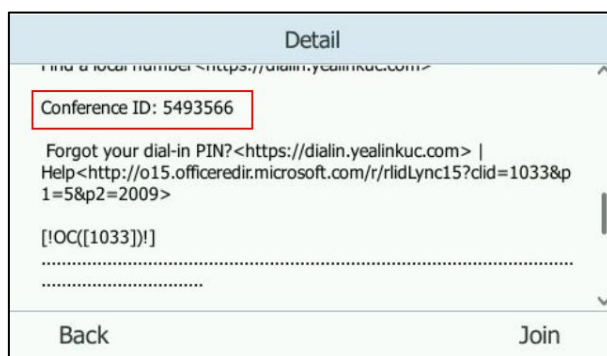

3. More participants can repeat steps 1-2 to join the Skype conference.

For more information on managing the Skype conference participants, refer to the [Managing the Conference Participants](#) on page 143.

## Call Forward

You can configure your phone to forward incoming calls to another party or voice mailbox by the static forwarding. You can also forward calls while your phone is ringing, refer to the [Dynamic Forwarding](#).



## Static Forwarding

### Static Forwarding on SIP-T46G IP Phone

SIP-T46G IP phone supports the following static forwarding ways:

- **Forward to Voice Mail:** incoming calls are forwarded to voice mailbox.
- **Forward Calls to Number:** incoming calls are forwarded to the preset number.
- **Simultaneously Call:** the preset number will ring simultaneously when you receive an incoming call.

To enable call forward:

1. Press **...**->**Features**->**Call Forward**.

You can also press  when the phone is idle.

2. Depending on your selection:

- a) If you select **Forward to Voice Mail**, and press the **Save** soft key.

The prompting message “Forward to Voice Mail” appears on the LCD screen.

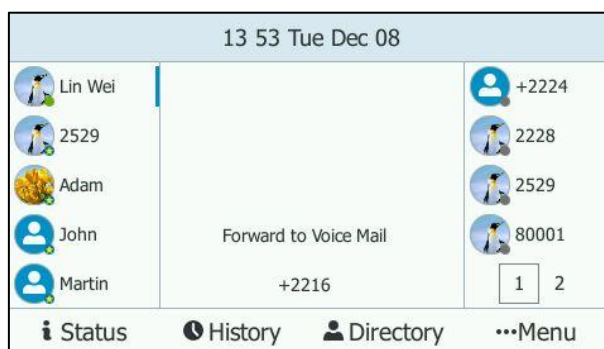

- b) If you select **Forward Calls to Number**, and then press the **Enter** soft key:

- 1) Enter the desired number in the **Forward to** field.
- 2) Press the **Save** soft key to accept the change.

The prompting message “Call Forwarding On” appears on the LCD screen.

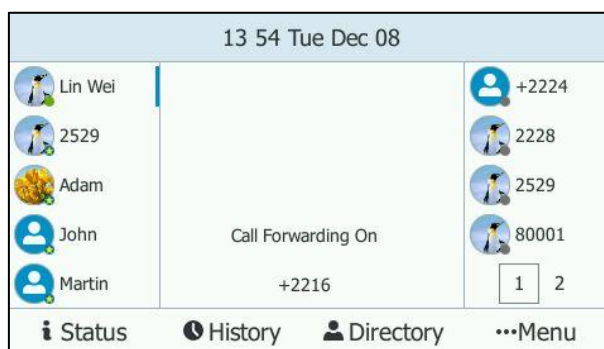

- c) If you select **Simultaneously Call**, and then press the **Enter** soft key:
  - 1) Enter the desired number in the **Simultaneously Ring** field.
  - 2) Press the **Save** soft key to accept the change.

The prompting message “Simultaneously Ring On” appears on the LCD screen.



**To disable call forward:**

1. Press **...->Features->Call Forward**.  
 You can also press  when the phone is idle.
2. Select **Forward Off**.

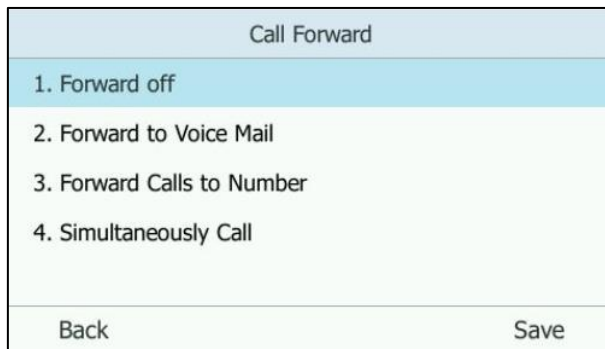

3. Press the **Save** soft key to accept the change.

## Static Forwarding on the Skype for Business client

You can assign static forwarding feature using the Skype for Business client:

- a) **Forward my calls to:**
  - **Voice Mail:** incoming calls are forwarded to voice mailbox.
  - **New Number or Contact:** incoming calls are forwarded to the preset number or contact.
  - **My Delegates:** incoming calls are forwarded to designated delegates.
- b) **Simultaneously ring:**
  - **New Number:** the preset number will ring simultaneously when you receive an

incoming call.

- **My delegates:** the phones of designated delegates will ring simultaneously when you receive an incoming call.
- **My Team-Call Group:** all members in the designated group will ring simultaneously when you receive an incoming call.

**To forward incoming calls immediately without ringing your phone:**

1. In Skype for Business client, click  and then select **Call Forwarding Settings**.

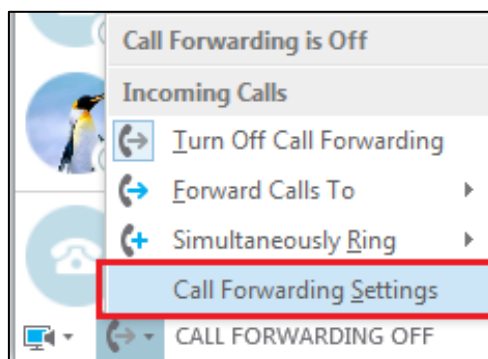

2. Mark the radio box of the **Forward my calls to** field.
3. Select the desired forwarding type from the pull down-list of **Forwarding my calls to**.

Depending on your selection:

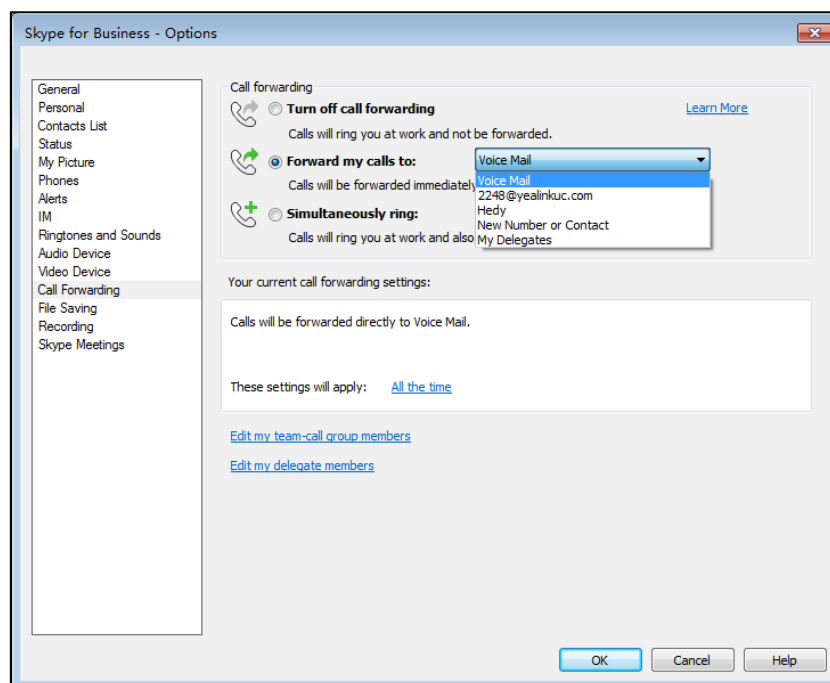

- a) If you select **Voice Mail**:

Incoming calls are forwarded directly to the voice mailbox. The LCD screen is shown as below:

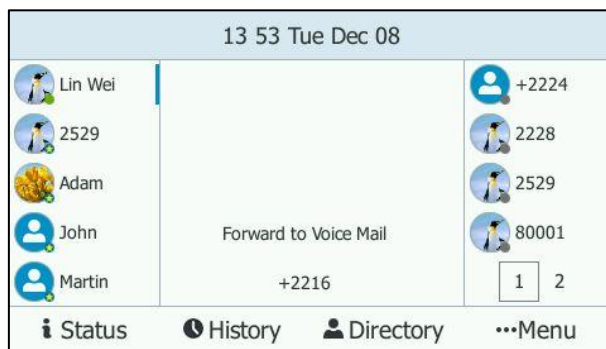

b) If you select **New Number or Contact**:

Select the contact or enter the phone number you want to forward calls to.

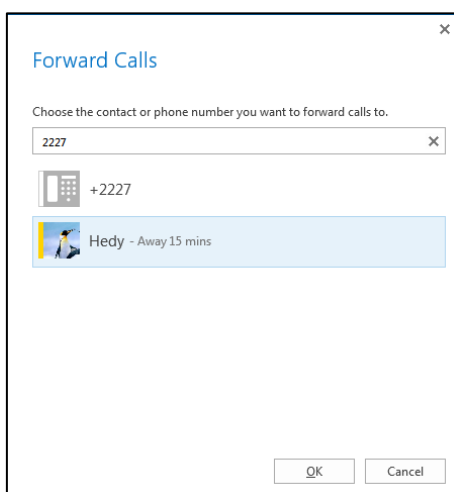

After configuration, incoming calls are forwarded to the preset number or contact.

The LCD screen is shown as below.

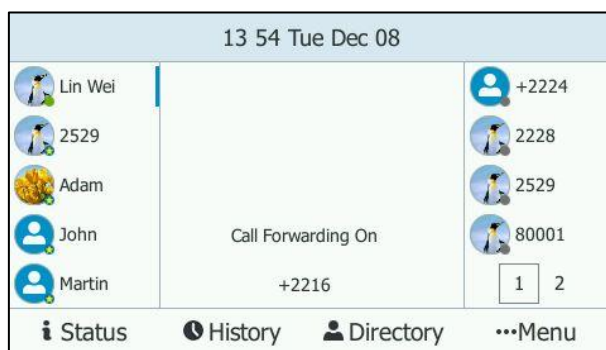

c) If you select **My Delegates**:

Add the delegates you want to forward calls to when you receive an incoming call. The phone of the delegates will ring after the time specified by you.

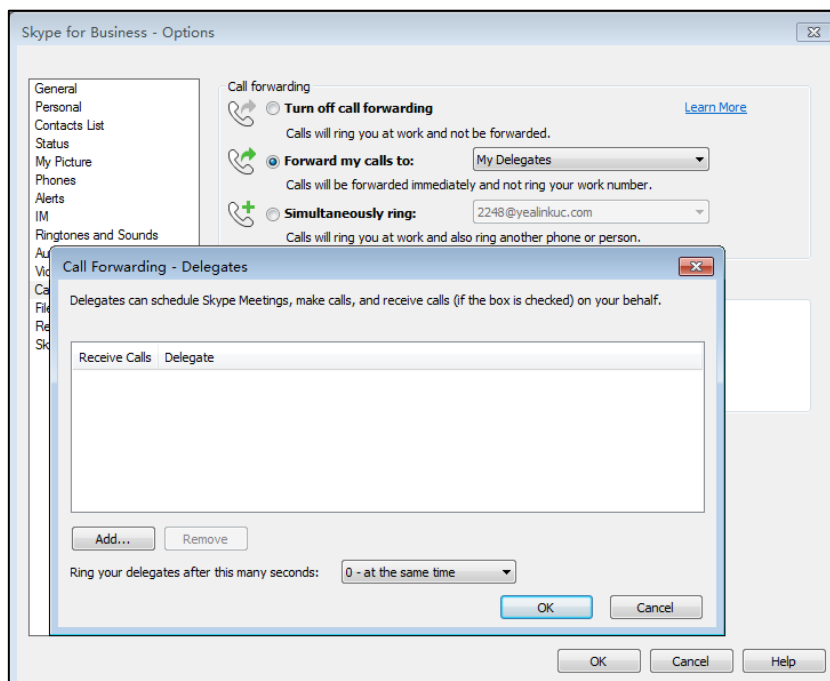

The LCD screen is shown as below:



**To ring other phones simultaneously when your phone is ringing:**

1. In Skype for Business client, click  and then click **Call Forwarding Settings**.
2. Mark the radio box of the **Simultaneously ring** field.

Depending on your selection:

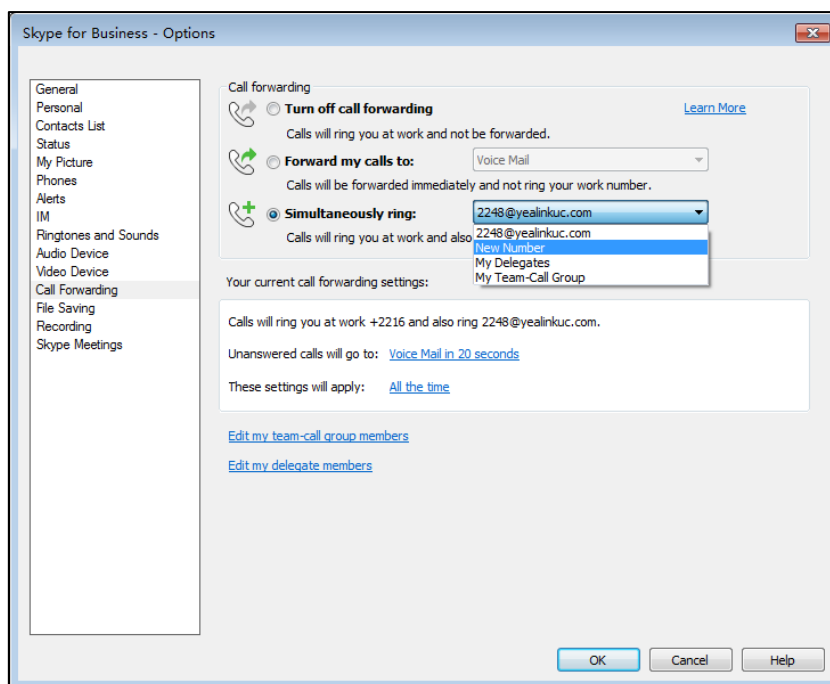

a) If you select **New Number**:

Enter the phone number in the pop-up window, and then click **OK** to accept the change. The number will ring simultaneously when you receive an incoming call.

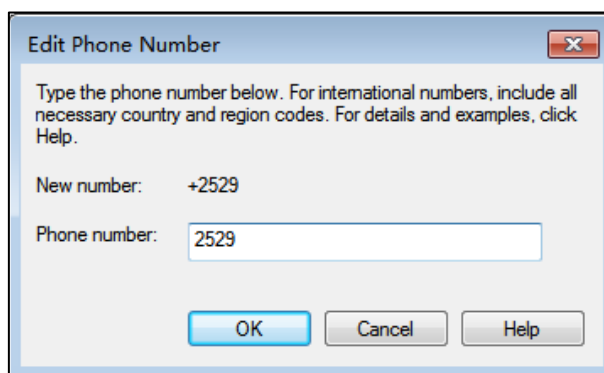

b) If you select **My Delegates**:

Add the delegates you want to ring simultaneously when you receive an incoming call. The phone of the delegates will ring after the time specified by you.

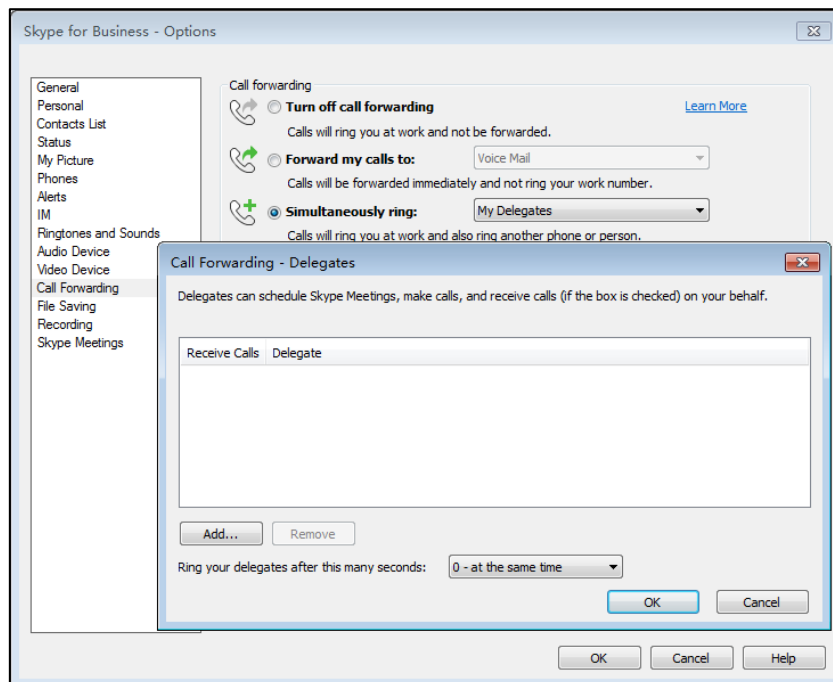
c) If you select **My Team-Call Group**:

Add the contacts in the Team-Call Group. All members in the group will ring simultaneously when you receive an incoming call. The phone of the members in the group will ring after the time specified by you.

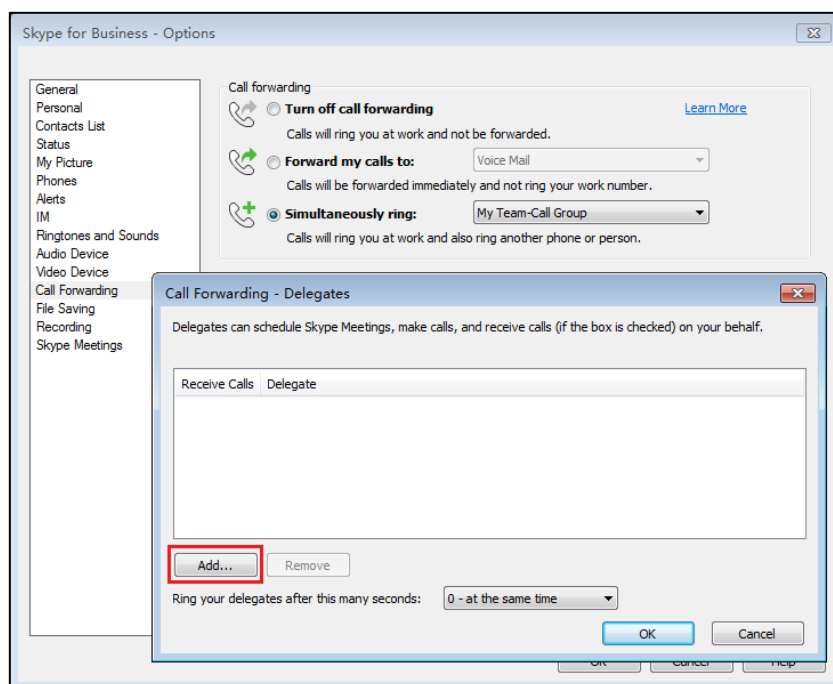

When simultaneously ring feature is enabled, the LCD screen is shown as below:

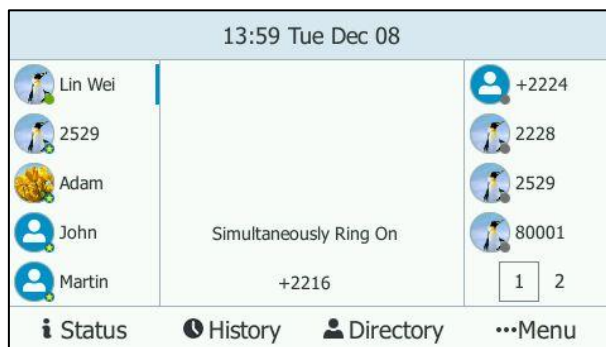

If one member answers the call, other phones will stop ringing.

**To turn off the call forwarding:**

1. In Skype for Business client, click  and then select **Turn Off Call Forwarding**.

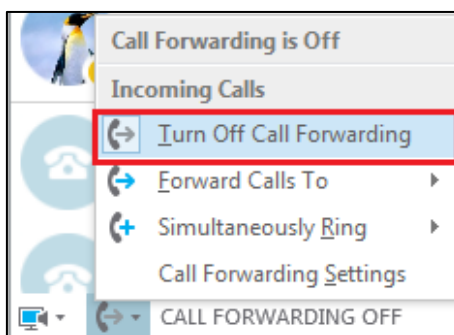

## Dynamic Forwarding

**To forward an incoming call to another party:**

1. Press the **FWD** soft key when the phone is ringing.
2. Do one of the following:
  - Enter the phone number you want to forward the incoming call to, and then press the **Send** soft key.



You can also enter the first few continuous characters of the contact name, phone number or the contact address, and then press the navigation keys to scroll through the result list and select the desired contact.

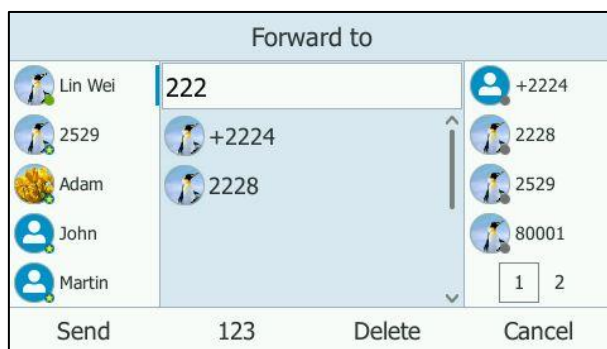

- Press the **Directory** soft key to select the desired contact from the contact list you want to forward the incoming call to, and then press the **FWD** soft key.

The incoming call is forwarded to the entered number or the selected contact.

**To forward an incoming call to voice mail directly:**

1. Press the **More->FWD VM** soft key when the phone is ringing.

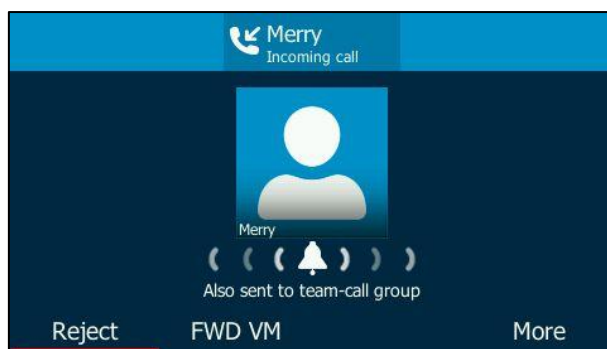

The incoming call will be forwarded to your voice mail directly.

## Forward International

Forward international allows you to forward an incoming call to an international phone number. This feature is enabled by default.

**To disable forward international via phone user interface:**

1. Press **...->Advanced** (default password: admin) **->FWD International**.

- Press ◀ or ▶, or the **Switch** soft key to select **Disabled** to disable the forward international.



- Press the **Save** soft key to accept the change.

Forward international is configurable via web user interface at the path **Features->General Information->Fwd International**.

## Response Groups

If your organization has groups of people who answer and manage certain types of calls, such as for customer service, an internal help desk, or general telephone support for a department, you can deploy the Response Group application to manage these types of calls. The Response Group application routes and queues incoming calls to designated persons, who are known as agents. You can increase the use of telephone support services and reduce the overhead of running these services by using response groups.

When a caller calls a response group, the call is routed to an agent based on a hunt group or the caller's answers to interactive voice response (IVR) questions.

If no agents are available, the call is held in a queue until an agent is available. While in the queue, the caller hears music until an available agent accepts the call. If the queue is full, or if the call times out while in the queue, the caller might hear a message and then is either disconnected or transferred to a different destination, such as a different phone number or voicemail.

The Response Group application uses standard response group routing methods to route the call to the next available agent. The system administrator can configure the routing methods of response group on the Skype for Business Server.

The routing methods of response group are as follows:

- Longest idle** method: The call is routed to the agent who has the longest idle time. If the agent is unavailable, the call goes into the next agent who has the longest idle time until the call is answered.
- Parallel** method: The call is routed to all idle agents. All idle agents are called at the same time for every incoming call.

- **Round robin** method: The call is routed to the agent ordered by agent list circularly. If the agent is unavailable, the call goes into the next agent ordered by agents list circularly until the call is answered or the agent list end.
- **Serial** method: The call is routed to the agent ordered by agents list orderly. If the agent is unavailable, the call goes into the next agent ordered by agents list orderly until the call is answered.
- **Attendant** method: The call is routed to the agents who sign into Skype for Business Server or response group. All agents are called at the same time for every incoming call, regardless of their current presence.

For example, a response group named “yealink” is configured in advance. When a user named “Hedy” calls the response group, the screen of the agent’s phone is shown as below:

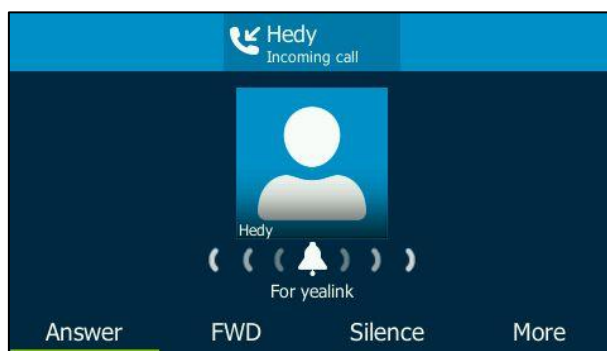

#### Note

Response group should be configured in advance by administrator. Contact your system administrator for more information.

## Boss-Admin Feature

The boss-admin feature, which is also called boss-delegate feature, enables a "boss" phone and delegates' phones to ring simultaneously when a user calls the boss. When one party answers the call, the other phone will stop ringing. A boss can assign delegates and manage calls on the delegate's line.

Delegates can place, answer or hold the call. Delegates can also make a safe transfer to boss's voice mail or call on behalf of the boss's line. The boss can pick up held calls on a delegate's line. What's more, the boss can hold the calls, and the delegate can pick up held calls on the boss's line.

**Boss-Admin Scenario:** The system administrator has configured the phone number 2248 to be the delegate of phone number 2216. For more information on how to assign delegates on the Skype for Business client, refer to [Assigning/Removing Delegates](#) on page 123.

- **Boss:** Lin Wei (phone number: 2216)
- **Delegate:** Merry (phone number: 2248)
- **Other:** Hedy (phone number: 2224)

**Note** Boss-admin feature is configurable via Skype for Business client only.

## Assigning/Removing Delegates

You can assign delegates to your line using the Skype for Business client. However, you cannot assign yourself as a delegate. As a delegate, you can be assigned to multiple bosses' lines.

### To assign delegates using Skype for Business client:

1. Open Skype for Business client.
2. Sign into Skype for Business client as the person who wants to assign a delegate.
3. Click the  , and then click **Call Forwarding Settings**.
4. Mark the radio box of **Simultaneously ring**.
5. Select **My Delegates** from the pull-down list of **Simultaneously ring**.

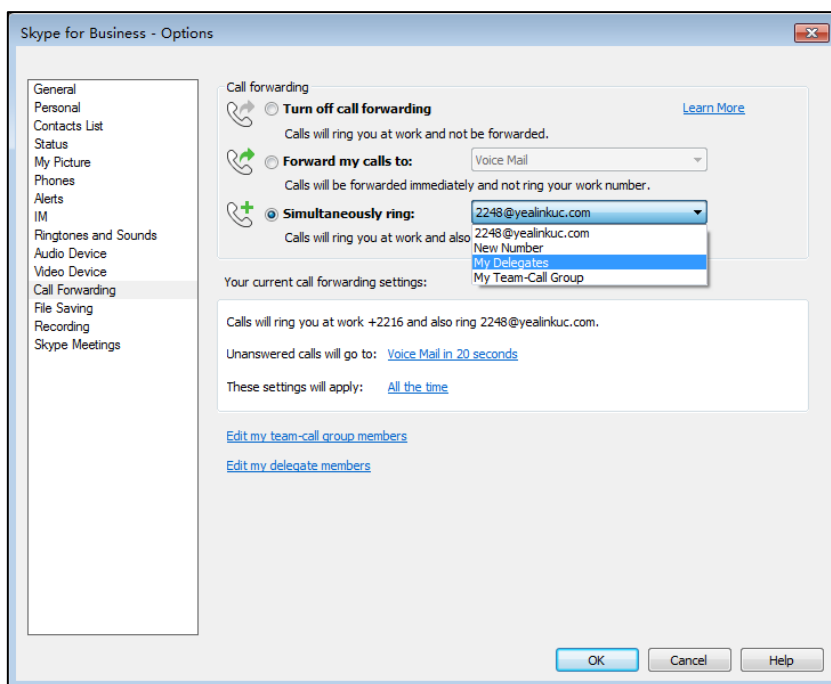

6. In the **Delegates** dialog box, click **Add....** Each delegate must be a Skype for

Business contact.

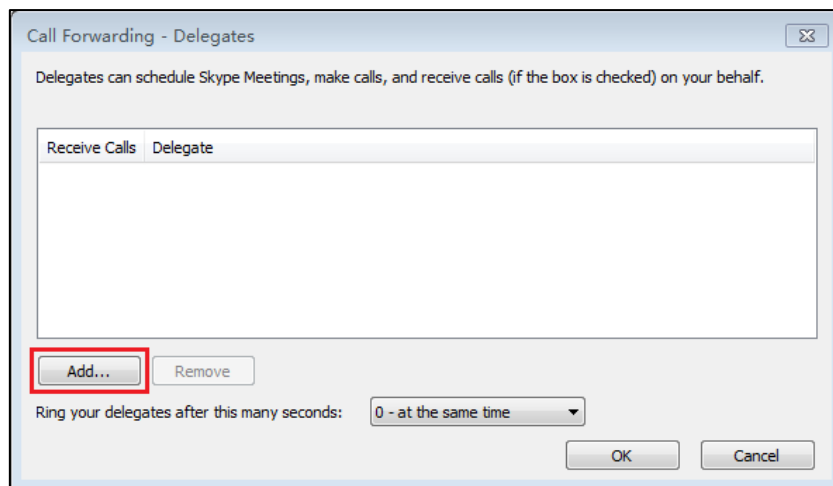

7. Select the desired delegates from the **Choose a Delegate** dialog box.

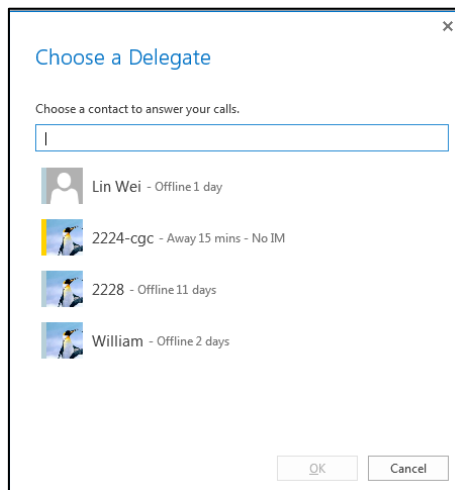

8. Click **OK**.
9. Click **OK** in the **Delegates** dialog box.
10. Click **OK** in the **Options** dialog box.

**To remove a delegate from Skype for Business client:**

1. Open Skype for Business client.
2. Sign into Skype for Business client as the person who wants to remove a delegate. Make sure **My Delegates** option is not selected in either the **Simultaneously ring** or **Forward my calls to** list.

3. Click Edit my delegate members.

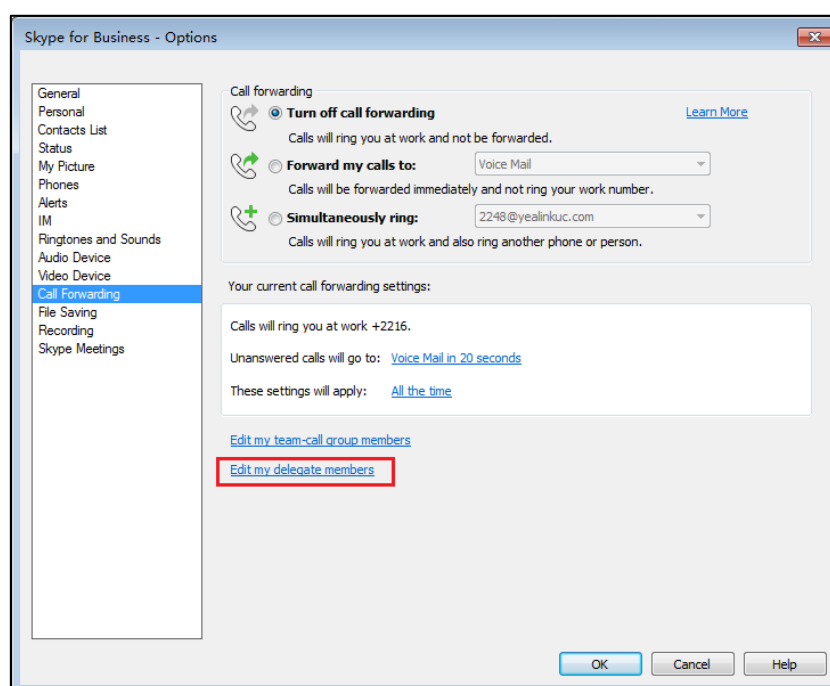

4. Check the checkbox of the delegate you want to remove.

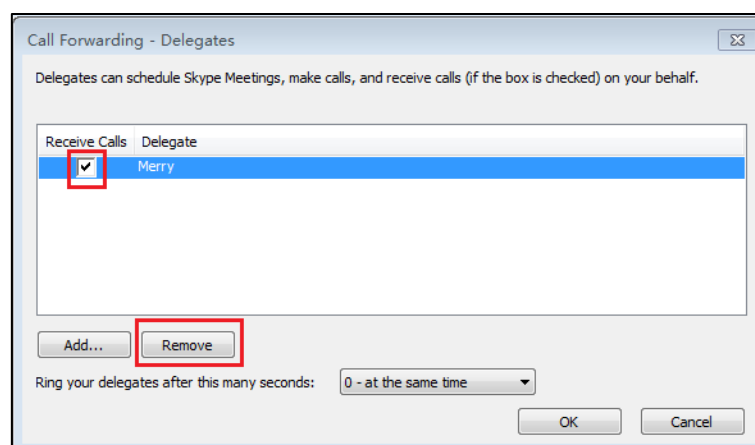

5. Click **Remove**.
6. Click **OK** in the **Delegates** dialog box.
7. Click **OK** in the **Options** dialog box.

## Viewing the Bosses/Delegates

### Viewing the Bosses

Once a user is assigned to be a delegate of the boss on the Skype for Business client, a **Bosses** group will appear on the delegate's phone automatically.

**To view your bosses:**

1. Press  -> **Bosses**.  
Your boss(es) will be displayed.

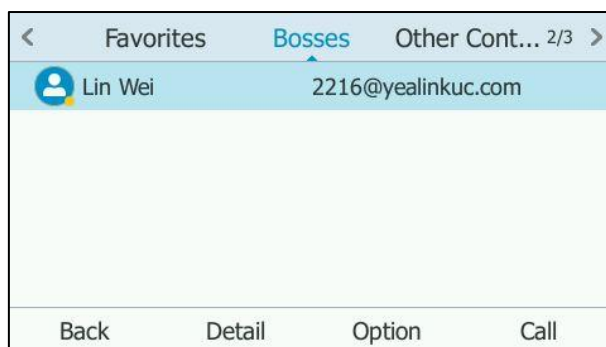

## Viewing the Delegates

Once a boss is assigned delegates on the Skype for Business client, a **Delegates** group will appear on the boss's phone automatically.

**To view your delegates:**

1. Press  -> **Delegates**.  
Your delegate(s) will be displayed.

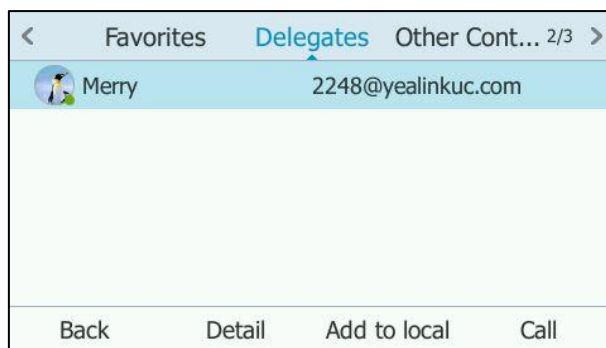

## Using the Boss-Admin Feature

### Answering Incoming Calls

When a user calls the boss, both boss's and delegate's phone will ring simultaneously.

**To answer an incoming call on a boss's phone:**

1. Press the **Answer** soft key or  .

The delegate's phone stops ringing and the LCD screen of the delegate's phone is shown below:

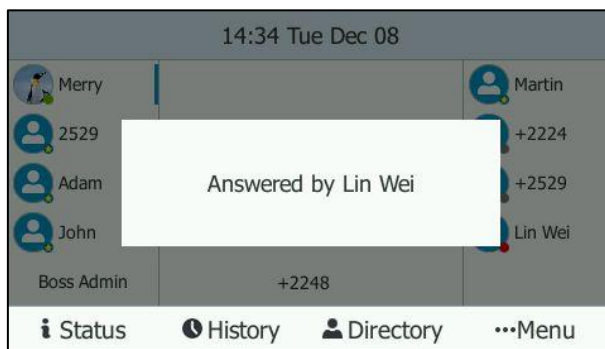

**To answer an incoming call on a delegate's phone:**

1. Press the **Answer** soft key or  .

The boss's phone stops ringing and the LCD screen of the boss's phone is shown below:

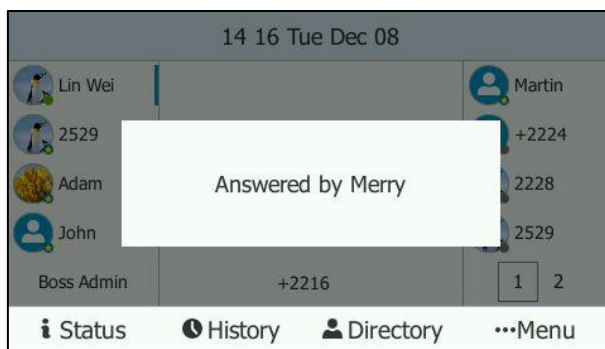

## Placing the Calls on Hold

**To place a call on hold on a boss's phone:**

1. Press the **Hold** soft key or  to place the call on hold.

The **Boss Admin** line key LED of the delegate's phone flashes green. The Boss/Admin screen appears on the delegate's phone.



(A call from 2224-cgc to Lin Wei)



**To place a call on hold on a delegate's phone:**

1. Press the **Hold** soft key or  to place the call on hold.

The **Boss Admin** line key LED of the boss's phone flashes green. The Boss/Admin screen appears on the boss's phone.



(A call from 2224-cgc to Lin Wei)

## Resuming the Held Calls

Either boss or delegate can resume the held call. Once one party resumes the call, the other party will drop the call automatically.

**To resume a call held on a boss's phone:**

Do one of the following:

- The boss presses the **Resume** soft key or  to resume the held call.

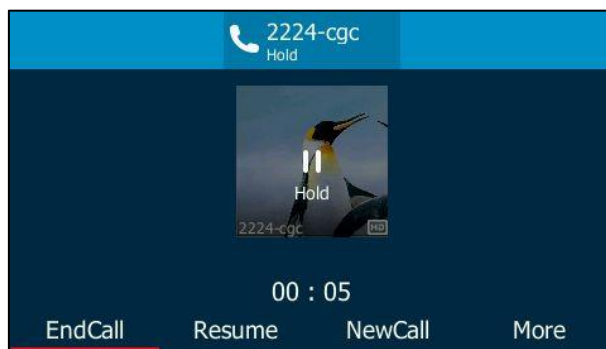

- The delegate presses the **Boss Admin** line key to view the calls that are held by boss.



(A call from 2224-cgc to Lin Wei)

Press the **Resume** soft key. The call will be resumed by delegate, and the boss will drop the call automatically.

**To resume a call held on a delegate's phone:**

Do one of the following:

- The delegate presses the **Resume** soft key or  to resume the held call.

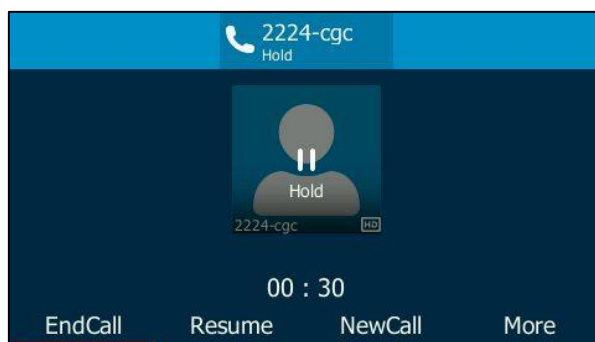

- The boss presses the **Boss Admin** line key to view the calls that are held by delegate.

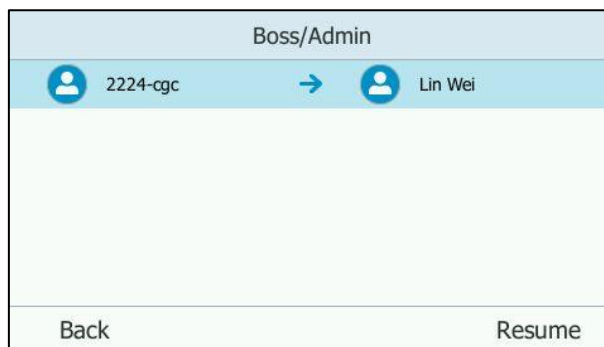

(A call from 2224-cgc to Lin Wei)

Press the **Resume** soft key. The call will be resumed by the boss, and the delegate

will drop the call automatically.

## Transferring Calls to Boss Voicemails

If a boss is unavailable to answer calls, delegates can transfer the calls directly to a boss's voicemail. The caller can follow the voice prompt to leave the voice mail.

### To transfer a delegation call to the boss's voicemail:

Do one of the following:

- Before the delegate answers the incoming call:  
Press the **BossVM** soft key to forward the incoming call to boss's voice mail directly.  
The LCD screen of the delegate's phone is shown below:

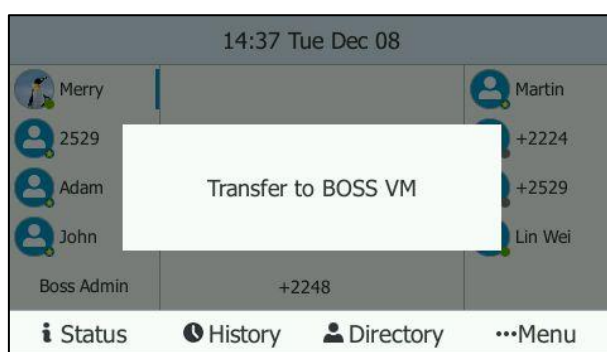

- After the delegate answers the call:  
Press **More->BossVM** to transfer the call to boss's voice mail directly.  
The LCD screen of the delegate's phone is shown below:

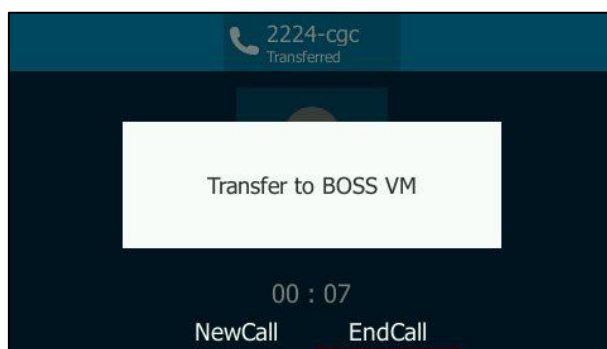

## Making a Safe Transfer to Boss

After a delegate answers a delegation call, the delegate can transfer the call to the boss's phone using Safe Transfer, which enables the delegate to transfer the call to the boss's phone and prevent the call from going to the voice mail if the boss does not answer the call.

**To make a safe transfer to a boss’s phone:**

1. Press **More->Safe Tran** during a call. The call is placed on hold.

When the boss answers the call, the call will be transferred to the boss successfully.

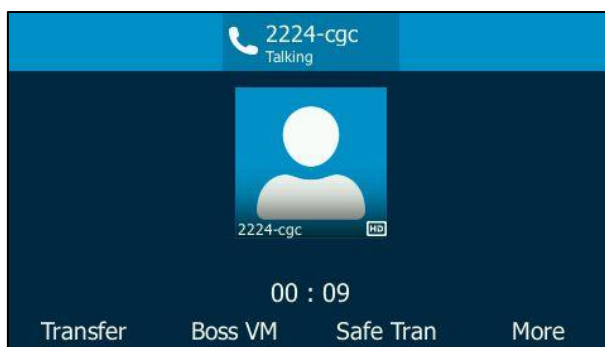

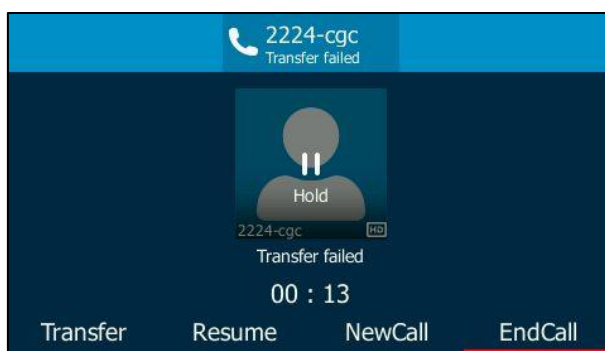

When the boss is not available to answer the transferred call or rejects the transferred call, the delegate’s phone displays as “Transfer failed”. The delegate can resume the call.







## Calling on Behalf of a Boss

The delegate can make calls on behalf of his assigned boss’s lines.

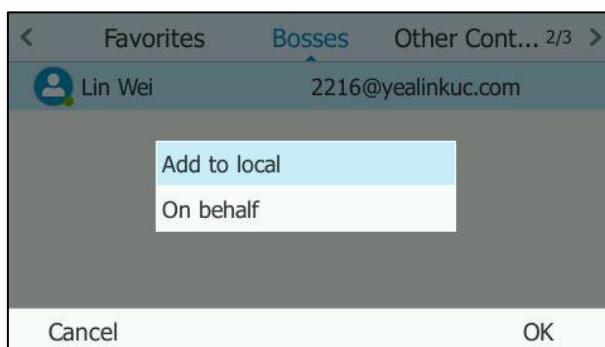
**To place a call on behalf of a boss’s line:**

1. Press  -> **Bosses**.
2. Press  or  to select the desired boss.
3. Press the **Option** soft key.



4. Press  or  to select **On behalf** from the prompt list.
5. Enter the number or press the **Directory** soft key to select the desired contact, and then press , , or the **Send** soft key.

The call displays “Calling On behalf of XXX” on the delegate’s phone.

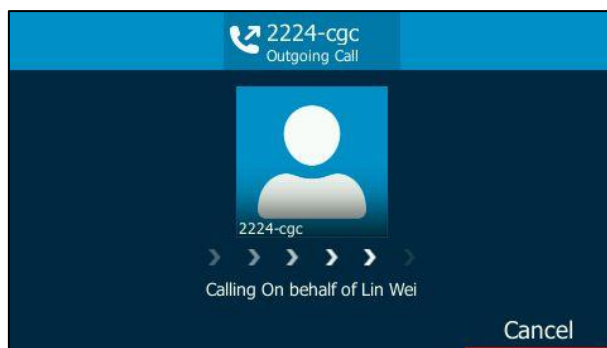

The delegate displays a notification after the third-party answers the phone. As shown below:

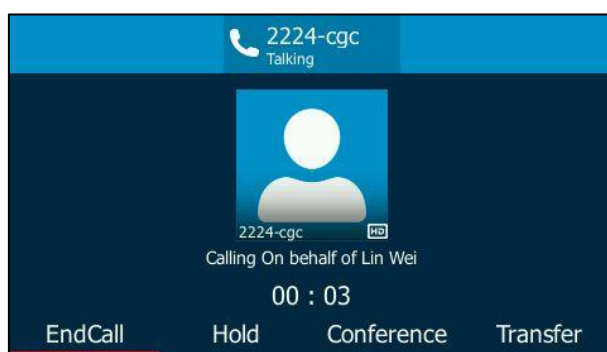

## Joining Conference Calls

The delegate can join an incoming conference call on behalf of a boss’s line and add the boss to the conference call.

**To add a boss’s line to a conference call:**

1. Press the **Answer** soft key to join an incoming conference call.

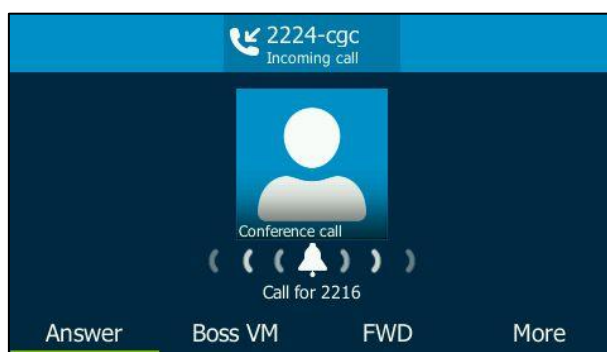

2. If the conference needs the boss to be present, press the **More->Invite** soft key to

add the boss's line to the conference.

The LCD screen of the delegate's phone is shown below:

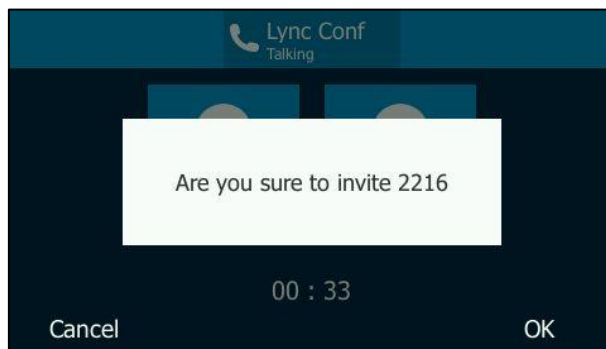

3. Press the **OK** soft key.

The LCD screen of the delegate's phone is shown below:

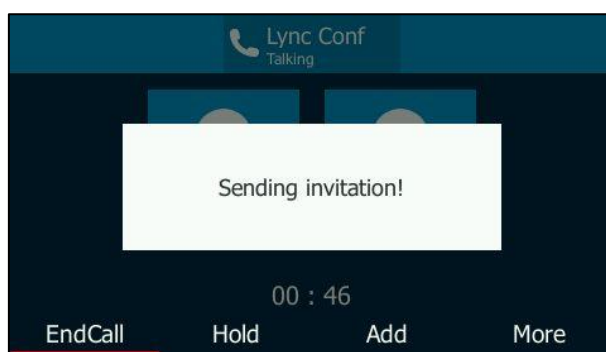

When the boss joins the conference call, the delegate can choose to continue or leave the conference.

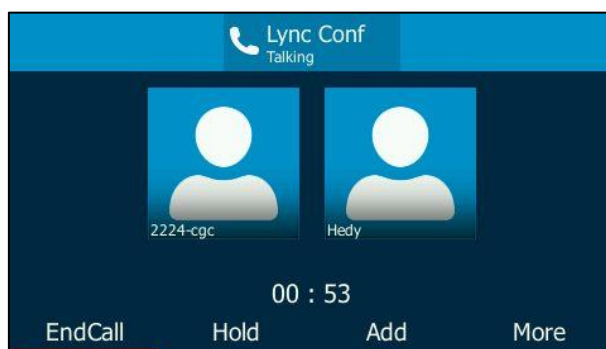

## Inbound Private Line

The Skype for Business Server enables the system administrator to give users a second, private telephone line in addition to their primary telephone line. Private telephone lines are often assigned to bosses who want an unlisted telephone number at which they can be reached directly.

When the boss receives a private call, the private line will bypass call delegation and

only his/her phone rings even though a secretary has been designated as his/her delegate for ring simultaneously feature.

The system administrator can assign a private line to boss in one of the following situations occurs:

- The boss doesn't want to miss important calls denied by his DND status.
- The boss doesn't want the delegate to answer some important or confidential calls for him.
- The boss wishes his friends and families to reach him directly or bypass his delegate.

In many organizations, bosses have administrative secretaries who answer their office phones for them. This is easily accomplished on the Skype for Business Server by using call delegation. As a result, if one people dial the primary line of the boss, the phones of the delegate will ring simultaneously. If the people dial the private line of the boss, only boss's phone rings.

#### Characteristics of Private Lines:

- A user can have only one private line.
- A user with a private line has only one voice mailbox.
- Calls to the private telephone line ring through. They do not follow "Do Not Disturb" rules.
- Private lines are inbound only and cannot be used to make outgoing calls.
- None of the following features are available with a private telephone line: delegation, and Response Group application.

For more information on planning for private telephone lines, refer to [Plan for private telephone lines](#).

When receiving a private call, the LCD screen of the phone will prompt "Call for private line":

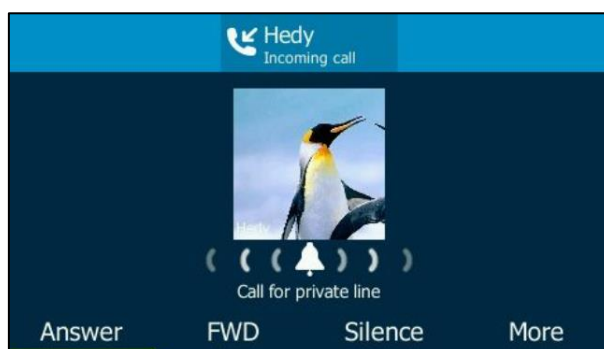

#### Note

Private lines can only be configured on the Skype for Business client only. Contact your administrator for more information.

## Call Transfer

You can transfer a call to another party in one of the two ways:

- **Blind Transfer:** Connect a second party to a third party before the third party answers.
- **Attended Transfer:** Connect a second party to a third party after the third party answers and agrees to take the call from the second party.



### Blind Transfer

To perform a blind transfer during a call:

1. Press  or the **Transfer** soft key during a call.



2. Enter the number press the **Directory** soft key to select the desired contact from the contact list you want to transfer the call to.

You can also enter the first few continuous characters of the contact name, phone number or the contact address, and then press  or  to scroll through the result list and select the desired contact.

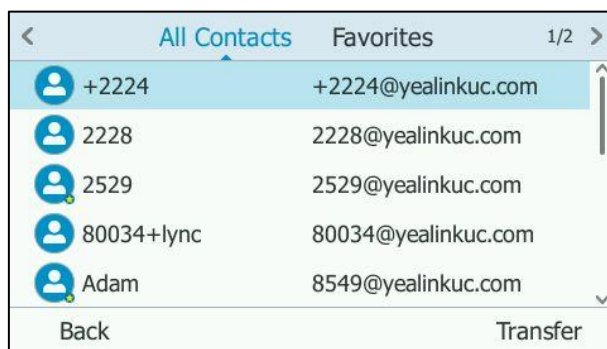

3. Press  or the **Transfer** soft key to complete the transfer.  
Then the call is connected to the number to which you are transferring.





## Attended Transfer

To perform an attended transfer:

1. Press  or the **Transfer** soft key during a call.



2. Enter the number or press the **Directory** soft key to select the desired contact from the contact list you want to transfer the call to.  
You can also enter the first few continuous characters of the contact name, phone number or the contact address, and then press the navigation keys to scroll through the result list and highlight the desired contact.
3. Press  or  to dial out.
4. After the party answers the call, press  or **Transfer** soft key to complete the transfer.

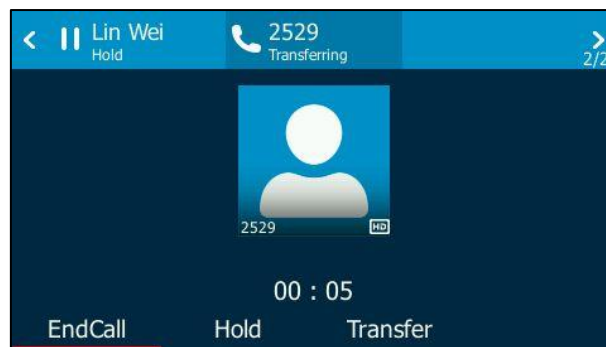

If you are using a handset, the transfer can be completed by hanging up the handset. You can cancel the transfer by pressing the **Cancel** soft key before the call is answered.

## Group Call Pickup

Group call pickup is used for picking up incoming calls within a pre-defined group. If the group receives many incoming calls at once, the user will pick up the first incoming call, by dialing the group pickup code. This feature depends on support from a Skype for Business Server.

### Note

Group and group pickup code are configurable on the Skype for Business Server only. Contact your system administrator for more information.

### To use group pickup via phone user interface:

1. Enter the group pickup code (e.g., #505) on your phone when a phone number in your group receives an incoming call.



2. Press the **Send** soft key.  
The call is answered on your phone.

## Skype for Business Conference

This chapter provides basic operating instructions for managing Skype for Business conference. You can initiate a Skype for Business conference call on your phone or on the Skype for Business client. You can view the conference participants. And you can also manage the conference participants (e.g., promote or demote conference participants, enable or disable announcements).

### Initiating a Skype Conference Call

You can initiate a Skype for Business conference call on your phone or on the Skype for Business client.

### Note



You can join a Skype conference from the calendar. For more information, refer to [Joining Skype Conferences from the Calendar](#) on page 109.

## Initiating a Skype Conference Call during a Call

### Initiating a Skype Conference Call from the Phone

You can initiate a Skype for Business conference call, add and invite contacts to a conference call from phone.

**To initiate a Skype for Business conference call via phone user interface:**

1. Place a call to the first party.
2. When the first party answers the call, press the **Conference** soft key to invite a new call to the Skype for Business conference.
3. Enter the number of the third party, and then press , , or the **Send** soft key.

You can also enter the first few continuous characters of the contact name, phone number or the contact address, and then press the navigation keys to scroll through the result list and select the desired contact.

4. When the third party answers, three parties are now joined in the Skype conference.



5. Press the **Add** soft key to invite a new party.
6. Repeat the steps 3-4 to add more parties to the conference.

## Initiating a Skype Conference Call from the Skype for Business Client

You can initiate a Skype conference call on the Skype for Business client.

**To initiate a Skype for Business conference call from the Skype for Business Client:**

1. Place a call to the first party.



2. Click  to enter the number or name of the third party, and then click **OK** to invite a new call to the Skype for Business conference.

You can also enter the first few characters of the contact name or the contact number. Then select the desired contact from the result list, the call will be placed directly.

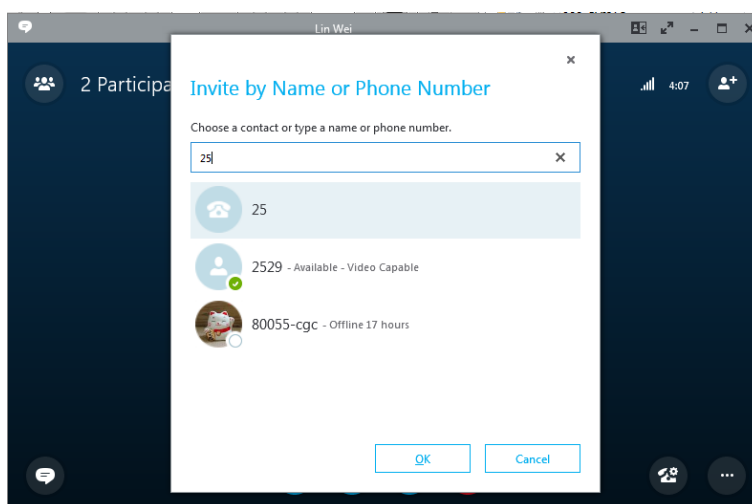

3. When the third party answers, three parties are now joined in the conference.
4. Click  to invite a new party.

- Repeat the steps 2-3 to add more parties to the conference.



## Initiating a Skype Conference Call by Meet Now

### Initiating a Skype Conference Call from the Phone

To initiate a Skype for Business conference call by meet now via phone user interface:

- Press **Menu**->**Meet Now**.

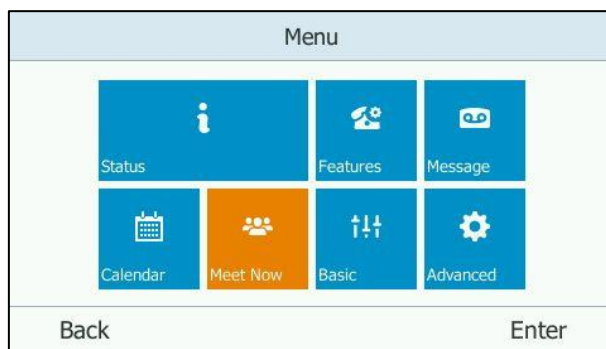

You will initiate a Skype for Business conference call directly.

- Press the **Add** soft key.
- Enter the desired number, and then press the **Send** soft key.  
You can also press the **Directory** soft key or line key to select the desired contact.
- Repeat steps 2-3 to add more parties to the conference.

## Initiating a Skype Conference Call from the Skype for Business Client

To initiate a Skype for Business conference call by meet now from the Skype for Business client:

1. Click  on the Skype for Business client, and then select **Meet Now**.

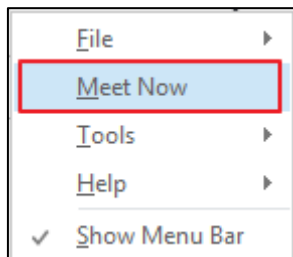

You will initiate a Skype for Business conference call directly.

2. Click  to enter the number or name of the third party, and then click **OK** to invite a new call to the Skype for Business conference.

You can also enter the first few characters of the contact name or the contact number. Then select the desired contact from the result list, the call will be placed directly.

3. Repeat step 2 to add more parties to the conference.

## Viewing the Dial-in Number and Conference ID

You can view the dial-in number and conference ID when you initiate or join a Skype for Business conference.

To view the dial-in number and conference ID via phone user interface:

1. During a Skype for Business conference, press **More->Conf Info** to view the dial-in number and conference ID.





2. Notify other parties of the dial-in number and conference ID, other parties can use the dial-in number and conference ID to join this Skype for Business conference. If this conference is locked, anyone that tries to join the call will enter the lobby until

the organizer or presenters accept(s) the call. For more information, refer to [Locking or Unlocking the Conference](#) on page 148.

## Viewing the Conference Participants

When you initiate or join a conference call, you can view the conference participants.



Conference participants consist of the following three roles:

- **Organizer** (  ): A user who creates a conference. Organizer can manage the presenters and attendees.
- **Presenter** (  ): The participant who is invited to the conference will be a presenter by default. The presenter can only manage other presenters and attendees.
- **Attendee** (  ): A user who is invited to a conference but who is not authorized to act as a presenter. The attendee can hold or resume the conference, mute or unmute himself and leave the conference only.



**To view the conference participants via phone user interface:**

1. Press **More->Members** to view the conference participants' information during a conference.



2. Press  or  to view the conference participants information.
3. Press the **Back** soft key to return to the previous screen.

## Managing the Conference Participants

When you initiate a Skype for Business conference call, you will be an organizer (displays  icon) and other participants are listed as presenters (display  icon) by default.

## Holding or Resuming the Conference Call

All participants can place the conference call on hold.

**To place the conference call on hold:**

1. Press the **Hold** soft key during an active conference call.  
Other participants can hear each other.

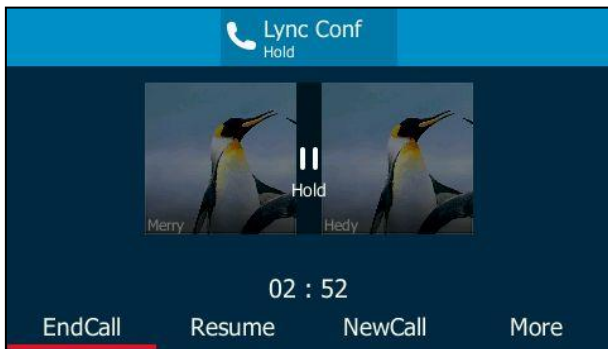

**Note** The phone will beep softly every 30 seconds to remind you that you still have a call on hold.



**To resume the held conference call:**

1. Press the **Resume** soft key.

## Muting or Unmuting Conference Participants

All participants can mute or unmute themselves. But only the organizer and presenters can mute or unmute other conference participants.

**To mute the conference participants by organizer or presenters:**

1. Press **More->Members**.
2. Press  or  to select the desired participant.



3. Press the **Far Mute** soft key.  
The muted participant can hear other participants, but other participants cannot



hear the muted participant.

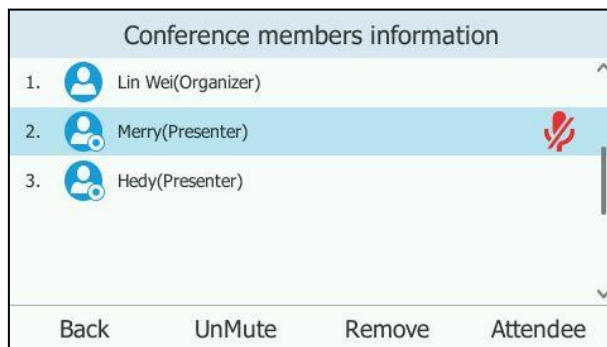

The mute icon  is displayed at the right of the participant who is muted.

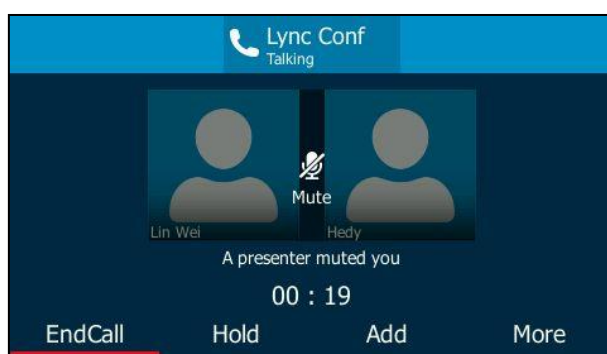

The mute key LED of the muted participant's phone illuminates solid red. The LCD screen of the muted participant's phone is shown below:



**To unmute the conference participants by organizer or presenters:**

1. Press **More->Members**.
2. Press  or  to select the desired muted participant.



3. Press the **UnMute** soft key.

The LCD screen of the muted participant's phone is shown below:

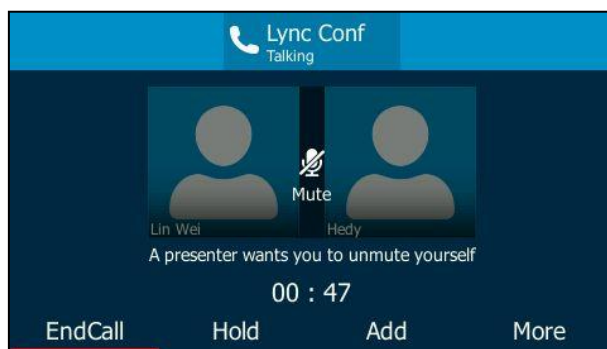



The muted participants can also press  to unmute themselves.

## Promoting or Demoting Conference Participants

The organizer and presenters can promote other conference participants from attendees to presenters, or demote conference participants from presenters to attendees. But they cannot demote or promote themselves. The presenters cannot demote or promote the organizer. The attendees cannot promote or demote every participant.

**To demote conference participant:**

1. Press **More->Members**.
2. Press  or  to select the desired presenter.



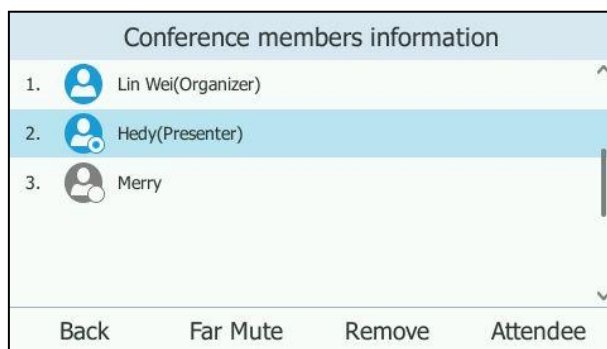

3. Press the **Attendee** soft key to demote a presenter to attendee.

The LCD screen of all participants' phone is shown below:



**To promote conference participant:**

1. Press **More->Members**.
2. Press  or  to select the desired attendee.



3. Press the **Presenter** soft key to promote an attendee to presenter.

The participant is now a presenter who can manage conference attendees. And the LCD screen of all participants' phone is shown below:



## Enabling or Disabling the Announcement

Only the organizer and presenters can enable or disable the announcement.

When the announcement feature is enabled, the phone will play a warning tone when an organizer or presenter removes a conference participant, or when a person joins or leaves the conference.

**To enable conference announcements:**

1. During a conference call, press **More->E.Anc** to enable announcement.



**To disable conference announcements:**

1. During a conference call, press **More->U.Anc** to disable announcement.



## Locking or Unlocking the Conference

Only the organizer and presenters can lock or unlock the conference.

The organizer and presenters can lock a conference call to prevent other people from joining the conference call without an organizer's or presenter's approval.

**To lock a conference:**

1. During an active conference, press **More->ConfLock**.



The icon  appears on the LCD screen.



The conference is locked, and anyone that tries to join the call will enter the lobby and hear music until the organizer or presenters accept the call.

**To unlock a conference:**

1. During an active conference, press **More->ConfUnLock**.

The icon  disappears on the LCD screen.



## Joining the Locked Conference Call

The participant invites a new call to a locked conference:

1. Press the **Add** soft key to invite a new call.



The invitee will enter the lobby until the organizer or presenters accept the call. The LCD screen of the organizer's or presenters' phones is shown below:



**The organizer or presenters admit a new call to join a locked conference:**

When the locked conference receives a call, a number icon (indicating the number of calls waiting in the lobby) will appear on . When the organizer admits or rejects the caller to join the locked conference, the number icon (indicating a call waiting in the lobby) will disappear.

1. Press **More->Lobby** to view the caller waiting in the lobby.



2. Do one of the following:

- Press the **Admit** soft key.

The caller joins the locked conference as a presenter successfully.



- Press the **Reject** soft key.



The caller fails to join the locked conference, and the caller drops the call automatically.



## Removing Conference Participants

All conference participants cannot remove themselves. An organizer can remove presenters and attendees. A presenter can remove other presenters and attendees.

**To remove a conference participant:**

1. Press **More->Members**.
2. Press  or  to select the desired participant, and then press the **Remove** soft key to remove the participant from the conference.

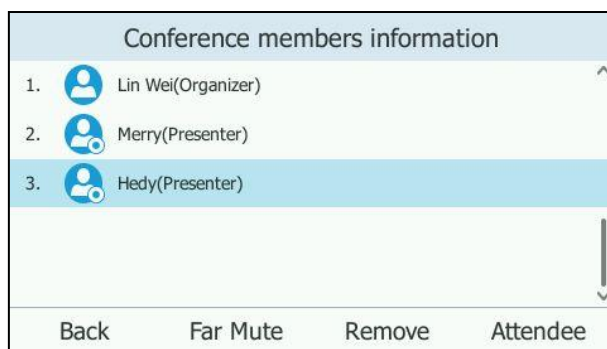

A notification is displayed on the phone informing that the participant removes them from the conference.

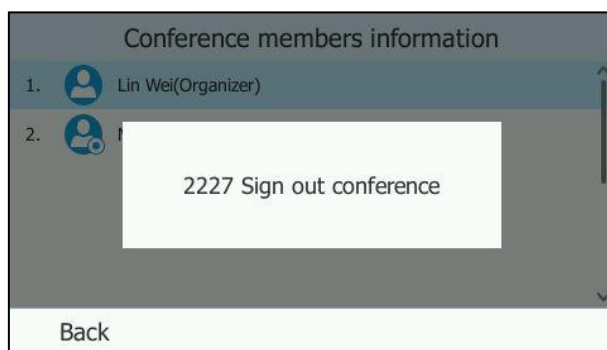

## Leaving the Conference

All participants can leave the conference at any moment.

### To leave the conference:

1. Press the **EndCall** soft key.  
Other participants remain connected.



A notification is displayed on other participants' phone informing that the participant removes from the conference.

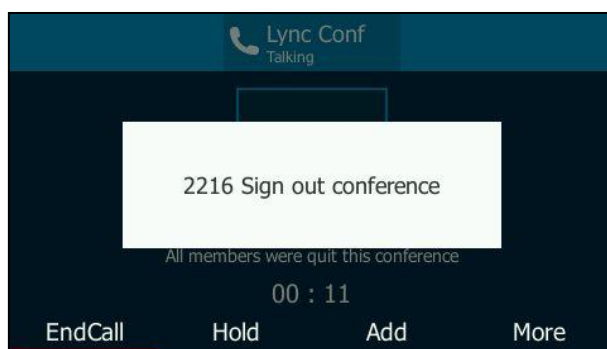

## Call Park

You can use call park feature to place a call on hold, and then retrieve the call later or from another phone in the system (for example, a phone in another office or conference room). You can park an active call by pressing the **Park** soft key on the phone. If the call is parked successfully, a visible prompt will be displayed on the touch screen of each party confirming that the call was parked.

Call park is different from call hold. Call hold keeps the held call on the same line, while call park places the call in a call orbit on the Skype for Business Server. Calls placed in the call orbit are given an orbit number and can be retrieved by any Skype for Business-compatible phone with access to the orbit.

### To use call park:

1. User on phone A is during a call with user on phone B.



- User on phone A wants to deal with some things or take the call in a conference room for privacy, then press **Park** soft key on phone A.

The LCD screen of phone A displays the call park orbit number.



**To retrieve the parked call on phone A:**

After things are processed, user on phone A presses **Retrieve** soft key to retrieve the parked call.

**To retrieve the parked call on phone C:**

User walks to an available conference room where the phone is designated as phone C. The user uses phone C to dial the call park orbit number (appearing on phone A) to retrieve the parked call.

The LCD screen of phone A will prompt that the parked call is retrieved by phone C.



Two-way voice path is established between phone C and B.

**Note**

If the call is hung up by the other party before parker retrieves the parked call, the prompting message "Parked user ended call before being retrieved" will be displayed on the LCD screen of parker.

The parker will receive a ring back if the parked call is not retrieved by anyone after timeout expires. If the parker does not answer or reject the ring back, the call will be terminated and will not get redirected to voice mail.

## Voice Mail

You can leave voice mails for someone else using the SIP-T46G IP phone. You can also listen to voice mails that are stored in a voice mailbox. When receiving a new voice mail, the phone will play a warning tone. A number icon (indicating the number of voice mails you haven't retrieved) appears on the top-right of the **Message** menu.

Press **...** to enter the **Menu** screen, and the number icon also appears on the top-right of the **Message** menu.

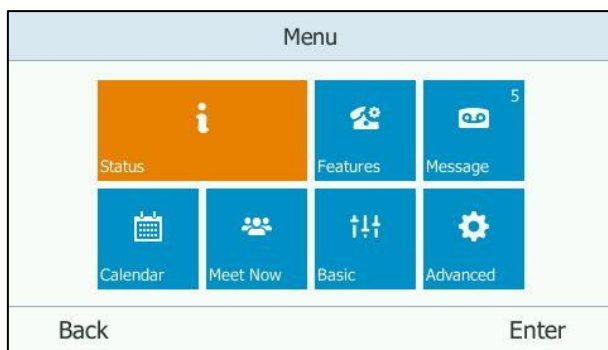

### Note

First time you listen to your voice mails, the message center will ask you to configure a voice mail access PIN.

When all new voice mails are retrieved, the flashing power indicator LED will go out and the number on **Message** menu icon will disappear.

## Leaving the Voice Mail

You can leave a voice mail for someone else when he/she is busy or inconvenient to answer the call. Follow the voice prompt from the system server to leave a voice mail, and then hang up.

## Managing the Voice Mail

### PIN Authentication

When you sign into the phone using [PIN Sign-in](#) method, you can follow the voice prompts to listen to voice mails only.

To listen to the voice mail when sign into the phone using PIN Authentication, do the following:

1. When the LCD screen prompts that the phone receives a new voice mail and the power indicator LED slow flashes red, press  or press **...** ->**Message**.

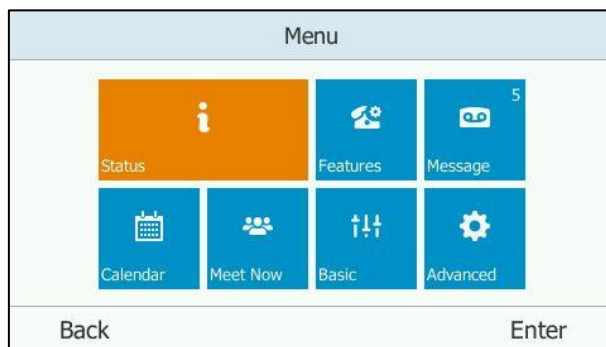

2. Follow the voice prompt to listen to your voice mails.

## User Sign-in/Device Pairing for Online/BToE Sign-in

When you sign into the phone using User Sign-in, Device Pairing for Online or [BToE Sign-in](#) method, you can manage the voice mail, includes viewing a list of voice mails, call back to those who left the voice mails list, mark voice mails as read, delete voice mails and follow the voice prompts to listen to voice mails, etc.

## Accessing the Message Center

To access the message center:

1. When the LCD screen prompts that the phone receives a new voice mail and the power indicator LED slow flashes red, do one of the following to access the message center:
  - press .
  - Press **...** ->**Message**, and then press the **Message** soft key.



2. Follow the voice prompt to listen to your voice mails.

## Listening to the Voice Mail

To listen to the voice mail:

1. Press **...** -> **Message**.

You can view the contacts that left the voice mails, the received date, the contact's presence status and the status of the visual voice mails.

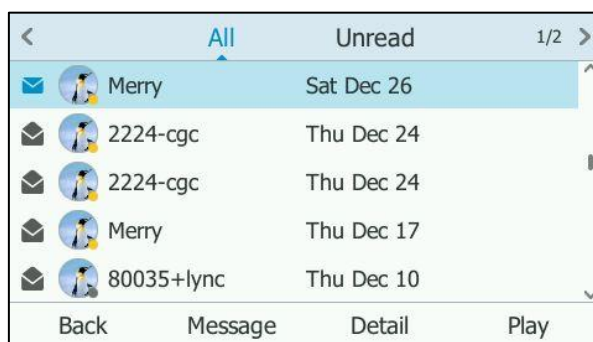

2. Press **◀** or **▶** to switch between unread voice mails and all voice mails.



3. Press **▲** or **▼** to select the desired voice mail.
4. Press the **Play** soft key, the phone will connect to the Exchange server to play the selected voice mail.

### Note

The phone can accept an incoming call while it is connected to Exchange to play a single or all voice mails. The call with the exchange becomes hold when the phone accepts the incoming call.

## Calling a Contact

To call a contact:

1. Press **...** ->Message.

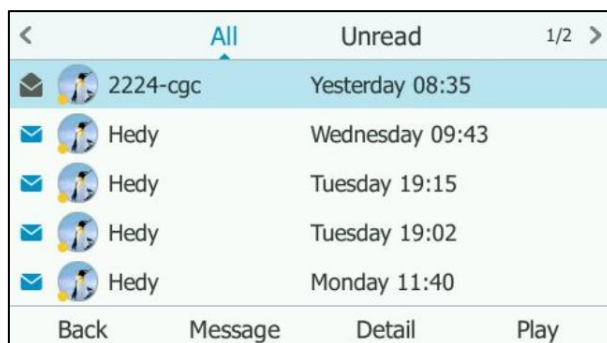

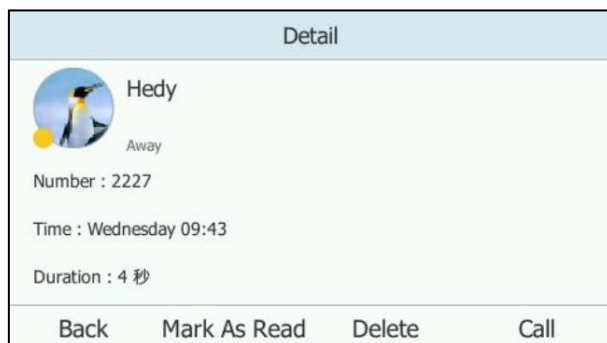

2. Press **▲** or **▼** to select the desired voice mail.
3. Press the **Detail** soft key to view the detail, and then press the **Call** soft key to call the contact.





## Marking the Voice Mail as Read

The following icons indicate the status of the voice mail:

-  Unread voice mail
-  Read voice mail

To mark the voice mail as read:

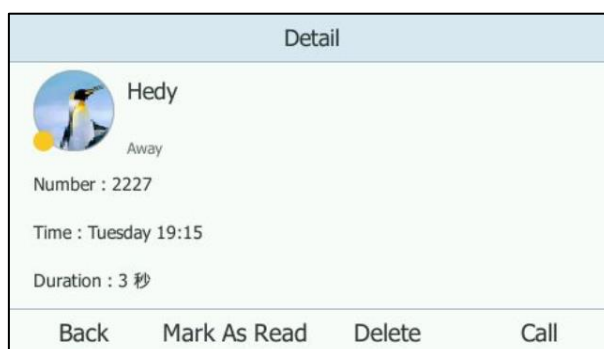

1. Press **...** ->Message.
2. Press **▲** or **▼** to select the unread voice mails.
3. Press the **Detail** soft key to view the detail.
4. Press the **Mark As Read** soft key.

The voice mail icon will change from  to .



## Deleting the Voice Mail

**To delete the voice mail:**

1. Press **...** -> Message.
2. Press  or  to select the desired voice mail.
3. Press the **Detail** soft key to view the detail, and then press the **Delete** soft key.

The voice mail you selected will be deleted directly.

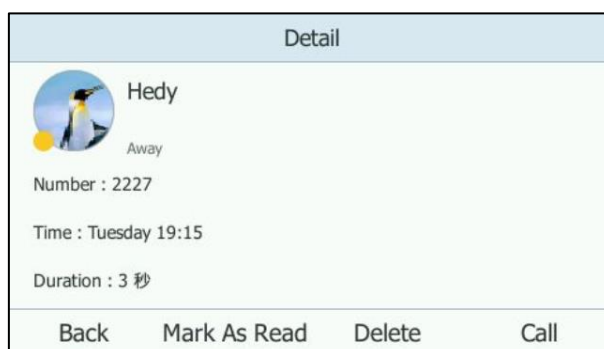



## Multicast Paging

You can use multicast paging to quickly and easily broadcast time sensitive announcements to users who are listening to a specific multicast group. You can configure the paging list on the phone, which allows you to send a Real Time Transport Protocol (RTP) stream to the pre-configured multicast address(es) without involving SIP signaling. You can configure the phone to receive an RTP stream from pre-configured multicast listening address(es) without involving SIP signaling. You can specify up to 10 multicast listening addresses.

## Sending RTP Stream

To configure paging list via phone user interface:

1. Press **Menu->Features->Paging List**.
2. Press  or  to select a desired paging group.  
The default tag is Empty if it is not configured before.

Paging List		
1. (Empty)		↑
2. (Empty)		
3. (Empty)		
4. (Empty)		
5. (Empty)		
Back	Option	Paging

3. Press the **Option** soft key, and then press the **Edit** soft key.
4. Enter the multicast IP address and port number (e.g., 224.5.6.20:10008) in the **Address** field.

The valid multicast IP addresses range from 224.0.0.0 to 239.255.255.255.

Edit Paging Address	
1. Number:	1
2. Address:	<input type="text" value="224.5.6.20:10008"/>
3. Label:	<input type="text"/>
Back	123 Delete Save

5. Enter the group name in the **Label** field.
6. Press the **Save** soft key to accept the change.

If the paging group is configured successfully, the second line key is assigned as the paging key automatically. You can press it to enter the paging list.



7. Repeat steps 2 to 6, you can add more paging groups.

**To delete a paging group via phone user interface:**

1. Press the second line key (indicating the paging key) or press **Menu->Features->Paging List** when the phone is idle.
2. Press or to select a desired group.
3. Press the **Option** soft key, and then select **Delete** soft key.

The LCD screen prompts “Delete selected paging group?”.

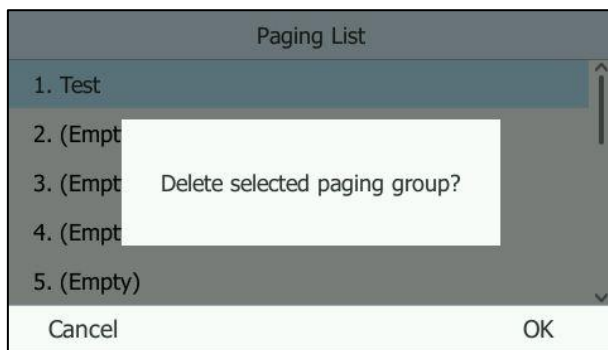

4. Press the **OK** soft key to accept the change or the **Cancel** soft key to cancel.

If you want to delete all paging groups, you can press the **Delete All** soft key.

Paging list is configurable via web user interface at the path **Directory->Multicast IP**.

You can also configure the phone to use a codec for sending multicast RTP stream via web user interface.

**To configure a default codec for multicast paging via web user interface:**

1. Click on **Features->General Information**.
2. Select the desired codec from the pull-down list of **Multicast Codec**.



The default codec is G722.

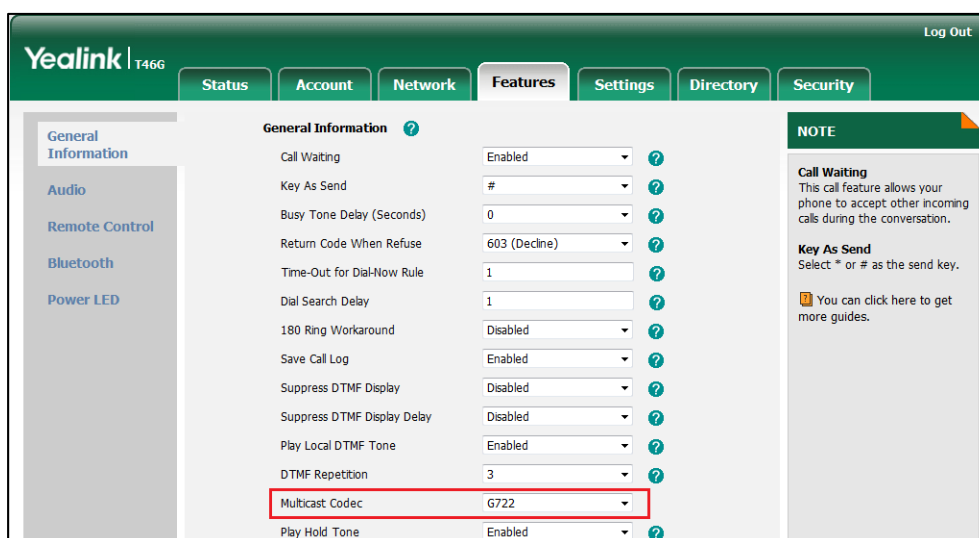

3. Click **Confirm** to accept the change.

**Note** If G722 codec is used for multicast paging, the LCD screen will display the **HD** icon to indicate that it is providing high definition voice.

Default codec for multicast paging is configurable via web user interface only.

## Receiving RTP Stream

You can configure the phone to receive a Real Time Transport Protocol (RTP) stream from the pre-configured multicast address(es) without involving SIP signaling. You can specify up to 10 multicast addresses that the phone listens to on the network.

How the phone handles incoming multicast paging calls depends on Paging Barge and Paging Priority Active parameters configured via web user interface.

### Paging Barge

The Paging Barge parameter defines the priority of the voice call in progress. If the priority of an incoming multicast paging call is lower than that of the active call, it will be ignored automatically. If Disabled is selected from the pull-down list of Paging Barge, the voice call in progress will take precedence over all incoming multicast paging calls. Valid values in the Paging Barge field:

- **1 to 10:** Define the priority of the active call, 1 with the highest priority, 10 with the lowest.
- **Disabled:** The voice call in progress will take precedence over all incoming paging calls.

## Paging Priority Active

The Paging Priority Active parameter decides how the phone handles incoming multicast paging calls when there is already a multicast paging call on the phone. If enabled, the phone will ignore incoming multicast paging calls with lower priorities, otherwise, the phone will answer incoming multicast paging calls automatically and place the previous multicast paging call on hold. If disabled, the phone will automatically ignore all incoming multicast paging calls.

### To configure multicast listening addresses via web user interface:

1. Click on **Directory->Multicast IP**.
2. Select the desired value from the pull-down list of **Paging Barge**.
3. Select the desired value from the pull-down list of **Paging Priority Active**.
4. Enter the multicast IP address(es) and port number (e.g., 224.5.6.20:10008) which the phone listens to for incoming RTP multicast in the **Listening Address** field.
5. Enter the label in the **Label** field.

Label will appear on the LCD screen when receiving the multicast RTP stream.

IP Address	Listening Address	Label	priority
1 IP Address	224.5.6.20:10008	Test	1
2 IP Address			2
3 IP Address			3
4 IP Address			4
5 IP Address			5
6 IP Address			6
7 IP Address			7
8 IP Address			8
9 IP Address			9
10 IP Address			10

6. Click **Confirm** to accept the change.

### Note

The priorities of listening addresses are predefined: 1 with the highest priority, 10 with the lowest.

Multicast listening addresses are configurable via web user interface only.

## Using Multicast Paging

### To send RTP stream via the paging list:

1. Do one of the following to enter the paging list.
  - When the phone is idle, press the second line key (indicating the paging key)

or press **Menu->Features->Paging List**.

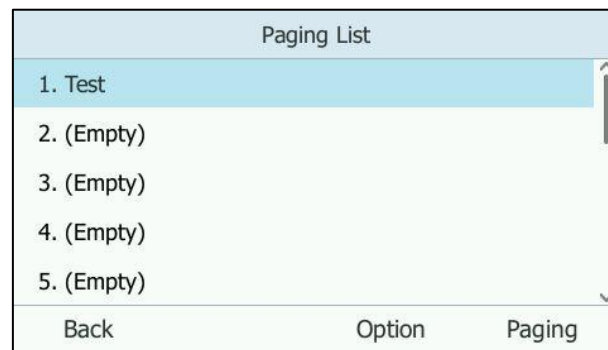

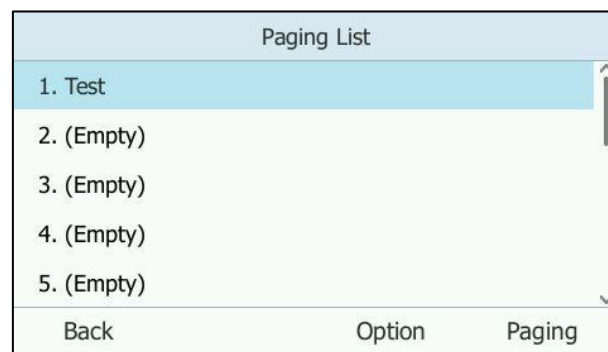

- During a call, press the second line key (indicating the paging key).

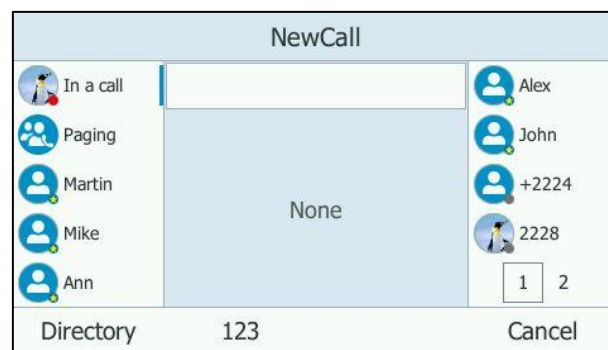

- During a call, press **Hold** soft key, and then press **More->NewCall**, and then press the second line key (indicating the paging key).



2. Press  or  to select the desired group.

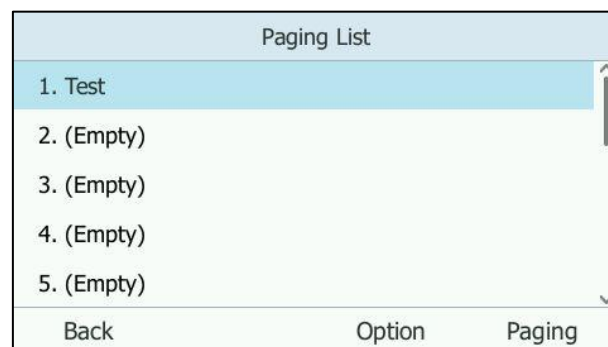

3. Press  or the **Paging** soft key to send RTP.

Both the sender's and receiver's phones play a warning tone and the receiver automatically answers the multicast RTP session in the speakerphone mode.

The following figure shows a multicast RTP session on the phone:

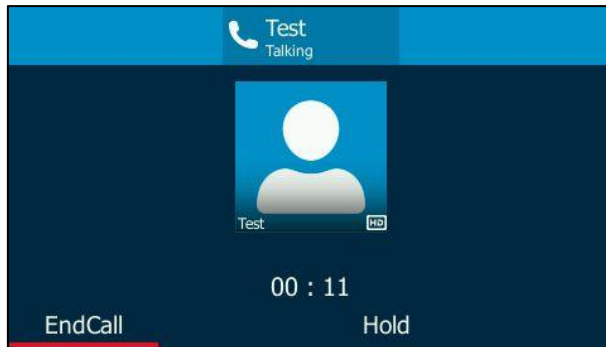

4. To place the current multicast RTP session on hold, press the **Hold** soft key.  
The sender's phone places the multicast RTP session on hold and receiver's phone releases the session.
5. To resume the held multicast RTP session, press the **Resume** soft key.  
The multicast RTP session is established again.
6. To end the multicast RTP session, press the **EndCall** soft key.

#### Note

Multicast RTP is one way only from the sender to the multicast address(es) (receiver). For outgoing RTP multicasts, all other existing calls on the phone will be placed on hold.

## Branch Office Resiliency

Branch office resiliency is critical for multi-site deployments of Skype for Business where the control servers are located at a central site or data center. It allows branch site users to continue to have Enterprise Voice service and voice mail (if voice mail rerouting settings are configured) when the branch site loses the connection to the central site.

When the WAN connection between the branch site and central site is unavailable, the phone goes into resiliency mode:

- Branch site user on the phone stays signed in with an indication of "Limited service due to outage".
- Call between branch site users is established successfully with 2-way audio.
- Conference between branch site users can be established successfully.
- The call history cannot get modified. (Already downloaded call log entries will not be deleted).
- Calls can be placed from the call history on the phone.
- Contact list is unavailable but you can search for a contact on the phone.

- Presence icon on the phone touch screen is displayed as ● (Unknown).
- User is not able to change his presence status manually.
- User is not able to use calendar feature.
- User is not able to receive the voice mail as exchange is unreachable.
- Calls between the branch office phones can be transferred to another branch site user.
- Call forward settings cannot be changed.

When the WAN connection between the branch site and central site becomes available, the phone comes out of resiliency mode automatically. Notification of resiliency is automatically dismissed, and you can use phone features as normal.

**Note**

For more information on branch office resiliency, contact your system administrator.



## Common Area Phone

Common area phones are IP phones that are not associated with an individual user. Instead of being located in someone's office, common area phones are typically located in building lobbies, cafeterias, employee lounges, conference rooms, and other locations where a large number of people are likely to gather. Unlike other phones on the Skype for Business Server, which are typically maintained by using voice policies and dial plans that are assigned to individual users, common area phones do not have individual users assigned to them.

This chapter explains how to use the Common Area Phone. Topics include:

- [Signing into a Common Area Phone](#)
- [Using a Common Area Phone](#)
- [Switching to a Skype for Business Account](#)
- [Signing out of a Common Area Phone](#)

## Signing into a Common Area Phone

To use the Common Area Phone, you must sign into the phone using [PIN Sign-in](#) or [Device Pairing for Online](#) method.

You need to configure an unlock PIN at the initial sign-in. And it is used to enter the **Advanced** settings.

If the phone signs into a CAP account, the idle screen will be shown as below:

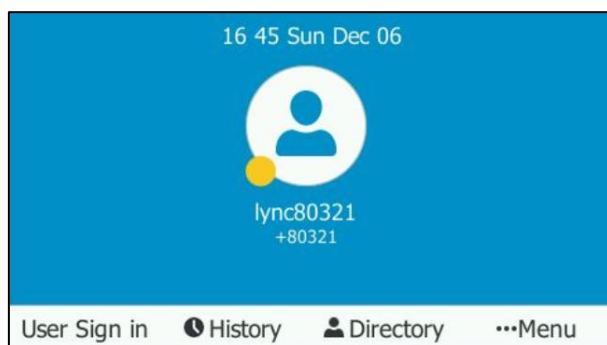

**Note** Your system administrator provides you with login credentials that you can use to sign into a Common Area Phone.

## Using a Common Area Phone

Users should pay attention to the following points when using the Common Area Phone:

- The phone can sign into the last CAP account automatically after the phone recovers from network failure, sever failure or being off line. The phone can sign into the last CAP account automatically after rebooting.
- The phone will not sign into the last CAP account automatically after being reset to factory.

**Available features of the Common Area Phone:**

- The Common Area Phone supports the basic call features, including placing the call, answering the call, placing the call on hold, resuming a held call, muting or unmuting the call and ending the call like a regular phone.
- The Common Area Phone supports switching between a CAP account and a Skype for Business account.
- The Common Area Phone supports the local directory feature.
- The Common Area Phone will switch to away status when screen free time reaches to the set time of the Skype for Business Server.
- If the network administrator enables the advanced feature (e.g., Skype for Business conference, the call park feature, transferring the call) on the Skype for Business Server, you can use these authorized features.

**Unavailable features of the Common Area Phone:**

- The Common Area Phone doesn't have Skype for Business directory.
- The Common Area Phone doesn't have call history feature.
- The Common Area Phone doesn't have phone lock feature, the unlock PIN is used as the administrator password to access the **Advanced** settings.
- The Common Area Phone doesn't have calendar feature.
- The Common Area Phone doesn't have voice mails feature.
- You can't change your presence manually.
- If the network administrator disables the advanced feature (e.g., Skype for Business conference, the call park feature, transferring the call) on the Skype for Business Server, you can't use these unauthorized features.

## Switching to a Skype for Business Account



If the network administrator enables the sign-in configuration on the Skype for Business Server, users can sign into their own Skype for Business account to use Skype for Business features and their own user profile settings.

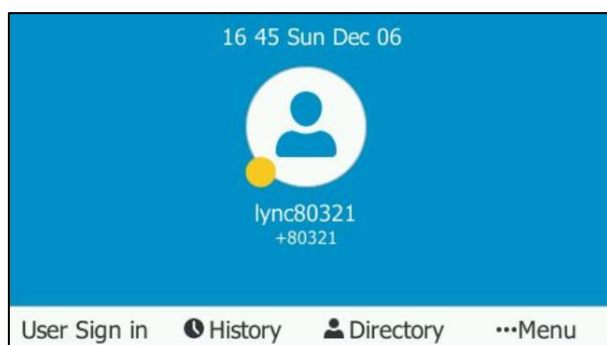

### To switch a CAP account to a Skype for Business account:

1. Press the **User Sign in** soft key when the phone is idle.



2. Press  or  to select the desired sign in method, and then enter your information to sign in a Skype for Business account.

For more information on sign-in, refer to [Sign-in](#) on page 17.



3. Press the **Sign in** soft key.

No matter whether you sign out of the Skype for Business account, the phone will sign into the last CAP account automatically after a period of time. The time is specified on the Skype for Business Server by system administrator.

#### Note

If you switch to another CAP account, your phone will never sign into the last CAP account again.

## Signing out of a Common Area Phone

System administrator can sign out of the CAP account. Once the CAP account is signed out, the phone will not sign into the last CAP account automatically. User can sign into other CAP account or Skype for Business account.

**To sign out of a Common Area Phone:**

1. Press **\*\*\***->**Advanced** (default password: admin or the unlock PIN) ->**CAP Sign Out**.



2. Press **OK** or the **CAP sign out** soft key.

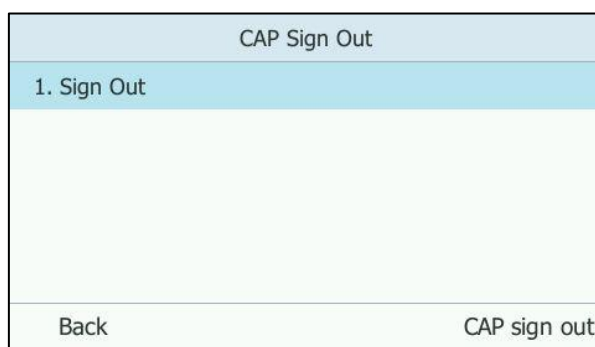

The current CAP account will sign out.

## Better Together over Ethernet

---

Better Together over Ethernet (BToE) feature enables the SIP-T46G IP phone to interoperate with the Skype for Business client for third party call control. You can place, answer, and hold audio calls from your SIP-T46G IP phone and the Skype for Business client on your PC simultaneously. In order to use BToE, you need to download and install the Yealink BToE Connector application on your PC.

This chapter explains how to download and install the Yealink BToE Connector application, and how to enable and use BToE feature. Topics include:

- [Getting Started with Better Together over Ethernet](#)
- [Installing the Yealink Better Together over Ethernet Connector](#)
- [Enabling Better Together over Ethernet](#)
- [Using Better Together over Ethernet](#)

If you require additional information or assistance, contact your system administrator.

## Getting Started with Better Together over Ethernet

To enable and use BToE, you need to ensure the following requirements are available on your PC:

- Skype for Business client
- A registered Skype for Business user  
Obtain a Skype for Business user and sign-in information from your system administrator.
- Running Windows Vista or later
- Administrator privileges are needed to install the Yealink BToE Connector

## Installing the Yealink Better Together over Ethernet Connector

The Yealink BToE Connector enables you to use BToE feature on your Skype for Business client and SIP-T46G IP phone. You need to download, install, and start the Yealink BToE Connector application before enabling BToE and pairing your phone with the Skype for Business client. This section shows you how to download and install the Yealink BToE Connector application on your PC.

Ask the Yealink FAE or reseller for the BToE Connector application, or download it online:

<http://www.yealink.com/DocumentDownload.aspx?CatId=142&flag=142>.

**To install the Yealink BToE Connector on your PC:**

1. Unzip the downloaded file.
2. Double click the installation application **Yealink BToE Connector**.

A User Account Control dialog is displayed as below:

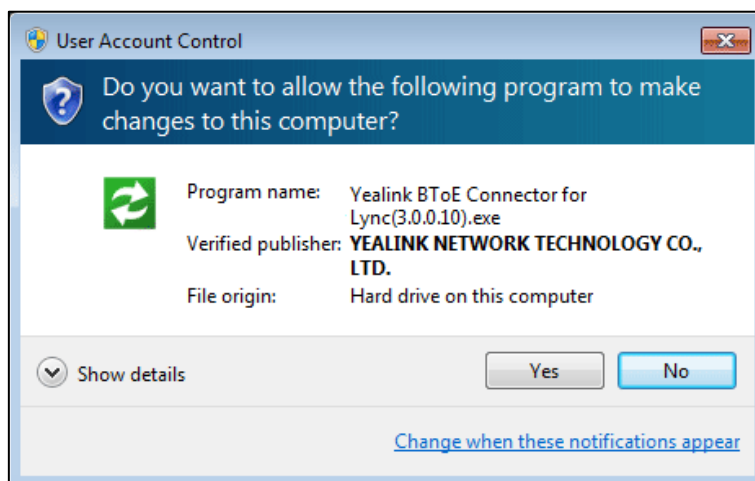

3. Ensure that the dialog lists **YEALINK NETWORK TECHNOLOGY CO., LTD.** as the verified publisher and click **Yes**.

If the YEALINK NETWORK TECHNOLOGY CO., LTD. is not listed as the publisher, click **No** and download the application again from the Yealink website.

The Yealink BToE Connector Setup Wizard is displayed as below:

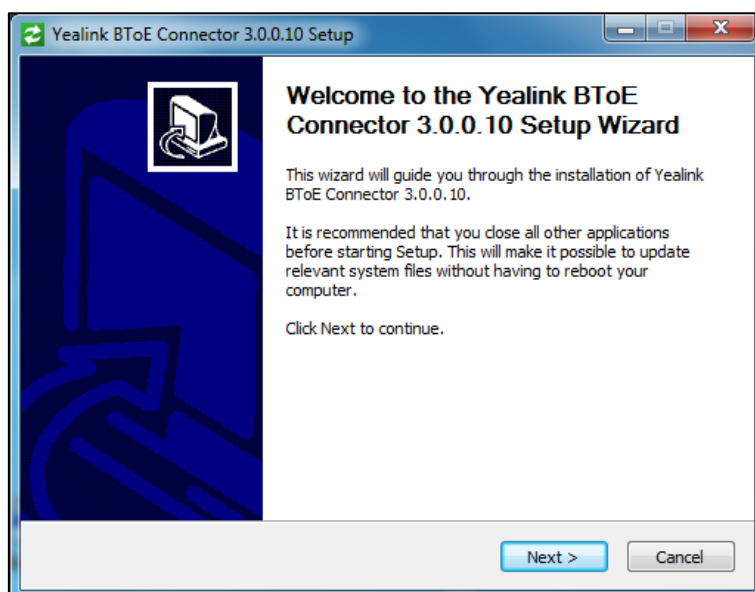

4. Click **Next** to continue.

The License Agreement dialog is displayed as below:

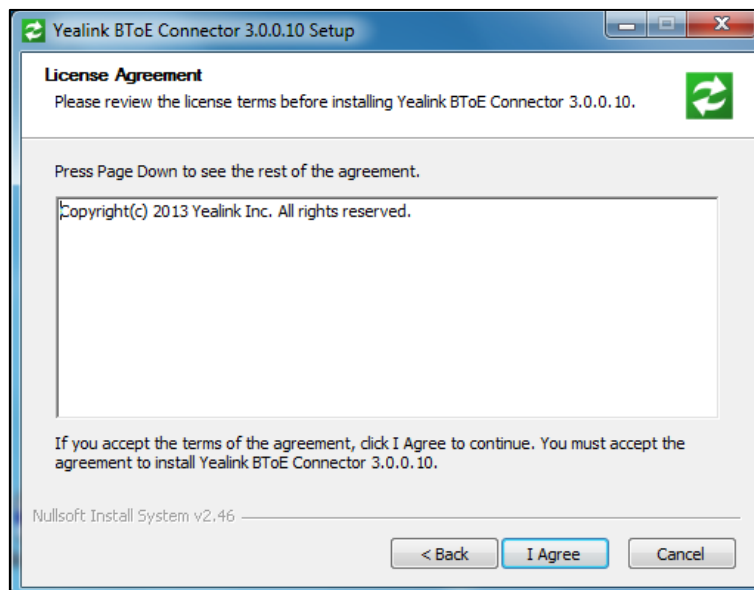

5. Click **I Agree** to accept the agreement.

The Yealink BToE Connector Setup Wizard is displayed as below:

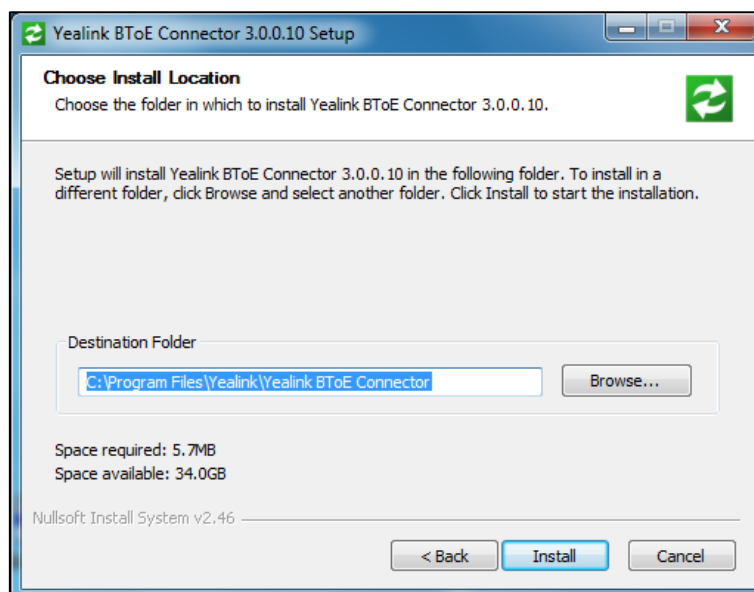

6. Click **Browse...** to select an installation folder and click **Install** to begin the installation.

By default, the Yealink BToE Connector application is installed in the directory C:\Program Files\Yealink\Yealink BToE Connector\.

A status bar showing the Yealink BToE Connector installation's progress is displayed as below:

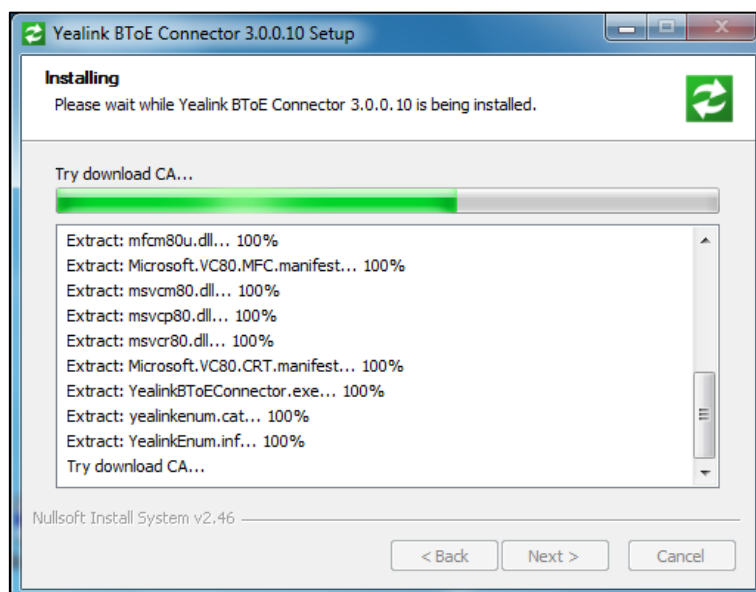

The installation may take several minutes. A Windows Security is displayed as below during installation:

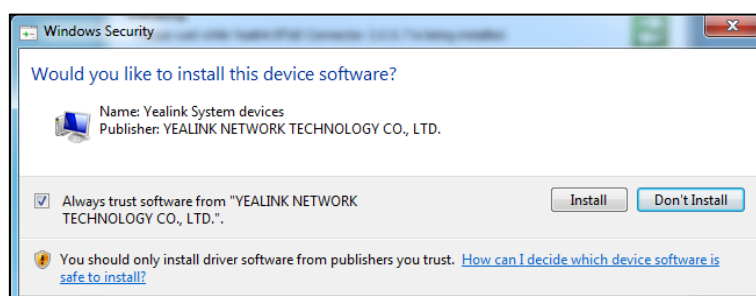

7. Click **Always trust software from “YEALINK NETWORK TECHNOLOFY CO., LTD”**, and then click **Install** to install the driver software.

After the software has completed installing, a dialog is displayed as below:

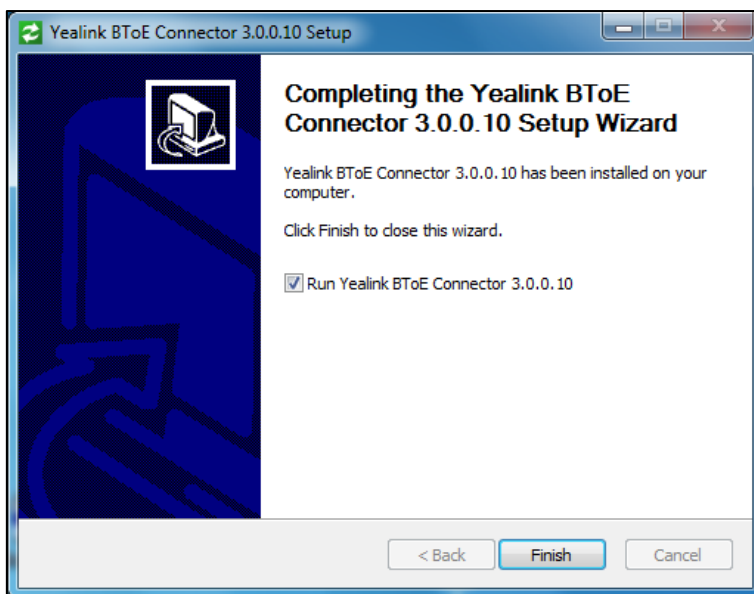

The checkbox of **Run Yealink BToE Connector 3.0.0.10** is checked by default, as shown above. If the checkbox of **Run Yealink BToE Connector 3.0.0.10** is not checked, you need to start the Yealink BToE Connector manually.

8. Click **Finish**.

The Yealink BToE Connector starts on your PC automatically, the following window will appear:



**To set up the Yealink BToE connector:**

Right-click  in the system tray, you can do the following:



- Click **Show/Hide(S)**, the Yealink BToE Connector interface will be shown or hidden.
- Click **Pair & Sign in(G)**, you can pair your phone with your Skype for Business client.
- Click **Sign in by Lync(L)**, after your phone pairs with Skype for Business client successfully, but the Skype for Business client and phone using two different accounts, you can use the BToE sign-in to make the phone sign in using the same account as Skype for Business client. For more information, refer to [BToE Sign-in](#) on page 181.
- Click **Settings(P)**, you can set up the Yealink BToE Connector, and then click **OK** to save.

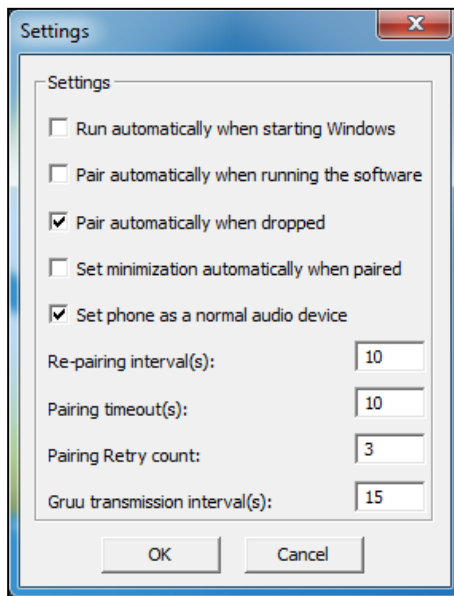

- Click **About(A)**, you can view the information of Yealink BToE Connector.
- Click **Exit(E)**, you can close the software.

## Enabling Better Together over Ethernet

Before you can use BToE, you need to pair your phone with your Skype for Business



client to enable BToE. This section provides information on how to pair your phone with your Skype for Business client.

## Configuring BToE

You should enable the BToE feature on the phone, and then enter the correct pairing PIN to complete pairing your phone with Skype for Business client. This feature is used to protect your information security so that your phone will not be paired by anyone.

**To configure BToE feature via phone user interface:**

1. Press **...** -> **Advanced** (default password: admin) -> **BToE**.
2. Press **◀**, **▶** or the **Switch** soft key to select **Enabled** from the **BToE** field.
3. Enter the pairing PIN in the **BTOE pairing PIN** field.

The pairing PIN consists of 4-6 digits, the default PIN is "0000".

BToE	
1. BToE:	Enabled < >
2. BTOE Paring Status:	Unpaired(Not signed in)
3. BTOE Pairing Pin:	<input type="text" value="0000"/>
Back	123 Delete Save

4. Press **Save** soft key to accept the change or the **Back** soft key to cancel.

BToE is configurable via web user interface at the path: **Settings->BToE->BToE pairing PIN**.

## Paired Status

After a Skype for Business user signs into the Skype for Business Server on your Skype for Business client, you can pair your phone with your Skype for Business client to enable BToE. Before you pair your phone with the Skype for Business client, you need to be familiar with the following paired status:

- **Not Paired:** Your phone and your Skype for Business client are not paired.

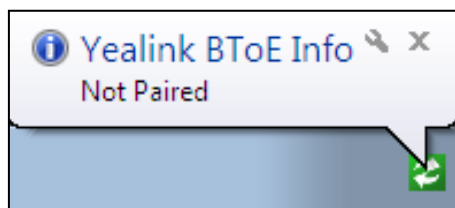

- **Paired (Sign Out):** Your phone and your Skype for Business client are paired but fail to sign in. The reason may be the user signing on your phone differs from the one signing on the Skype for Business client, or there is no user signing on your phone.

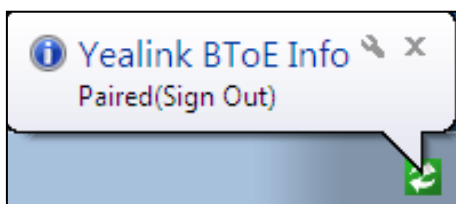

- **Paired (Sign In):** Your phone and your Skype for Business client are paired and sign in successfully. This means the Skype for Business user signing on the phone is the same as the one signing on the Skype for Business client.

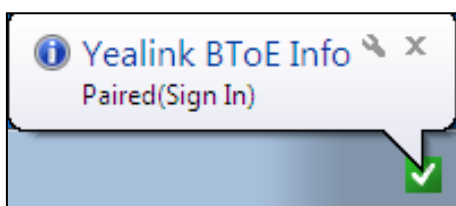

**To view the paired status on PC:**

1. Double left-click on BToE icon.
2. View the BToE paired status in the **BToE Status** field.



To view the paired status via phone user interface:

1. Press ... ->**Advanced** (default password: admin) ->**BToE**.
2. View the BToE paired status in the **BTOE pairing status** field.

BToE	
1. BToE:	Enabled < >
2. BTOE Paring Status:	Unpaired(Not signed in)
3. BTOE Pairing Pin:	<input type="text" value="0000"/>
<div style="display: flex; justify-content: space-between;"> <span>Back</span> <span>Save</span> </div>	

## Pairing your phone with Skype for Business client

Ensure that the Yealink BToE Connector application is running on your PC. To pair your phone with your Skype for Business client, do one of the following:

- a) If connect your PC to the PC port on IP phone using an Ethernet cable (network of the PC will be provided by the PC port of the phone).
  1. As the checkbox of **Auto** is checked by default, the IP address of your phone is automatically filled in the **Phone IP** field.
  2. Enter the BToE pairing PIN in the **PIN** field.

3. Click **Pair**.
- b) If your PC is not connected to the PC port on the phone, do the following:
  1. Uncheck the **Auto** checkbox.

2. Enter the IP address of the phone that you want to pair in the **Phone IP** field.
3. Enter the BToE pairing PIN in the **PIN** field.

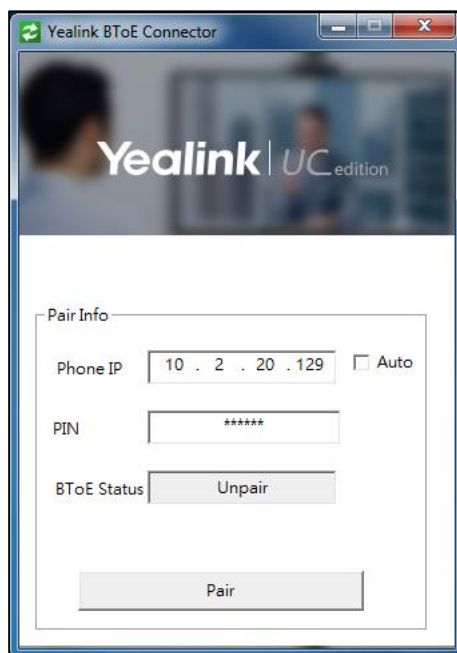

4. Click **Pair**.

If it is the first time to pair your phone with Skype for Business client, the PC starts to install device driver software, you can click  to view the status.

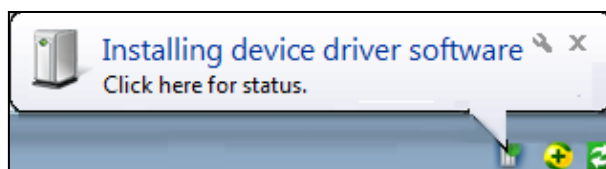

After installation, the Yealink BToE Connector and the application driver run successfully, a prompt message is displayed in the system tray:

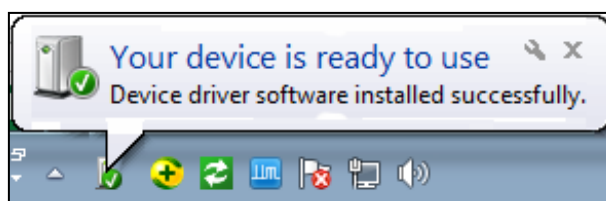

The Yealink BToE connector interface is displayed as below when your phone and the Skype for Business client are paired successfully:



The phone LCD displays the prompts “BToE Connect Succeed”.

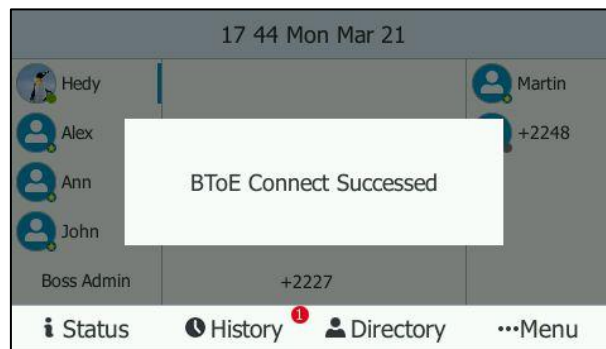

**Note** After a successful pairing, you don't need to enter the BToE pairing PIN next time unless the PIN is changed.

## BToE Sign-in

After your phone pairs with Skype for Business client successfully, you can sign into your phone using BToE sign-in method. As a result, you will sign into the Skype for Business client and phone using same account.

**To sign into the Skype for Business Server using BToE Sign-in method:**

- a) If the Skype for Business client is already logged on, but the phone is not:
  - 1. A logon dialog will pop up on your PC to prompt you to enter the logon password.

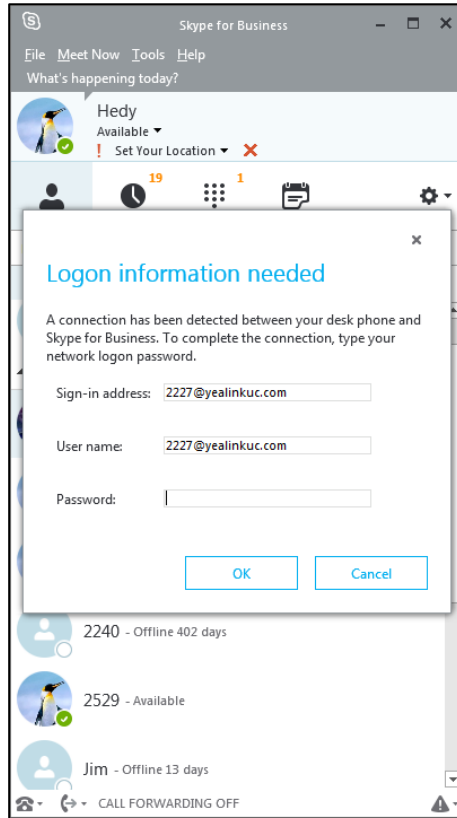

If you click **Cancel**, the logon dialog will disappear. You can do one of the following to pop up the logon dialog again:

- Right-click on  on PC, and then select **Sign in by Lync(L)**.
- Press **Sign in** soft key, select **sign in via SFB Client**, and then press the **Sign in** soft key.

- 2. Enter the password in the **Password** field.
- 3. Click **OK**.

The phone will sign in the same account as Skype for Business client automatically.

- b) If you sign into the Skype for Business client and phone using two different accounts before pairing:

1. Right-click on  , and then select **Sign in by Lync(L)**.



A logon dialog will pop up on your PC to prompt you to enter the logon password.

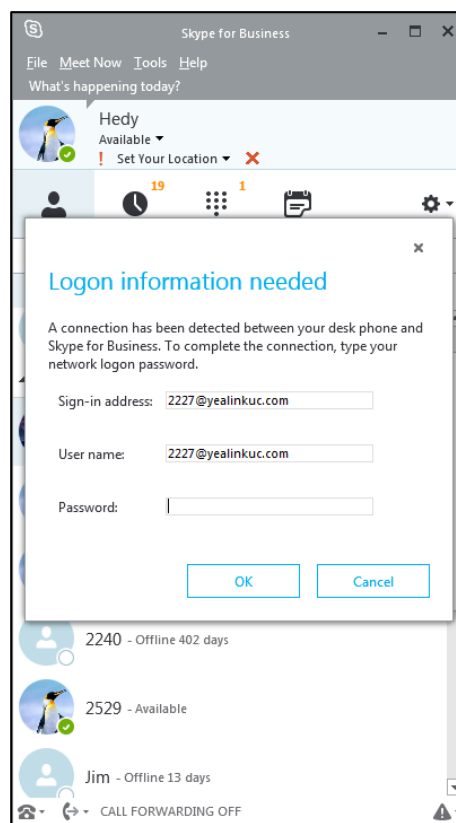

2. Enter the password in the **Password** field.
3. Click **OK**.

The phone will sign in the same account as Skype for Business client automatically.

- c) If you already sign into the Skype for Business client and phone using same account before pairing:

Your phone can interoperate with Skype for Business client for third-party call control directly.

If the Skype for Business Server is configured to forcibly lock the phone. You need to configure an unlock PIN at the initial sign-in. For more information, refer to Phone Lock on

page 46.

## Setting the IP Phone as Primary Device

Before using BToE feature, you need to ensure that your phone is set as the primary device in your the Skype for Business client on your PC.

To select the IP phone as your primary device:

1. In Skype for Business client, click  . As shown below:

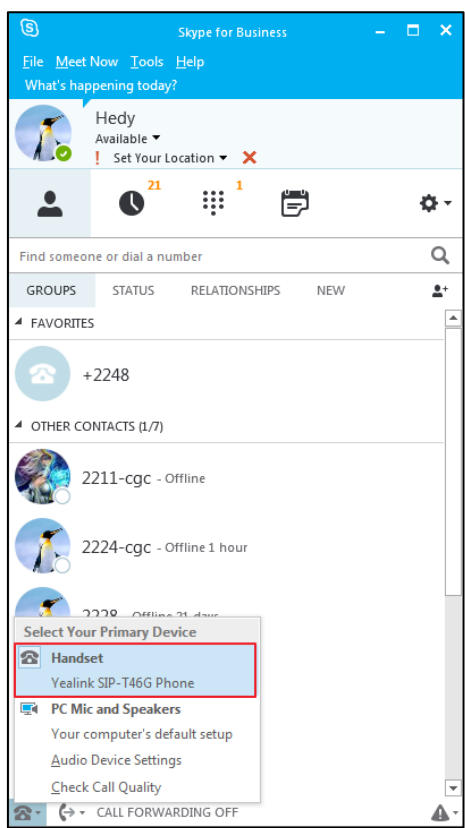

2. Select **Yealink SIP-T46G Phone** as your primary device.  
After finishing the above steps, you can use BToE feature.

### Note

If **Yealink SIP-T46G Phone** is not selected as your primary device, you will not be able to use BToE feature (for example, calls made on the Skype for Business client will not be displayed on the phone).

## Using Better Together over Ethernet

This section provides information on how to use BToE on your phone and the Skype for Business client.



BToE enables you to call Skype for Business contacts using your Skype for Business client



while providing you with quality audio through your phone. After BToE is enabled, you can answer, place, hold and resume calls with your Skype for Business contacts on your phone and the Skype for Business client on your PC simultaneously.

#### To place a call:

Do one of the following:

- Select a contact or enter the phone number, then press , or you can press the avatar of the contact in **Favorites** screen.
- Hover the mouse over the avatar of the contact, and then click  in your Skype for Business client.

Your phone and the client are in the Calling state.

#### To answer a call:

When you receive an incoming call, the incoming call information is displayed on your phone and your Skype for Business client.





Do one of the following:

- Press  or press  on your phone.
- Click  in your Skype for Business client.

The incoming call is answered both on the phone and the Skype for Business client. The established call uses the phone as audio device by default.

#### To place a call on hold:





Do one of the following:

- Press  or press  on your phone.
- Hover your cursor over the icon  in your Skype for Business conversation window to display the control panel, and then click  in your Skype for Business client.

The call is placed on hold on your phone and your Skype for Business client.

#### To resume a held call:

Do one of the following:

- Press  or press  on your phone.
- Hover your cursor over the icon  in you Skype for Business conversation window to display the control panel, and then click  in your Skype for Business client.

The call is resumed on your phone and your Skype for Business client.

**To change the audio device during a call in the Skype for Business client:**

When the phone and Skype for Business client have a call, and the phone speaker is used as audio device, you may want to change the audio device during a call. Do the following:

1. Hover your cursor over the icon  in Skype for Business conversation window to display the control panel.
2. Click .
3. Click the desired audio device.

- Click **PC MIC and Speakers** to move the call audio from your phone to your PC.

The call on the phone will be released. The Skype for Business client uses the selected audio device to continue the call.

- Click **Handset Yealink SIP-T46G Ph...** to move the call audio from your PC to your phone.

# EXP40 Expansion Module

The Yealink EXP40 is ideal for receptionists, administrative assistants, call center agents, power-users, and executives who need to place a large volume of calls on a regular basis. When your SIP-T46G is registered with a Skype for Business Server, you can assign Skype for Business contacts to line keys on your EXP40, so that you can quickly call contact by pressing the corresponding line key. You can also monitor your Skype for Business contacts' presence status from your expansion module. For more information on contact's presence, refer to [Changing Presence Status](#) on page 25.

This chapter explains how to use the EXP40. Topics include:

- [Connecting the EXP40](#)
- [EXP40 Hardware Component Instructions](#)
- [Assigning Skype for Business Contacts to the EXP40](#)
- [Using the EXP40](#)

## Connecting the EXP40

If you want to use an EXP40, physically connect the EXP40 to the phone firstly.

The EXP40 applies to SIP-T46G IP phone. To easily connect the EXP40 to the phone, please unplug the phone stand from the SIP-T46G IP phone.

### To unplug the stand from the SIP-T46G IP phone:

1. Unplug the power adapter and Ethernet cable from the IP phone.
2. Unplug the handset attached to the IP phone.
3. Turn the IP phone over and lay it on a non-slip, flat surface.
4. Unplug the stand from the IP phone.

### To connect the EXP40:

1. Turn over the phone and the expansion module, and lay them on a flat, non-slip surface.
2. Connect the EXP40 and the IP phone using the supplied connecting sheet and screws.

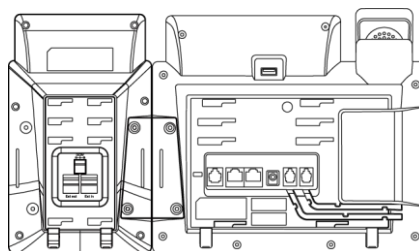

If you want to connect two or more expansion modules, connect two expansion modules as below:

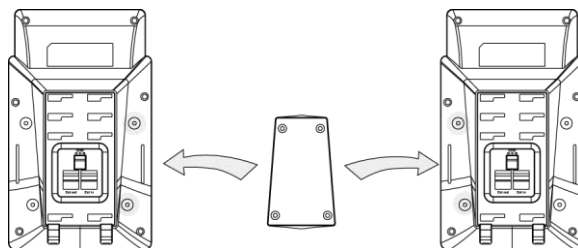

Connecting two expansion modules on a single phone is shown as below:

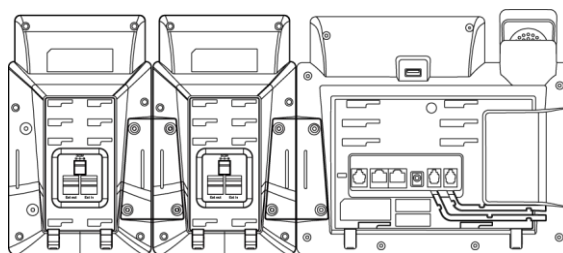

3. Connect the Ext jack of the IP phone and the Ext in jack of the expansion module using one supplied cord.

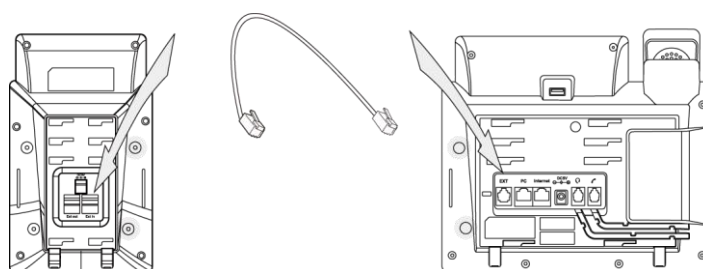

If you connect two expansion modules, connect the Ext out jack of the previous expansion module and the Ext in jack of the second expansion module using another supplied cord.

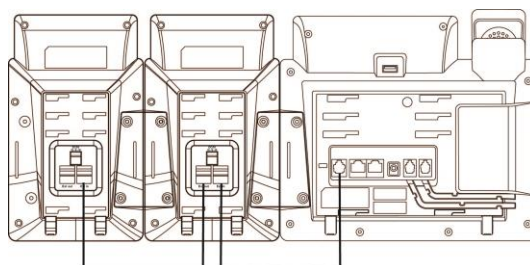

**Note**

Up to six expansion modules can be connected to the SIP-T46G IP phone. If you use more than two expansion modules on a single phone, you need to connect an additional power adapter to any one of the expansion modules.

To attach the stand of the expansion module:

a) Wall mount method (Optional)

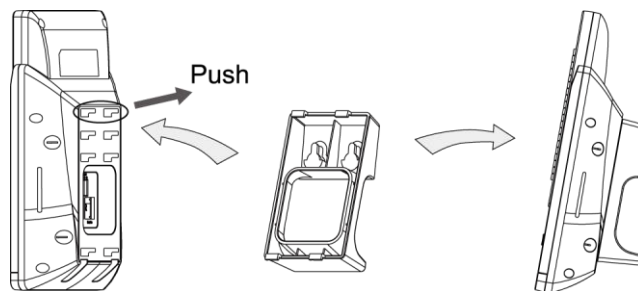

b) Desk mount method

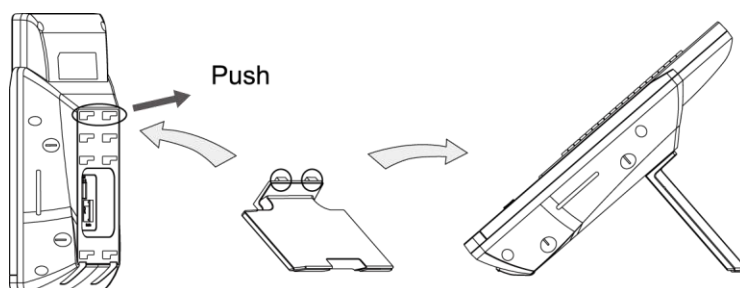

## EXP40 Hardware Component Instructions

The following figure illustrates the features, components, and keys available on the EXP40. The table lists each numbered feature shown in this figure.

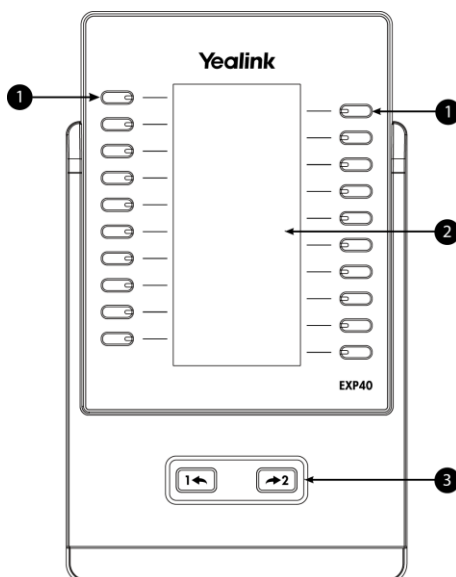

	Item	Description
①	Line Keys	Select available line key contact.
②	LCD Screen	Displays name and presence status of Skype for Business contacts.



	Item	Description
③	Page Keys	Navigates between pages on the expansion module.

## Assigning Skype for Business Contacts to the EXP40

Each EXP40 provides you with 20 lines keys and 2 display pages, supporting a total of 40 lines that you can set up as Skype for Business contacts. You can connect up to 6 EXP40 to your phone to support a maximum of 240 line keys per phone.

You can assign the desired Skype for Business group’s contacts to be displayed on the EXP40. The Skype for Business contacts in the selected group are assigned to line keys on your EXP40.

### To assign Skype for Business contacts to the EXP40:

1. Press **\*\*\*->Basic->Exp Module**.
2. Press  or , or the **Switch** soft key to select the desired Skype for Business group from the **ModuleX** field.

X ranges from 1 to 6. The value of X depends on the sequence number of the connected EXP40.

Null is selected by default, and it means that the EXP40 doesn't display Skype for Business contacts.

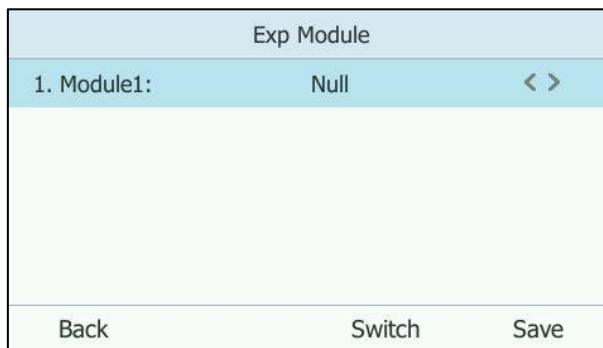

3. Press the **Save** soft key to accept the change or the **Back** soft key to cancel.  
The Skype for Business contacts in the selected group will be displayed on the expansion module.

EXP Module is configurable via web user interface at the path **Settings->EXP Module**.

### Note

Local contacts cannot be displayed on the EXP40. Only Skype for Business contacts can be displayed on the EXP40.

If you connect more than one expansion module to a single phone, and a group A that has more than 40 contacts is assigned to be displayed on the module1, you need to understand the following tips:

- If another group B is assigned to be displayed on the next module, the rest contacts of the group1 will be ignored. The next module only displays contacts in group B.
- If group A is also assigned to be displayed on the next module or no group is assigned to be displayed on the next module, the rest contacts of the group A will be displayed on the next module.

## Using the EXP40

When your phone is connected to the EXP40, you can assign Skype for Business contacts to line keys on your EXP40. You can quickly call Skype for Business contacts, initiate a conference call or transfer a call by pressing the corresponding line key on the expansion module. You can also view your Skype for Business contacts' presence status and name from your expansion module.

## Placing a Call Using the EXP40

You can place a call or add a new call quickly using the line keys on the EXP40.

### To place a call when the phone is idle using the EXP40:

1. Press a line key corresponding to the Skype for Business contact you want to call.

You can press the page key to turn pages.

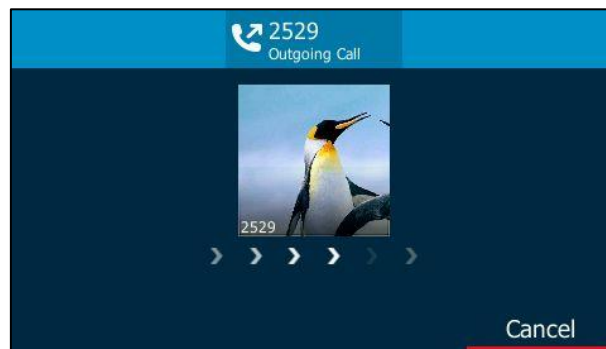

### To add a new call during a call using the EXP40:

1. Press a line key corresponding to the Skype for Business contact you want to add.

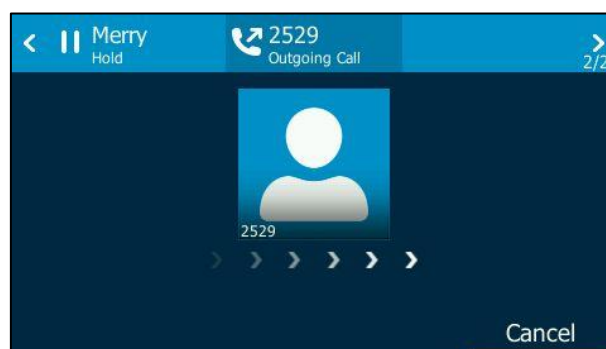

The call will be placed directly.

## Initiating a Conference Call Using the EXP40

You can initiate a conference call quickly using the line keys on the EXP40.

**To initiate a conference call using the EXP40:**

1. Press the **Add** soft key during a call.

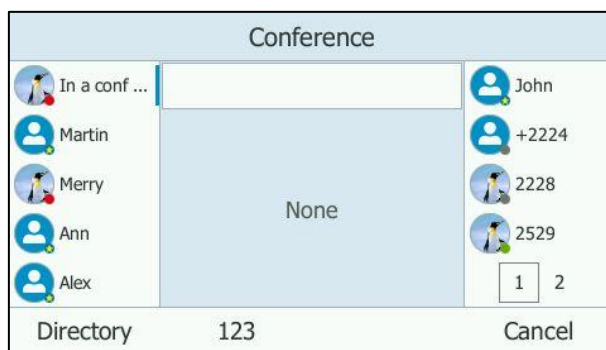

2. Press a line key corresponding to the Skype for Business contact you want to call.  
You can press the page key to turn pages.



3. After the party answers the call, three parties are now joined in the conference.

## Transferring a Call Using the EXP40

You can perform an attended transfer quickly using the line keys on the EXP40. But you can't perform a blind transfer using the EXP40.



**To perform an attended transfer during a call:**

1. Press  or the **Transfer** soft key during a call.



2. Press a line key corresponding to the Skype for Business contact you want to transfer to.

You can press the page key to turn pages.

3. After the party answers the call, press  or the **Transfer** soft key to complete the transfer.

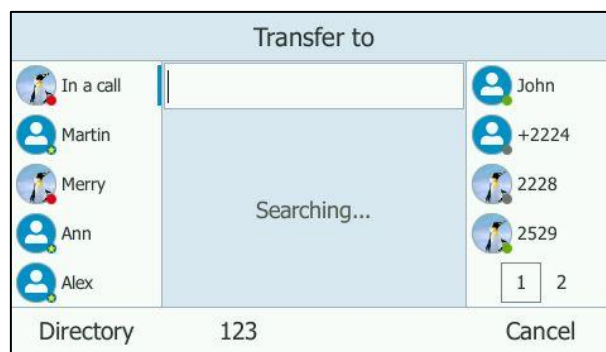

The call is connected to the number to which you are transferring



# Troubleshooting

---

This chapter provides general troubleshooting information to help you solve the problems you might encounter when using your SIP-T T46G IP phone.

If you require additional information or assistance with your new phone, contact your system administrator.

## Troubleshooting Solutions

### Why is the phone LCD screen blank?

- Ensure that the phone is properly plugged into a functional AC outlet.
- Ensure that the phone is plugged into a socket controlled by a switch that is on.
- If the phone is plugged into a power strip, try to plug it directly into a wall outlet instead.
- If the phone is powered from PoE, ensure you use a PoE-compliant switch or hub.

### Why does the phone display “Network unavailable”?

- Ensure that the Ethernet cable is plugged into the Internet port on the phone and the Ethernet cable is not loose.
- Ensure that the switch or hub in your network is operational.
- Contact your system administrator for more information.

### Why doesn't the phone display time and date correctly?

Check if you have configured the phone to obtain the time and date from the SNTP server automatically. If the phone fails to connect the SNTP server, contact your system administrator for more information. You can also configure the time and date manually. For more information, refer to [Time & Date](#) on page 42.

### How can I find the basic information of the phone?

Press the **OK** soft key to check the basic information of the phone when the phone is idle, such as the IP address and firmware version. For more basic information, refer to [Phone Status](#) on page 35.

### How to obtain the MAC address of a phone when the phone is not powered on?

Three ways to obtain the MAC address of a phone:

- You can ask your supplier for shipping information sheet which includes MAC

addresses according to the corresponding PO (Purchase Order).

- You can find the MAC address on the label of the carton box.
- You can also find the MAC address from the phone's bar code on the back of the phone.

#### Why can't I sign into the Skype for Business Server on the phone?

- Check your phone is properly connected to the switch or hub.
- Validate your domain name and sign-in information are correct.
- Ensure that DNS address is properly configured on the phone, or DHCP is configured to provide DNS address as part of DHCP response.

#### What's the main difference between PIN Authentication and User Sign in method?

The sign-in screen appears after phone initialization by default. User Sign in uses the user name, sign-in address and password to sign in. PIN Authentication uses the user's phone number (or extension) and PIN to sign in. They are available on the phone user interface or web user interface.

#### How to check if the application driver of the Yealink BToE Connector is installed on the PC?

Do one of the following:

- After installation, if the Yealink BToE Connector and the application driver run successfully, the notification area of the system tray will prompt: **Device driver software installed successfully.**

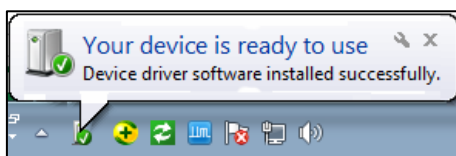

- Do the following steps to check if the application driver is installed (take the Windows 2007 operating system as an example):

1. Click the **Start** button .
2. Click **Control Panel->Device Manager.**
3. Double click **System devices.**
4. Check if the driver **Yealink BToE Enumerator** is displayed.

If Yealink BToE Enumerator is not displayed, reinstall the Yealink BToE Connector application, and ensure that the application driver is installed during the installation process.

#### How to cancel auto-start for the Yealink BToE connector?

1. Right-click  in the system tray.

2. Click **Settings(P)**.
3. Uncheck **Run automatically when starting Windows** to cancel the auto-start feature.  
As shown next:

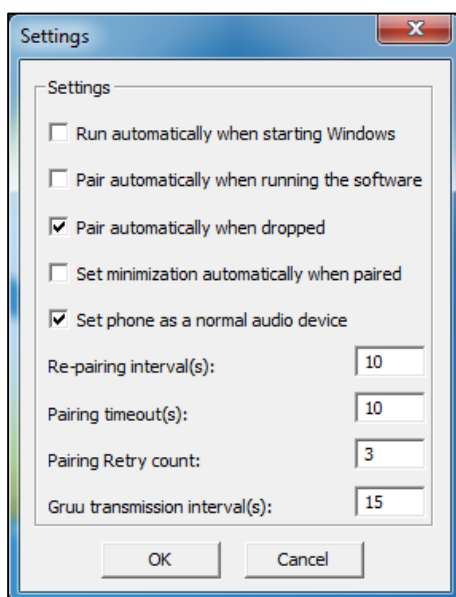

**To uninstall the Yealink BToE connector:**

1. Click the **Start** button .
2. Click **All Programs->Yealink BToE Connector->Uninstall**.

The PC prompts "Are you sure to remove Yealink BToE Connector 3.0.0.10 and other component completely?":

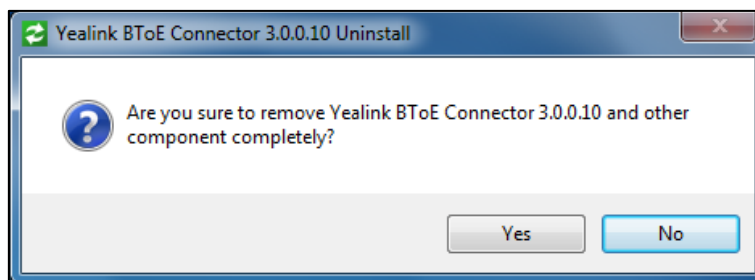

3. Click **Yes** to uninstall the Yealink BToE connector.

A progress bar showing the Yealink BToE Connector uninstallation's progress is displayed as below:

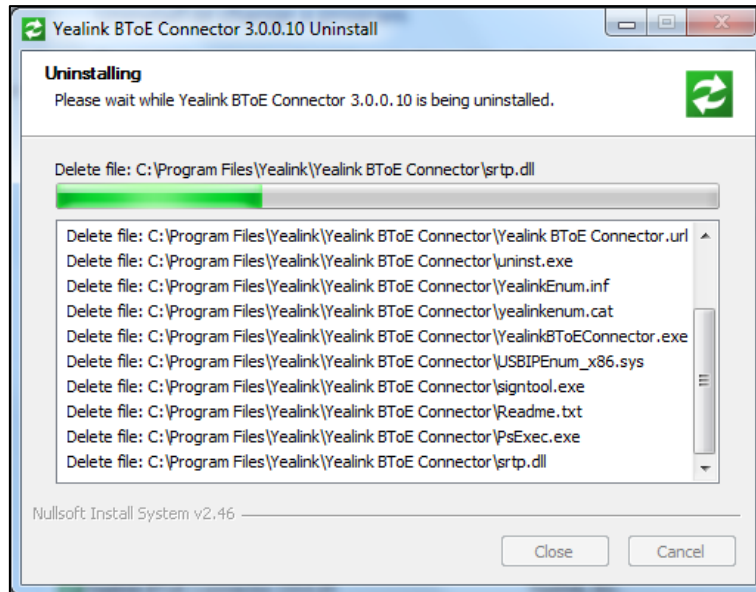

The uninstallation may take several minutes. A dialog is displayed as below:

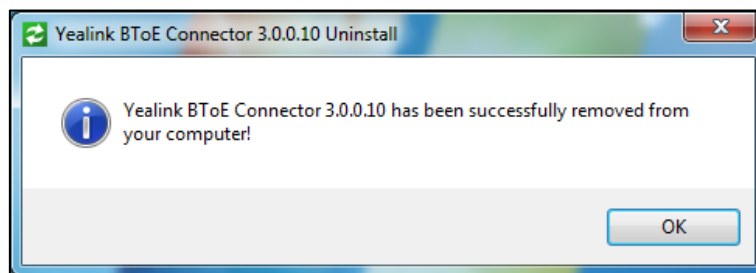

4. Click **OK** to finish the uninstallation.

#### Why can't the phone pair with my Skype for Business client?

- Ensure that your Skype for Business client is installed on your PC and a Skype for Business user signs into Skype for Business Server successfully.
- Ensure that the user signing on the phone is the same as the one signing on the Skype for Business client.
- Re-pair the phone and Skype for Business client manually.
- Ensure that Yealink BToE Connector and application driver are successfully installed on your PC, and both of them start successfully. If the phone still cannot pair with the Skype for Business client, reboot the PC.
- After reboot, if the phone still cannot pair with the Skype for Business client, uninstall the Yealink BToE Connector and application driver, and then reinstall them.
- Ensure that Yealink BToE Connector is an allowed program in your system's firewall

on your PC.

#### Why doesn't the phone display the Calendar menu?

- Ensure that your phone has signed in successfully.

#### Why doesn't the Skype conference, appointment, meeting or event set up in outlook display on the Calendar menu?

- Ensure that you sign into the phone using [User Sign-in](#), [Device Pairing for Online](#) or [BToE Sign-in](#) method.

#### Why can't I get a dial tone?

- Check for any loose connections and that the phone has been installed properly. For the installation instructions, refer to [Phone Installation](#) on page 14.
- Switch between the Handset, Headset (if present) or Hands-Free Speakerphone to check whether the dial tone is present for one of the audio modes.

If the dial tone exists on another audio mode, connect a different handset or headset to isolate the problem.

#### Why doesn't the phone ring?

Check the ringer volume on the phone. To adjust the ringer volume setting, press the Volume key when the phone is on-hook and idle. For more information, refer to [Volume](#) on page 48.

#### Why can't I receive calls?

- Check that whether your status is DND mode, if it is, you should reset status. Refer to [Changing Presence Status](#) on page 25.
- Check that whether call forward is disabled on the phone. Refer to [Call Forward](#) on page 112.

#### Why doesn't my handset work?

- Check that the headset cord is fully connected to the headset jack on the phone. Refer to [Phone Installation](#) on page 14.
- Check that whether the headset volume is adjusted to an appropriate level. Refer to [Volume](#) on page 48.

### Why does the phone play a tone when there is a call on hold? How to disable it?

When there is a call on hold, the phone will play a hold tone every 30 seconds. Play hold tone is enabled by default. Play hold tone and the interval of playing a hold tone are configurable via web user interface only.

To configure play hold tone and play hold tone delay via web user interface:

1. Click on **Features->General Information**.
2. Select **Enabled** or **Disabled** from the pull-down list of **Play Hold Tone**.
3. Enter the desired time (in seconds) in the **Play Hold Tone Delay** field.

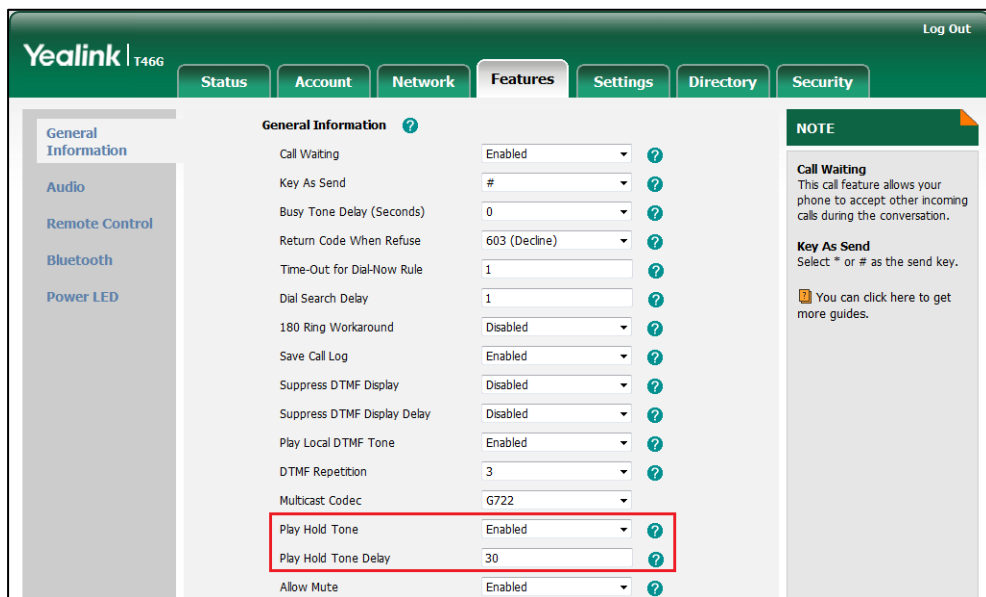

4. Click **Confirm** to accept the change.

### How to export PCAP trace?

We may need you to provide a PCAP trace to help analyze your problem.

To export a PCAP trace via web user interface:

1. Click on **Settings->Configuration**.
2. Click **Start** to begin recording signal traffic.
3. Recreate the error to be documented in the trace.
4. Click **Stop** to end recording.



- Click **Export** to open file download window, and then save the file to your local system.

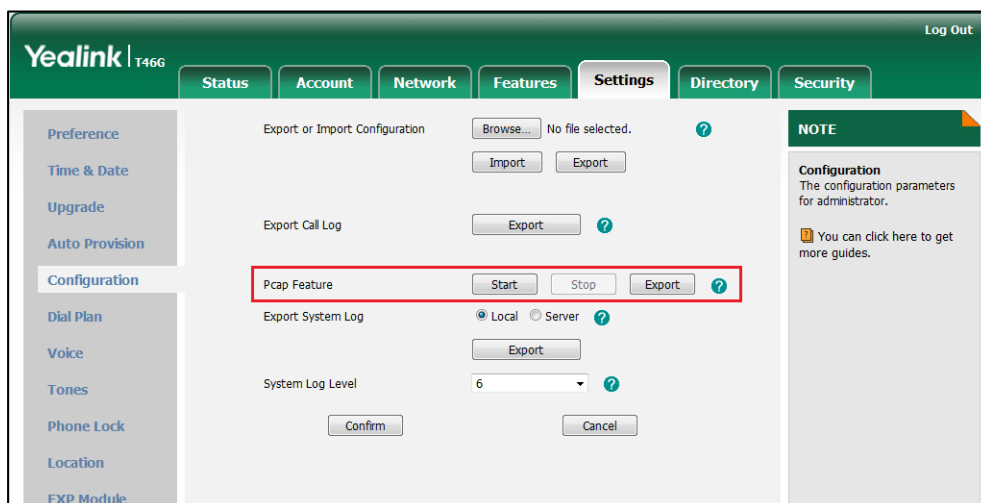

### How to export system log?

The log files are Yealink specific debug files which may be requested by the Yealink support organization. If you need technical support, you can export the log files to the Skype for Business Server, a local system or a syslog server. You can also specify the severity level of the log to be reported to a log file. The default system log level is "3".

#### a) Exporting the Log File to the Skype for Business Server

You can upload system log to the Skype for Business Server via phone user interface only.

**To export a log file to the Skype for Business Server via the phone user interface:**

- Press **...** ->**Basic**->**Log Upload**.

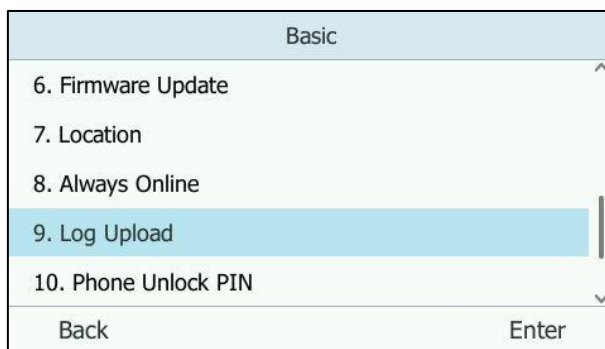

2. Press the **Upload** soft key.



A dialog box pops up to prompt "Log Upload Success!".

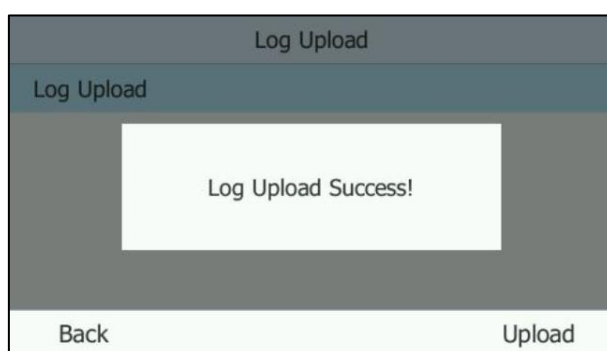

**b) Exporting the Log File to the Local System**

To export a log file to the local system via web user interface:

1. Click on **Settings->Configuration**.
2. Mark the **Local** radio box in the **Export System Log** field.
3. Click **Export** to open file download window, and then save the file to your local system.

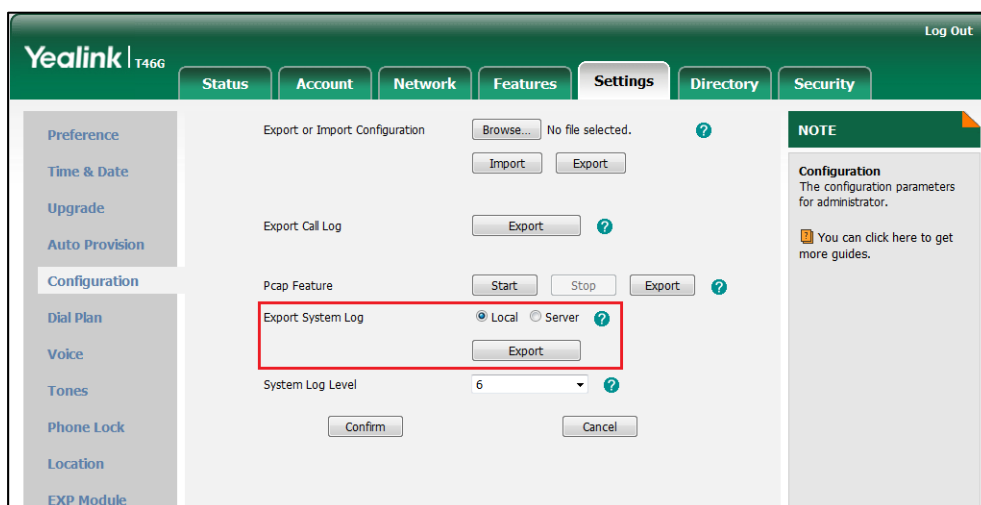

A log file named **syslog.tar** is successfully exported to your local system.

### c) Exporting the Log File to a Syslog Server

To configure the phone to export the system log to a syslog server via web user interface:

1. Click on **Settings->Configuration**.
2. Mark the **Server** radio box in the **Export System Log** field.
3. Enter the IP address or domain name of the syslog server in the **Server Name** field.

For example, the IP address of your syslog server is 192.168.1.100.

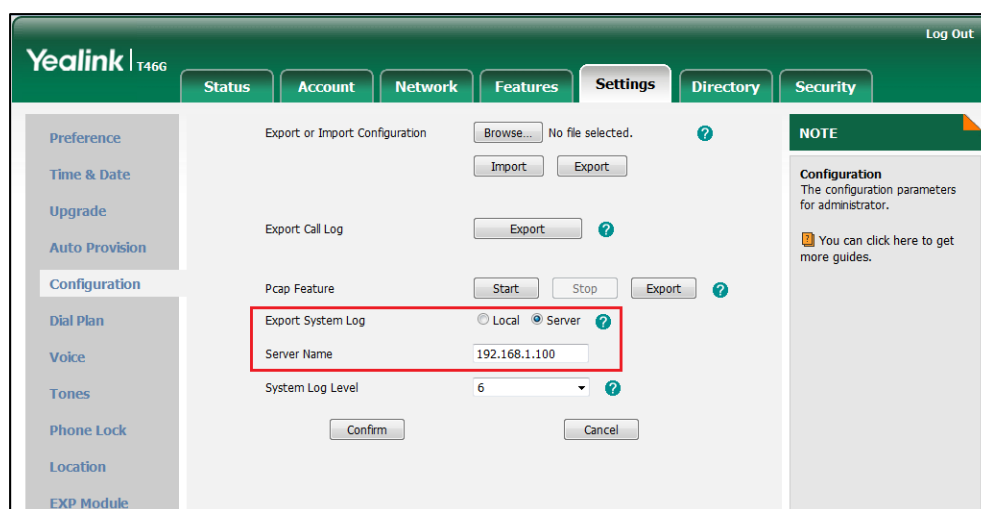

4. Click **Confirm** to accept the change.  
A dialog box pops up to prompt "Do you want to restart your machine?". The configuration will take effect after a reboot.
5. Click **OK** to reboot the phone.  
The system log will be exported successfully to the desired syslog server (192.168.1.100) after a reboot.

### How to export/import phone configurations?

We may need you to provide your phone configurations to help analyze your problem. In some instances, you may need to import configurations to your phone.

**How to export your phone configurations via web user interface:**

1. Click on **Settings->Configuration**.
2. Click **Export** to open file download window, and then save the file to your local system.

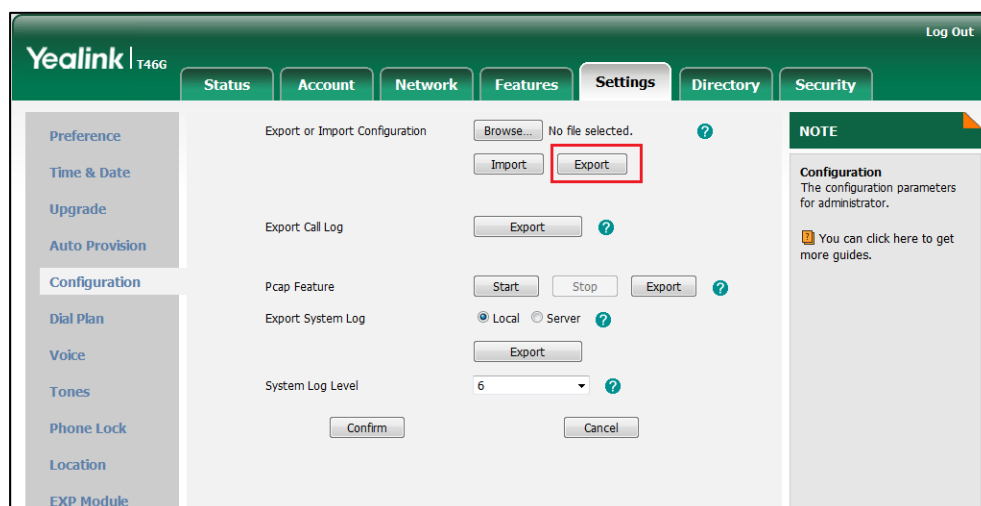
**To import phone configurations via web user interface:**

1. Click on **Settings->Configuration**.
2. Click **Browse...** to locate a configuration file from your local system.
3. Click **Import** to import the configuration file.

**Note** The file format of configuration file must be “.bin”.

**How to export call log?**

User can access call logs by downloading them to the local system for diagnosis purpose.

To export the call log via web user interface:

1. Click on **Settings->Configuration**.
2. Click **Export** to open file download window, and then save the file to your local system.

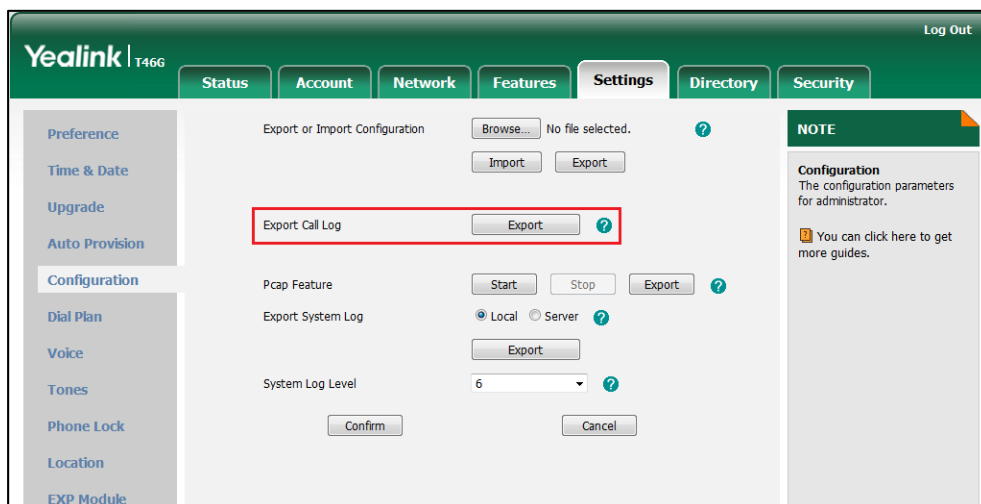

How to change the user password?

To change the user password via web user interface:

1. Click on **Security->Password**.
2. Select **user** from the pull-down list of **User Type**.
3. Enter the new user password in the **New Password** field and **Confirm Password** field.

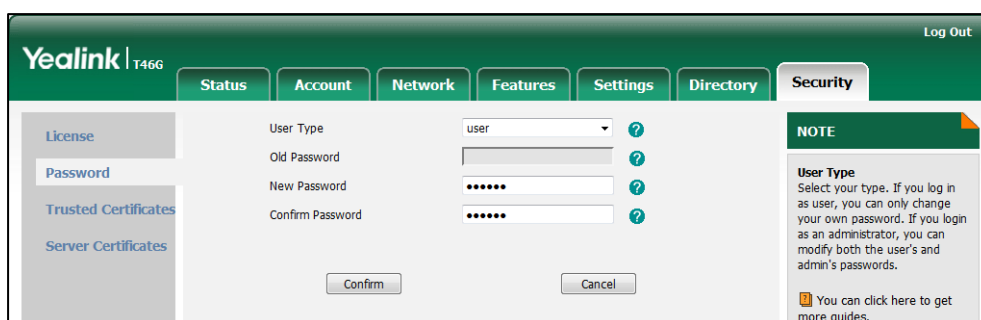

4. Click **Confirm** to accept the change.

**Note**

If signing into the web user interface of the phone with the User Sign in, you need to enter the current user password in the **Old Password** field.

User password is configurable via web user interface only.

### How to reboot the phone?

#### To reboot the phone via phone user interface:

1. Press **...** -> **Advanced** (default password: admin).
2. Press **▲** or **▼** to scroll to **Reboot**, and then press the **Enter** soft key.



3. Press the **Reboot** soft key.



The LCD screen prompts "Reboot the phone?".

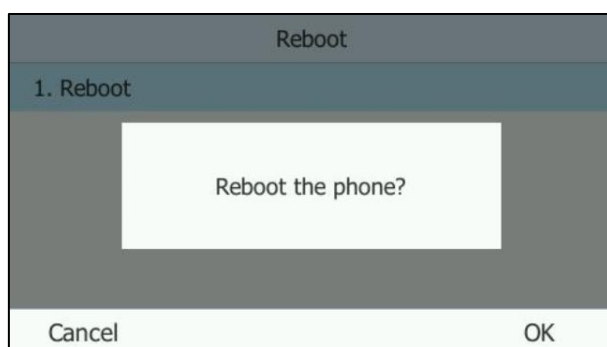

4. Press the **OK** soft key to reboot the phone.

**Note** Any reboot of your phone may take a few minutes.

## How to upgrade firmware?

To upgrade firmware via web user interface:

1. Click on **Settings->Upgrade**.
2. Click **Browse...** to locate the firmware from your local system.

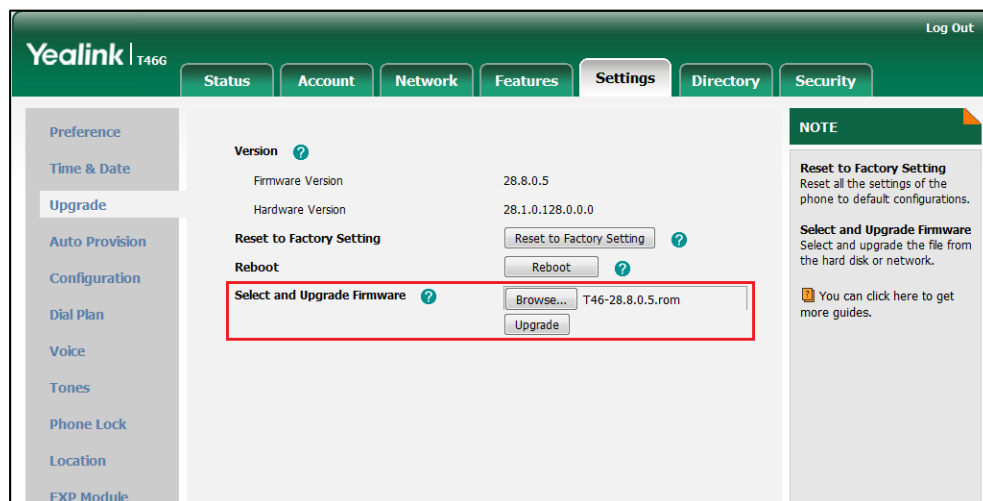

3. Click **Upgrade** to upgrade the firmware.

The browser pops up the dialog box "Firmware of the SIP phone will be updated. It will take 5 minutes to complete. Please don't power off!".

4. Click **OK** to confirm upgrading.

SIP-T46G phones can be also upgraded from the Skype for Business Server. For more information on how to upgrade the SIP-T46G phone from the Skype for Business Server, refer to [Updating Phone Firmware from Microsoft Skype for Business Server](#).

## How to reset your phone?

Reset the phone to factory configurations after you have tried almost all troubleshooting suggestions but do not solve the problem.

Three ways to reset the phone:

- **Full Reset:** All configurations and userdata on the phone will be reset.
- **Configuration Reset:** All configurations (e.g., account, call history) set on the phone will be reset.
- **Userdata Reset:** All custom data (e.g., ring tone) set on the phone will be reset.

Contact your system administrator before resetting the phone.

To reset the phone via phone user interface:

1. Press **\*\*\* ->Advanced** (default password: admin) ->**Reset to Factory**.
2. Press **◀** or **▶**, or the **Switch** soft key to select the desired reset option from **Reset Option** field.

3. Press the **Save** soft key.

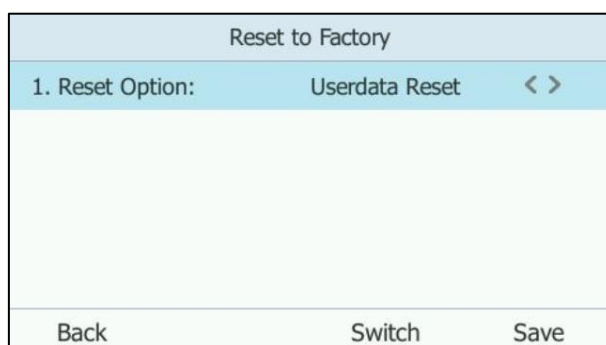

The LCD screen prompts the following warning:

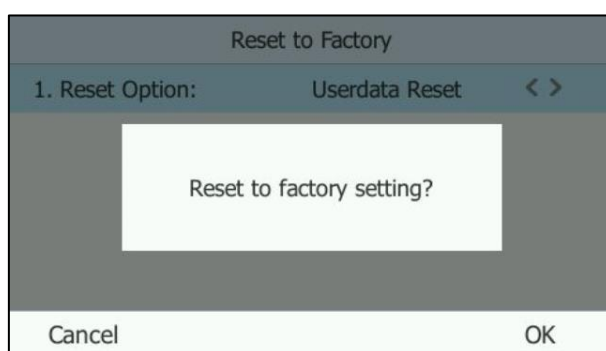

4. Press the **OK** soft key.

The LCD screen prompts "Welcome Initializing...Please wait".

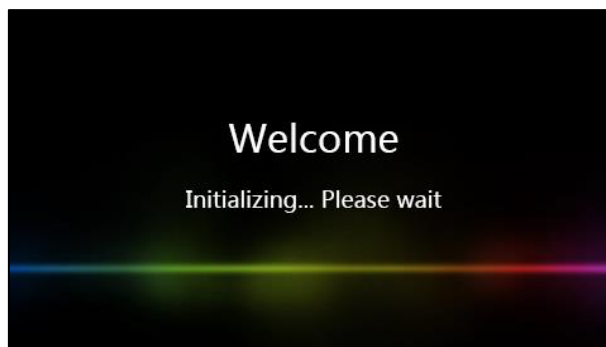

The phone will be reset to factory successfully after startup.

**Note**

You can also long press the  soft key to perform the full reset function when the phone is idle.

Reset of the phone may take a few minutes. Do not power off until the phone starts up successfully.



## Regulatory Notices

### Service Agreements

Contact your Yealink Authorized Reseller for information about service agreements applicable to your product.

### Limitations of Liability

TO THE FULL EXTENT ALLOWED BY LAW, YEALINK EXCLUDES FOR ITSELF AND ITS SUPPLIERS ANY LIABILITY, WHETHER BASED IN CONTRACT OR TORT (INCLUDING NEGLIGENCE), FOR INCIDENTAL, CONSEQUENTIAL, INDIRECT, SPECIAL, OR PUNITIVE DAMAGES OF ANY KIND, OR FOR LOSS OF REVENUE OR PROFITS, LOSS OF BUSINESS, LOSS OF INFORMATION OR DATA, OR OTHER FINANCIAL LOSS ARISING OUT OF OR IN CONNECTION WITH THE SALE, INSTALLATION, MAINTENANCE, USE, PERFORMANCE, FAILURE, OR INTERRUPTION OF ITS PRODUCTS, EVEN IF YEALINK OR ITS AUTHORIZED RESELLER HAS BEEN ADVISED OF THE POSSIBILITY OF SUCH DAMAGES, AND LIMITS ITS LIABILITY TO REPAIR, REPLACEMENT, OR REFUND OF THE PURCHASE PRICE PAID, AT YEALINK'S OPTION. THIS DISCLAIMER OF LIABILITY FOR DAMAGES WILL NOT BE AFFECTED IF ANY REMEDY PROVIDED HEREIN SHALL FAIL OF ITS ESSENTIAL PURPOSE.

### Safety Instructions

**Save these instructions. Read these safety instructions before use!**

The following basic safety precautions should always be followed to reduce risk of fire, electrical shock, and other personal injury.

#### General Requirements

- Before you install and use the device, read the safety instructions carefully and observe the situation during operation.
- During the process of storage, transportation, and operation, please always keep the device dry and clean.
- During the process of storage, transportation, and operation, please avoid collision and crash of the device.
- Please attempt not to dismantle the device by yourself. In case of any discrepancy, please contact the appointed maintenance center for repair.
- Without prior written consent, no organization or individual is permitted to make any change to the structure or the safety design of the device. Yealink is under no circumstance liable to consequences or legal issues caused by such changes.
- Please refer to the relevant laws and statutes while using the device. Legal rights of others should be respected as well.

#### Environmental Requirements

- Place the device at a well-ventilated place. Do not expose the device under direct sunlight.
- Keep the device dry and free of dusts.

- Place the device on a stable and level platform.
- Please place no heavy objects on the device in case of damage and deformation caused by the heavy load.
- Keep at least 10 cm between the device and the closest object for heat dissipation.
- Do not place the device on or near any inflammable or fire-vulnerable object, such as rubber-made materials.
- Keep the device away from any heat source or bare fire, such as a candle or an electric heater.
- Keep the device away from any household appliance with strong magnetic field or electromagnetic field, such as a microwave oven or a refrigerator.

### Operating Requirements

- Do not let a child operate the device without guidance.
- Do not let a child play with the device or any accessory in case of accidental swallowing.
- Please use the accessories provided or authorized by the manufacturer only.
- The power supply of the device shall meet the requirements of the input voltage of the device. Please use the provided surge protection power socket only.
- Before plugging or unplugging any cable, make sure that your hands are completely dry.
- Do not spill liquid of any kind on the product or use the equipment near water, for example, near a bathtub, washbowl, kitchen sink, wet basement or near a swimming pool.
- Do not tread on, pull, or over-bend any cable in case of malfunction of the device.
- During a thunderstorm, stop using the device and disconnect it from the power supply. Unplug the power plug and the Asymmetric Digital Subscriber Line (ADSL) twisted pair (the radio frequency cable) to avoid lightning strike.
- If the device is left unused for a rather long time, disconnect it from the power supply and unplug the power plug.
- When there is smoke emitted from the device, or some abnormal noise or smell, disconnect the device from the power supply, and unplug the power plug immediately. Contact the specified maintenance center for repair.
- Do not insert any object into equipment slots that is not part of the product or auxiliary product.
- Before connecting a cable, connect the grounding cable of the device first. Do not disconnect the grounding cable until you disconnect all other cables.

### Cleaning Requirements

- Before cleaning the device, stop using it and disconnect it from the power supply.
- Use a piece of soft, dry and anti-static cloth to clean the device.
- Keep the power plug clean and dry. Using a dirty or wet power plug may lead to electric shock or other perils.

## Appendix A - Time Zones

Time Zone	Time Zone Name
-11	Samoa
-10	United States-Hawaii-Aleutian, United States-Alaska-Aleutian
-9:30	French Polynesia
-9	United States-Alaska Time
-8	Canada(Vancouver,Whitehorse), Mexico(Tijuana,Mexicali), United States-Pacific Time
-7	Canada(Edmonton,Calgary), Mexico(Mazatlan,Chihuahua), United States-MST no DST, United States-Mountain Time
-6	Canada-Manitoba(Winnipeg), Chile(Easter Islands), Mexico(Mexico City,Acapulco), United States-Central Time
-5	Bahamas(Nassau), Canada(Montreal,Ottawa,Quebec), Cuba(Havana), United States-Eastern Time
-4:30	Venezuela(Caracas)
-4	Canada(Halifax,Saint John), Chile(Santiago), Paraguay(Asuncion), United Kingdom-Bermuda(Bermuda), United Kingdom(Falkland Islands), Trinidad&Tobago
-3:30	Canada-New Foundland(St.Johns)
-3	Argentina(Buenos Aires), Brazil(DST), Brazil(no DST), Denmark-Greenland(Nuuk)
-2:30	Newfoundland and Labrador
-2	Brazil(no DST)
-1	Portugal(Azores)
0	Denmark-Faroe Islands(Torshavn), GMT, Greenland, Ireland(Dublin), Morocco, Portugal(Lisboa,Porto,Funchal), Spain-Canary Islands(Las Palmas), United Kingdom(London)
+1	Albania(Tirane), Austria(Vienna), Belgium(Brussels), Caicos, Chad, Croatia(Zagreb), Czech Republic(Prague), Denmark(Kopenhagen), France(Paris), Germany(Berlin), Hungary(Budapest), Italy(Rome), Luxembourg(Luxembourg), Macedonia(Skopje), Namibia(Windhoek), Netherlands(Amsterdam), Spain(Madrid)
+2	Estonia(Tallinn), Finland(Helsinki), Gaza Strip(Gaza), Greece(Athens), Israel(Tel Aviv), Jordan(Amman), Latvia(Riga), Lebanon(Beirut), Moldova(Kishinev), Romania(Bucharest), Russia(Kaliningrad), Syria(Damascus), Turkey(Ankara), Ukraine(Kyiv, Odessa)
+3	East Africa Time, Iraq(Baghdad), Russia(Moscow)
+3:30	Iran(Teheran)
+4	Armenia(Yerevan), Azerbaijan(Baku), Georgia(Tbilisi), Kazakhstan(Aktau), Russia(Samara)
+4:30	Afghanistan(Kabul)
+5	Kazakhstan(Aqtobe), Kyrgyzstan(Bishkek), Pakistan(Islamabad), Russia(Chelyabinsk)
+5:30	India(Calcutta)
+5:45	Nepal(Katmandu)
+6	Kazakhstan(Astana, Almaty), Russia(Novosibirsk,Omsk)
+6:30	Myanmar(Naypyitaw)
+7	Russia(Krasnoyarsk), Thailand(Bangkok)
+8	Australia(Perth), China(Beijing), Russia(Irkutsk, Ulan-Ude), Singapore(Singapore)
+8:45	Eucla
+9	Japan(Tokyo), Korea(Seoul), Russia(Yakutsk,Chita)

<b>Time Zone</b>	<b>Time Zone Name</b>
+9:30	Australia(Adelaide), Australia(Darwin)
+10	Australia(Brisbane), Australia(Hobart), Australia(Sydney,Melbourne,Canberra), Russia(Vladivostok)
+10:30	Australia(Lord Howe Islands)
+11	New Caledonia(Noumea), Russia(Srednekolymsk Time)
+11:30	Norfolk Island
+12	New Zealand(Wellington,Auckland), Russia(Kamchatka Time)
+12:45	New Zealand(Chatham Islands)
+13	Tonga(Nukualofa)
+13:30	Chatham Islands
+14	Kiribati

# Index

## A

About This Guide [vi](#)  
 Account Lock [28](#)  
 Adding the Location Information [85](#)  
 Administrator Password [44](#)  
 Always Online [27](#)  
 Answering Calls [95](#)  
 Appendix A-Time Zone [211](#)  
 Assigning Skype for Business Contacts to the EXP40 [190](#)  
 Assigning/Removing Delegates [124](#)  
 Attended Transfer [137](#)  
 Audio Settings [48](#)  
 Auto Answer [97](#)

## B

Backlight [40](#)  
 Basic Network Settings [36](#)  
 Basic Call Features [93](#)  
 Better Together over Ethernet [171](#)  
 Blind Transfer [136](#)  
 Boss-Admin Feature [123](#)  
 Bluetooth [75](#)  
 Branch Office Resiliency [158](#)  
 BToE Sign-in [181](#)

## C

Calendar [100](#)  
 Call Forward [112](#)  
 Call History Management [71](#)  
 Call Hold/Resume [99](#)  
 Call Mute [99](#)  
 Call Park [152](#)  
 Call Transfer [136](#)  
 Call Waiting [97](#)  
 Changing Presence Status [25](#)  
 Contrast [41](#)  
 Common Area Phone [167](#)  
 Connecting the EXP40 [187](#)  
 Contact Management [50](#)  
 Customizing Your Phone [39](#)

## D

Declaration of Conformity [vi](#)  
 Device Pairing for Online [21](#)  
 Dial-now [87](#)  
 Documentations [9](#)  
 Dual Headset [74](#)

## E

E911 [75](#)  
 Emergency Call [86](#)  
 Ending Calls [96](#)

Entering Data and Editing Fields [32](#)  
 EXP40 Expansion [187](#)  
 EXP40 Hardware Component Instructions [189](#)

## G

General Settings [39](#)  
 Getting Started [11](#)  
 Getting Started with Better Together over Ethernet [171](#)  
 Group Call Pickup [138](#)

## H

Hardware Component Instructions [1](#)  
 Headset Mode Activation/Deactivation [73](#)  
 Headset Prior [73](#)  
 Headset Use [73](#)

## I

Icon Instructions [3](#)  
 Idle Screen [29](#)  
 In This Guide [vi](#)  
 Inbound Private Line [134](#)  
 Initiating a Conference Call [138](#)  
 Installing the Yealink Better Together over Ethernet [171](#)

## K

Key as Send [45](#)

## L

Language [39](#)  
 LED Instructions [4](#)  
 Limitations of Liability [209](#)  
 Live Dialpad [89](#)  
 Listening to the Voice Mail [154](#)  
 Local Directory [56](#)  
 Location Notification [83](#)

## M

Managing the Conference Participants [143](#)  
 Modifying the Privacy Mode from the Phone [90](#)  
 Modifying the Privacy Mode from the Skype for Business client [91](#)  
 Multicast Paging [158](#)

## P

- Packaging Contents 11
- Phone Initialization 17
- Phone Installation 14
- Phone Lock 46
- Phone Status 35
- PIN Sign in 20
- Placing Calls 93
- Placing Calls to Contacts 68
- Privacy Mode 90

## O

- Overview 1

## R

- Redialing Numbers 97
- Receiving RTP Stream 161
- Response Group 122
- Regulatory Notices 209
- Ring Tones 49

## S

- Safety Instructions 209
- Searching for Contacts 69
- Sending RTP Stream 159
- Setting up a Meeting in Outlook 102
- Setting up a Skype Conference in Outlook 101
- Setting up an Appointment in Outlook 101
- Setting up an Event in Outlook 102
- Service Agreements 209
- Sign-in 17
- Signing into a Common Area Phone 167
- Sign-out 21
- Signing out of a Common Area Phone 169
- Skype for Business Conference 138
- Skype for Business Directory 51
- Switching to Skype for Business Accounts 168

## T

- Table of Contents viii
- Time & Date 42
- Troubleshooting 187

## U

- User Interfaces 5
- User Sign In 19
- Using Better Together over Ethernet 184
- Using Multicast Paging 162
- Using the Calendar 104
- Using the Boss-Admin 127
- Using the EXP40 191
- Using the Common Area Phone 167

## V

- Volume 48
- Voice Mail 153
- Viewing the Bosses/Delegates 126
- Viewing the Conference Participants 141
- Viewing the Location Information 86

## W

- Web User Interface 7
- Working With Schedule Reminders 107